

OPERATOR'S MANUAL & SALES AND ENGINEERING DATA

INCLUDING: SPECIFICATIONS, SERVICE KITS, GENERAL INFORMATION, TROUBLESHOOTING.
 INCLUDE MANUALS: AF106X-XX Air Motor (pn 97999-1473), 66475-XXX Lower Pump End (pn 97999-111) &
 S-632 General Information Manual (pn 97999-624).

RELEASED: 2-10-10
 (REV. 01)

10" AIR MOTOR
45:1 RATIO
6" STROKE

AF1045BXXXXXX-XX-X TWO-BALL PUMP SERIES Carbon Steel



**READ THIS MANUAL CAREFULLY BEFORE INSTALLING,
 OPERATING OR SERVICING THIS EQUIPMENT.**

It is the responsibility of the employer to place this information in the hands of the operator. Keep for future reference.
 The original language of this manual is English.

SERVICE KITS

- Use only genuine ARO® replacement parts to assure compatible pressure rating and longest service life.
- **637489** for repair of air motor section.
- **637098-X43** for repair of lower pump end. Refer to the chart on page 2 for description of -X43 options.

SPECIFICATIONS

Model Series (refer to option chart)	AF1045BXXXXXX-XX-X
Pump Type	Air Operated, Two-Ball Double Acting Pump
Ratio	45:1
Air Motor	AF1060-XX
Motor Repair Kit	637489
Motor Diameter	10" (25.4 cm)
Stroke (double acting)	6" (15.2 cm)
Air Inlet (female)	3/4 - 14 NPTF - 1
Air Exhaust (female)	1-1/4 - 11-1/2 NPSM
Lower Pump End Series	66475-XXX
Lower Pump Repair Kit	637098-X43
Material Inlet (female)	2 - 11-1/2 NPTF - 1
Material Outlet (female)	1 - 11-1/2 NPTF - 1
Weight	132 lbs (59.9 kgs)

PUMP PERFORMANCE

Air Inlet Pressure Range	30 - 90 p.s.i.g. (2.1 - 6.2 bar)
Fluid Pressure Range	1350 - 4050 p.s.i.g. (93.1 - 279.3 bar)
Maximum Rec'd Cycles / Minute	70
Displacement In.³ Per Cycle	20.7
Volume / Cycle	11.5 oz. (339.1 ml)
Cycles Per Gallon	11.2
Flow @ 70 Cycles / Minute	6.27 g.p.m. (23.7 l.p.m.)
Noise Level @ 60 p.s.i. - 40 c.p.m.	89.8 db(A)*

* The pump sound pressure level has been updated to an Equivalent Continuous Sound Level (LAeq) to meet the intent of ANSI S1.13-1971, CAGI-PNEUROP S5.1 using four microphone locations.

PUMP DATA

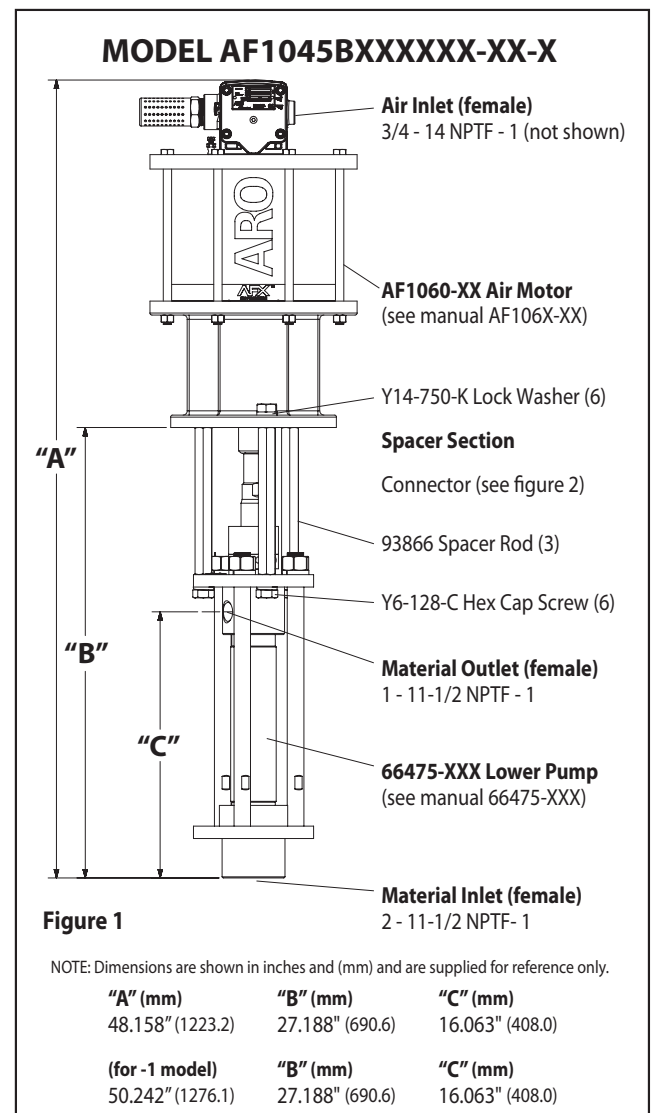

IMPORTANT

This is one of four documents which support the pump. Replacement copies of these forms are available upon request.

- AF1045BXXXXXX-XX-X** Model Operator's Manual (pn 97999-1523)
- S-632** General Information - Air / Hydraulic Operated Piston Pumps (pn 97999-624)
- 66475-XXX** Lower Pump End Operator's Manual (pn 97999-111)
- AF106X-XX** Air Motor Operator's Manual (pn 97999-1473)

GENERAL DESCRIPTION

The two-ball pumps are primarily designed for the high volume transfer of light and medium viscosity fluids compatible with carbon steel. The lower pump is designed for easy priming and the double acting feature is standard in all ARO industrial pumps. Material is delivered to the pump discharge outlet on both the up and down stroke.

The motor is connected to the lower pump end by a spacer section. This allows for lubrication of the upper packing gland and prevents motor contamination because of normal wear and eventual leakage through the material packing gland. Be sure the solvent cup is adequately filled with lubricant to protect the upper packings and insure longest service life.

⚠ WARNING HAZARDOUS PRESSURE. Do not exceed maximum operating pressure of 4050 p.s.i. (279.3 bar) at 90 p.s.i. (6.2 bar) inlet air pressure.

Pump Ratio X Inlet Pressure to Pump Motor	=	Maximum Pump Fluid Pressure
--	----------	--

Pump ratio is an expression of the relationship between the pump motor area and the lower pump end area. EXAMPLE: When 150 p.s.i. (10.3 bar) inlet pressure is supplied to the motor of a 4:1 ratio pump, it will develop a maximum of 600 p.s.i. (41.4 bar) fluid pressure (at no flow) - as the fluid control is opened, the flow rate will increase as the motor cycle rate increases to keep up with the demand.

⚠ WARNING Refer to general information sheet for additional safety precautions and important information.

NOTICE: Thermal expansion can occur when the fluid in the material lines is exposed to elevated temperatures. Example: Material lines located in a non-insulated roof area can warm due to sunlight. Install a pressure relief valve in the pumping system.

Replacement warning label (pn 92325) is available upon request.

TROUBLE SHOOTING

Pump problems can occur in either the air motor section or the lower pump end section. Use these basic guidelines to help determine which section is affected.

Pump will not cycle.

- Be certain to first check for non-pump problems including kinked, restrictive or plugged inlet / outlet hose or dispensing device. Depressurize the pump system and clean out any obstructions in the inlet / outlet material lines.
- Refer to the motor manual for trouble shooting if the pump does not cycle and / or air leaks from the air motor.
- Damaged motor. Service the motor.

Pump cycles but does not deliver material.

- Refer to the lower pump end manual for further trouble shooting.

PUMP CONNECTION - UPPER / LOWER

NOTE: All threads are right hand.

1. Lay the pump assembly on a work bench.
2. Remove the three (Y6-128-C) cap screws and (Y14-750-K) lock washers from the three spacer rods (see figure 1).
3. Pull the air motor from the lower pump end until the motor piston rod is in the "down" position and the lower pump end rod is in the "up" position.
4. Remove the three spacer rods by removing the three (Y6-128-C) cap screws and (Y14-750-K) lock washers.
5. Using e-ring pliers, slide the "e" ring up far enough to allow the sleeve to move upward and release the two connectors (see figure 2).

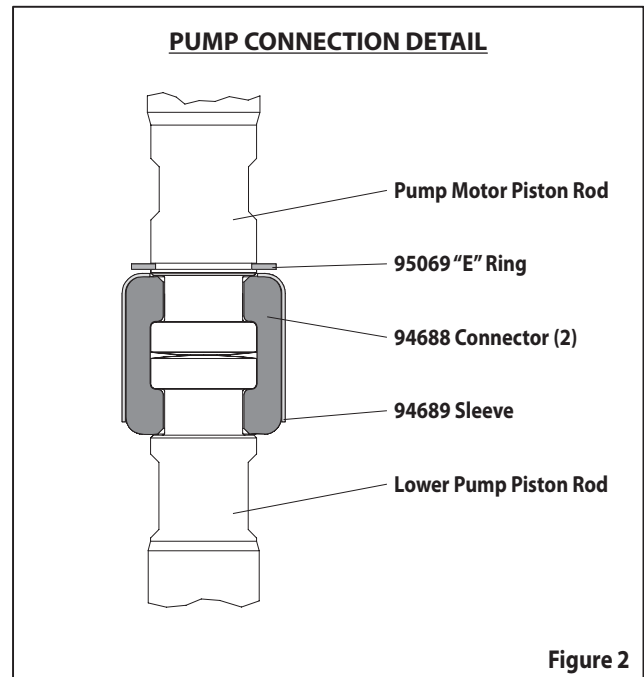

Figure 2

REASSEMBLY

1. Align the pump motor with the lower pump end. Position the air inlet of the motor 122° from the material outlet.
2. Install the two (94688) connectors and retain with the (94689) sleeve. Slide the (95069) "e" ring back into position.
3. Assemble the three (93866) spacer rods to the lower pump and secure using three (Y14-750-K) lock washers and (Y6-128-C) cap screws.
4. Reinstall the spacer rods to the pump motor.
5. Bring the motor and lower pump together and retain with three (Y14-750-K) lock washers and (Y6-128-C) cap screws.

PERFORMANCE CURVES

