

Blue-White Industries, Ltd.

FLEXFLO® Peristaltic Metering Pumps

Dimensions:

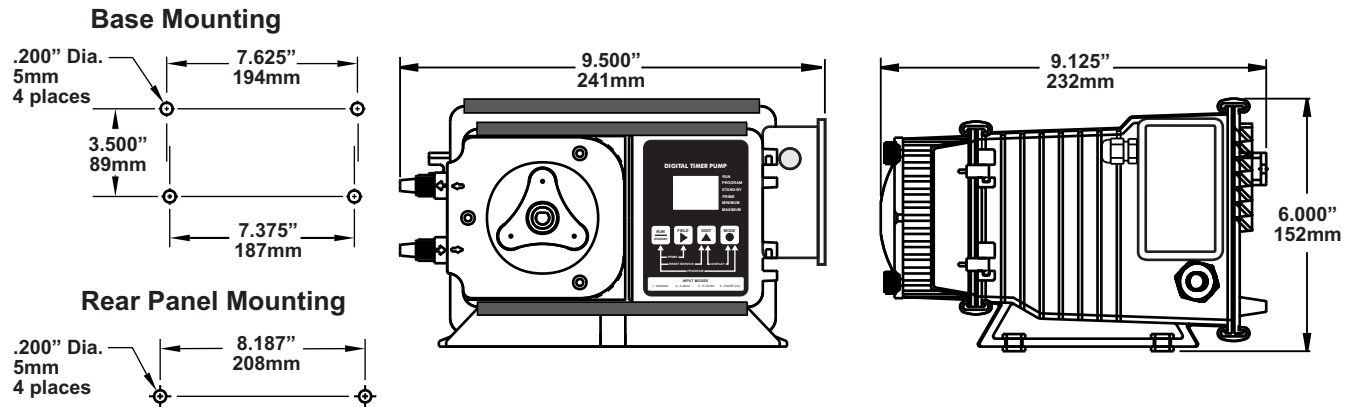

Model Number Matrix:

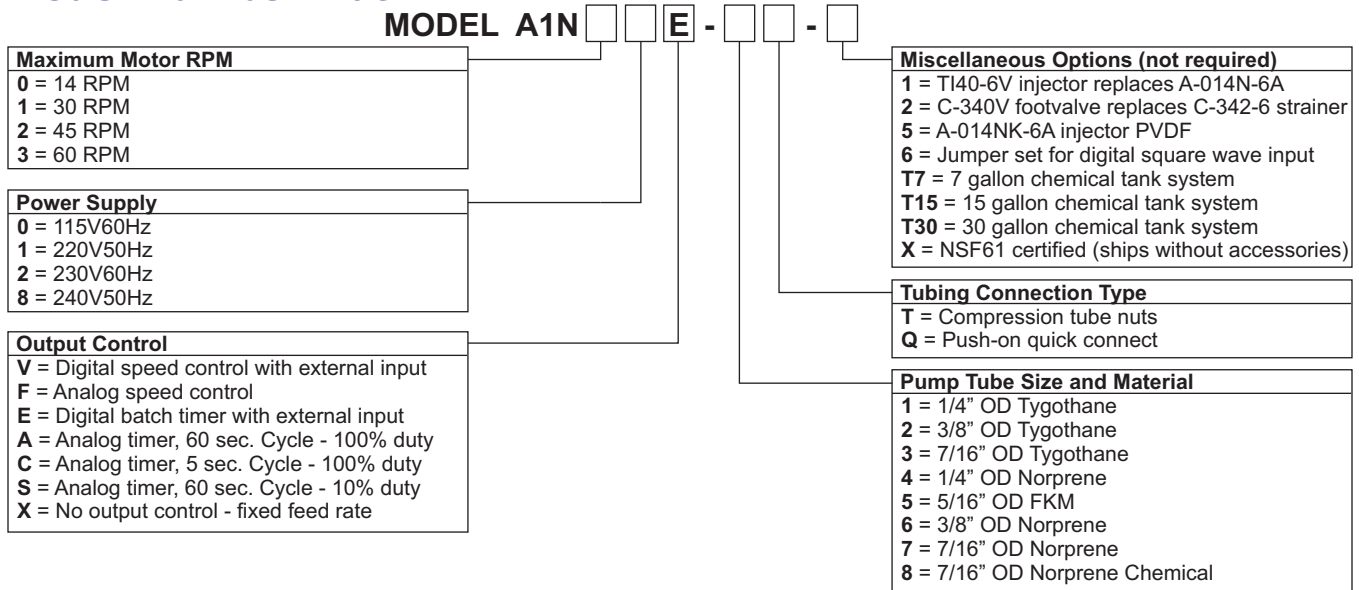

Maximum Flow rate and pressure capacities:

Tube no.	Tubing Material	14 RPM MODELS					30 RPM MODELS					45 RPM MODELS					60 RPM MODELS				
		ml/m	oz/m	lph	gph	PSI(bar)	ml/m	oz/m	lph	gph	PSI(bar)	ml/m	oz/m	lph	gph	PSI(bar)	ml/m	oz/m	lph	gph	PSI(bar)
1	Tygothane	15	0.51	0.90	0.24	65(4.5)	35	1.18	2.10	0.55	65(4.5)	54	1.83	3.24	0.86	65(4.5)	67	2.26	4.02	1.06	65(4.5)
2	Tygothane	32	1.08	1.92	0.51	65(4.5)	75	2.54	4.50	1.19	65(4.5)	115	3.89	6.90	1.82	65(4.5)	140	4.73	8.40	2.22	65(4.5)
3	Tygothane	73	2.47	4.37	1.16	50(3.5)	173	5.85	10.38	2.74	50(3.5)	261	8.82	15.66	4.14	50(3.5)	326	11.01	19.56	5.17	50(3.5)
4	Norprene	6	0.20	0.36	0.10	100(6.9)	13	0.44	0.78	0.21	100(6.9)	21	0.71	1.26	0.33	100(6.9)	25	0.85	1.50	0.40	75(5.2)
5	FKM	11	0.37	0.66	0.17	25(1.7)	26	0.88	1.56	0.41	25(1.7)	39	1.31	2.34	0.62	25(1.7)	48	1.62	2.88	0.76	25(1.7)
6	Norprene	18	0.61	1.08	0.29	100(6.9)	42	1.42	2.52	0.67	100(6.9)	63	2.13	3.78	1.00	100(6.9)	79	2.67	4.74	1.25	75(5.2)
7	Norprene	57	1.92	3.42	0.90	50(3.5)	138	4.66	8.28	2.19	50(3.5)	200	6.76	12.00	3.17	50(3.5)	250	8.45	15.00	3.96	50(3.5)
8	Nor Chem	40	1.35	2.40	0.63	50(3.5)	84	2.80	5.04	1.31	50(3.5)	140	4.73	8.40	2.22	50(3.5)	180	6.10	10.80	2.85	50(3.5)

Gallons shown are U.S. Gallons

Replacement Pump Tubes:

Pump Model Number Suffix	Pump Tube Part Number	Pump Tube Material	Nominal Pump Tube OD
-1T	A-002N-1T	Tygothane	1/4" (6,4mm)
-2T	A-002N-2T	Tygothane	3/8" (9,5mm)
-3T	A-002N-3T	Tygothane	7/16" (11,1mm)
-4T	A-002N-4T	Norprene	1/4" (6,4mm)
-5T	A-002N-5T	Viton	5/16" (7,9mm)
-6T	A-002N-6T	Norprene	3/8" (9,5mm)
-7T	A-002N-7T	Norprene	7/16" (11,1mm)
-8T	A-002N-8T	Norprene Chemical	7/16" (11,1mm)
-1Q	A-002N-1Q	Tygothane	1/4" (6,4mm)
-2Q	A-002N-2Q	Tygothane	3/8" (9,5mm)
-4Q	A-002N-4Q	Norprene	1/4" (6,4mm)
-6Q	A-002N-6Q	Norprene	3/8" (9,5mm)