



LIQUID METER TYPE FMC

INNOVATORS
IN FLOW TECHNOLOGY

THE FLUX LIQUID METER TYPE FMC NUTATING DISC TYPE



The technique: an advanced technology

For quality assurance, ecological and economic reasons, the requirement for safety and control in industry increases constantly. When it comes to liquids handling, industry is concerned with ensuring absolute safety combined with maximum measurement accuracy. The FLUX FMC liquid meter meets these concerns and criteria. Its versatility and operating simplicity make child's play of measuring operations.

The measuring function: a well-proven design

The flow of liquid through the measuring chamber causes the disc to nutate. This movement is converted into a rotary motion which is detected by a sensor unit. The pulses generated by this sensor are processed by the integrated micro-computer and shown on the liquid crystal display. A filter at the meter inlet prevents small particles from entering the measuring chamber. To achieve high measurement accuracy, the system must always be completely filled with liquid (liquid-filled-system).

In operation: adaptable to every application

Whether for portable use with barrel pumps or fixed installation into pipework systems, the FLUX FMC liquid meter provides high measurement accuracy and keeps the liquids under control. The FLUX FMC handles thin to medium viscosity liquids up to 2500 mPas (cP). The models FMC 100 are available in PP, ETFE and STAINLESS STEEL for flowrates of 10 – 100 l/min. All models FMC 100 are explosion-proof for use in hazardous locations. The models FMC 250 in PP and PVDF are designed especially for fixed installation into pipework systems and for flowrates of 25 - 250 l/min.

The control system: precise and safe

In conjunction with an interface amplifier, the FLUX FMC liquid meter can also be used as a presettable batch controller, actuating a magnetic valve and/or pump. Once the quantity has been set, a keystroke starts the metering operation. When the preset quantity has been measured, the interface amplifier disconnects the magnetic valve and/or pump motor.

Features and benefits:

- Simplified handling
- Easy-to-read 13 mm 7-digit liquid-crystal-display
- Display of quantity per operation, totalizer or instantaneous flowrate per minute
- Presettable batch controller up to 9999 litres per operation
- 10 presets for quantity
- Easy to calibrate
- 10 calibration constants for differing liquids
- Direct or remote control service
- Modular design – measuring unit, amplifier and digital display unit either integrated or separate
- explosion-proof according to Directive 94/9/EC – ATEX 100 – EC Type Examination Certificate No. PTB 03 ATEX 2014
- Protected to IP 54
- Display in litres, Imperial gallons, US gallons or kilograms
- quickly and easily mounted

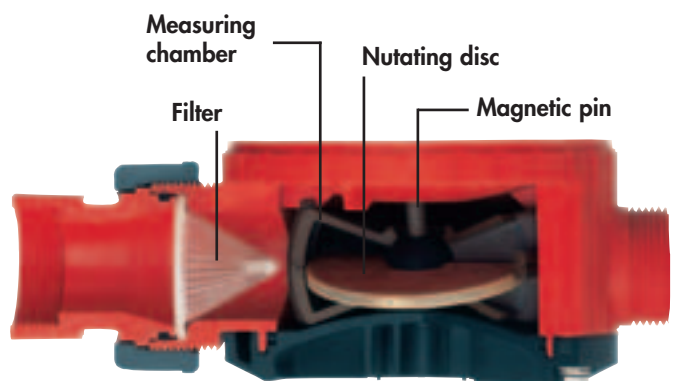



Example of type code of liquid meter FMC
FMC 100/PP/O/F
FMC 100/PP/O/F = Design
FMC 100/PP/O/F = Model
FMC 100/PP/O/F = Material meter body
FMC 100/PP/O/F = Material seal
FMC 100/PP/O/F = Version (F = use with barrel pump
A = fixed installation into pipework)

FMC 100/PP/. /F in Polypropylene for portable use with barrel pumps	4
FMC 100 PP/. /A in Polypropylene for fixed installation into pipework systems	5
FMC 100/ETFE/. /F in Ethylene-Tetrafluor-Ethylene for portable use with barrel pumps	6
FMC 100/ETFE/. /A in Ethylene-Tetrafluor-Ethylene for fixed installation into pipework systems	7
FMC 100/S/. /F in Stainless Steel (316 Ti) for portable use with barrel pumps	8
FMC 100/S/. /A in Stainless Steel (316 Ti) for fixed installation into pipework systems	9
FMC 250/PP/. /A in Polypropylene FMC 250/PVDF/. /A in Polyvinylidenfluoride for fixed installation into pipework systems	10
Examples of liquids Pressure loss charts	11
Interface amplifiers for preset batch control	12
Quick Action Taps with digital display unit	13
Examples of applications FMC 100	14
The Great Range of FLUX Pumps	15

FMC 100/PP/. /F IN POLYPROPYLENE FOR PORTABLE USE WITH BARREL PUMPS

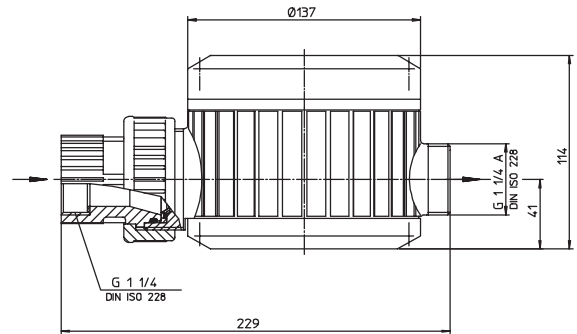

Type	FMC 100/PP/0/F	FMC 100/PP/1/F	FMC 100/PP/2/F
Flowrate	10 – 100 l/min	10 – 100 l/min	10 – 100 l/min
Operating pressure	max. 4 bar	max. 4 bar	max. 4 bar
Viscosity	max. 2500 mPas (cP)	max. 2500 mPas (cP)	max. 2500 mPas (cP)
Operating temperature	max. 60 °C	max. 60 °C	max. 60 °C
Accuracy	± 1%	± 1%	± 1%
Mode of operation	Normal mode or auto mode in conjunction with an interface amplifier		
Inlet-outlet connections	G 1 1/4 – 1 1/4 A BSP 1 1/4" female – BSP 1 1/4" male	G 1 1/4 – 1 1/4 A BSP 1 1/4" female – BSP 1 1/4" male	G 1 1/4 – 1 1/4 A BSP 1 1/4" female – BSP 1 1/4" male
Material: meter body	Polypropylene (PP)	Polypropylene (PP)	Polypropylene (PP)
Material: measuring chamber	PPS	PPS	PPS
Material: seal	EPDM (0)	FKM (1)	FEP (2)
Weight	1,1 kg	1,1 kg	1,1 kg
Part No.	A04 00 005	A04 00 007	A04 00 009

VERSION WITHOUT DIGITAL DISPLAY UNIT FOR USE WITH QUICK ACTION TAP – SEE PAGE 13

Liquid meter with top cover and connecting cable, 5 m long.
Part No. of quick action tap on page 13.

Part No.	A04 00 035	A04 00 037	A04 00 039
----------	------------	------------	------------

ACCESSORY FOR ALL MODELS FMC



Protective boot for display unit against impurities
and corrosive vapours

Part No. 001 42 017

FMC 100/PP/. /A IN POLYPROPYLENE FOR FIXED INSTALLATION INTO PIPEWORK

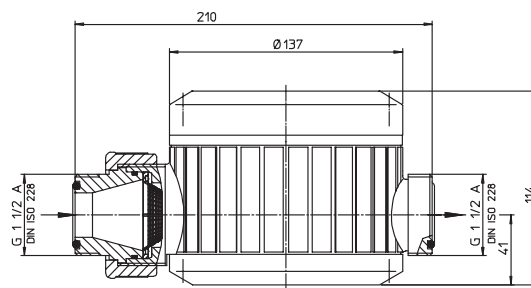

Type	FMC 100/PP/0/A	FMC 100/PP/1/A	FMC 100/PP/2/A
Flowrate	10 – 100 l/min	10 – 100 l/min	10 – 100 l/min
Operating pressure	max. 4 bar	max. 4 bar	max. 4 bar
Viscosity	max. 2500 mPas (cP)	max. 2500 mPas (cP)	max. 2500 mPas (cP)
Operating temperature	max. 60 °C	max. 60 °C	max. 60 °C
Genauigkeit	± 1%	± 1%	± 1%
Accuracy	Normal mode or auto mode in conjunction with an interface amplifier		
Inlet-outlet connections	G 1 1/2 A – G 1 1/2 A BSP 1 1/2" – BSP 1 1/2" male	G 1 1/2 A – G 1 1/2 A BSP 1 1/2" – BSP 1 1/2" male	G 1 1/2 A – G 1 1/2 A BSP 1 1/2" – BSP 1 1/2" male
Material: meter body	Polypropylene (PP)	Polypropylene (PP)	Polypropylene (PP)
Material: measuring chamber	PPS	PPS	PPS
Material: seal	EPDM (0)	FKM (1)	FEP (2)
Weight	1,1 kg	1,1 kg	1,1 kg
Part No.	A04 00 012	A04 00 014	A04 00 016

VERSION FOR USE WITH EXTERNAL DIGITAL DISPLAY UNIT

Liquid meter with top cover and connecting cable, 5 m long.

Part No.	A04 00 041	A04 00 043	A04 00 045
----------	------------	------------	------------

External digital display unit / Part No.

for wall mounting	001 42 008	for mounting into a switchboard	001 42 009
-------------------	-------------------	---------------------------------	-------------------

ACCESSORIES

Part No.			
Pipe connection DN 25 (PP)	001 41 947	001 41 947	001 41 947
Flange DN 25 (PP)	001 41 907	001 41 909	001 41 911
Flange DN 32 (PP)	001 41 913	001 41 915	001 41 917

FMC 100/ETFE/. /F IN ETHYLEN-TETRAFLUOR-ETHYLENE FOR PORTABLE USE WITH BARREL PUMPS

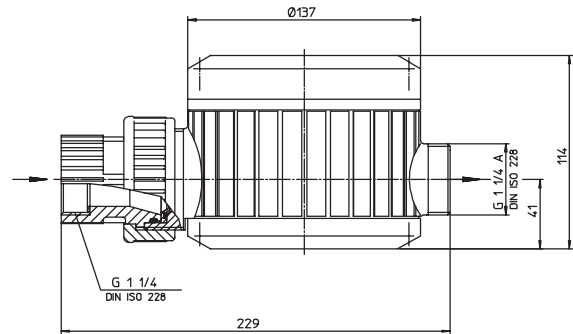

Type	FMC 100/ETFE/0/F	FMC 100/ETFE/1/F	FMC 100/ETFE/3/F
Flowrate	10 – 100 l/min	10 – 100 l/min	10 – 100 l/min
Operating pressure	max. 4 bar	max. 4 bar	max. 4 bar
Viscosity	max. 2500 mPas (cP)	max. 2500 mPas (cP)	max. 2500 mPas (cP)
Operating temperature	max. 60 °C	max. 60 °C	max. 60 °C
Accuracy	± 1%	± 1%	± 1%
Mode of operation	Normal mode or auto mode in conjunction with an interface amplifier		
Inlet-outlet connections	G 1 1/4 – G 1 1/4 A BSP 1 1/4" female – BSP 1 1/4" male	G 1 1/4 – G 1 1/4 A BSP 1 1/4" female – BSP 1 1/4" male	G 1 1/4 – G 1 1/4 A BSP 1 1/4" female – BSP 1 1/4" male
Material: meter body	Ethylen-Tetrafluor-Ethylene (ETFE)	Ethylen-Tetrafluor-Ethylene (ETFE)	Ethylen-Tetrafluor-Ethylene (ETFE)
Material: measuring chamber	Ethylen-Tetrafluor-Ethylene (ETFE)	Ethylen-Tetrafluor-Ethylene (ETFE)	Ethylen-Tetrafluor-Ethylene (ETFE)
Material: seal	EPDM (0)	FKM (1)	FFKM (3)
Weight	1,4 kg	1,4 kg	1,4 kg
Part No.	A04 00 006	A04 00 008	A04 00 077

VERSION WITHOUT DIGITAL UNIT FOR USE WITH QUICK ACTION TAP – SEE PAGE 13

Liquid meter with top cover and connecting cable, 5 m long.
Part No. of quick action tap on page 13.

Part No.	A04 00 036	A04 00 038	A04 00 079
-----------------	-------------------	-------------------	-------------------

FMC 100/ETFE/. /A IN ETHYLEN-TETRAFLUOR-ETHYLENE FOR FIXED INSTALLATION INTO PIPEWORK

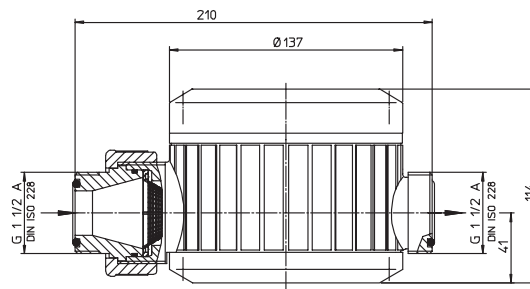

Type	FMC 100/ETFE/0/A	FMC 100/ETFE/1/A	FMC 100/ETFE/3/A
Flowrate	10 – 100 l/min	10 – 100 l/min	10 – 100 l/min
Operating pressure	max. 4 bar	max. 4 bar	max. 4 bar
Viscosity	max. 2500 mPas (cP)	max. 2500 mPas (cP)	max. 2500 mPas (cP)
Operating temperature	max. 60 °C	max. 60 °C	max. 60 °C
Accuracy	± 1%	± 1%	± 1%
Mode of operation	Normal mode or auto mode in conjunction with an interface amplifier		
Inlet-outlet connections	G 1 1/2 A – G 1 1/2 A BSP 1 1/2" – BSP 1 1/2" male	G 1 1/2 A – G 1 1/2 A BSP 1 1/2" – BSP 1 1/2" male	G 1 1/2 A – G 1 1/2 A BSP 1 1/2" – BSP 1 1/2" male
Material: meter body	Ethylen-Tetrafluor-Ethylene (ETFE)	Ethylen-Tetrafluor-Ethylene (ETFE)	Ethylen-Tetrafluor-Ethylene (ETFE)
Material: measuring chamber	Ethylen-Tetrafluor-Ethylene (ETFE)	Ethylen-Tetrafluor-Ethylene (ETFE)	Ethylen-Tetrafluor-Ethylene (ETFE)
Material: seal	EPDM (0)	FKM (1)	FFKM (3)
Weight	1,1 kg	1,1 kg	1,1 kg
Part No.	A04 00 013	A04 00 015	A04 00 078

VERSION FOR USE WITH EXTERNAL DIGITAL DISPLAY UNIT

Liquid meter with top cover and connecting cable, 5 m long.

Part No.	A04 00 042	A04 00 044	A04 00 080
----------	------------	------------	------------

External digital display unit / Part No.

for wall mounting	001 42 008	for mounting into a switchboard	001 42 009
-------------------	-------------------	---------------------------------	-------------------

ACCESSORIES

Part No.			
Pipe connection DN 25 (PVDF/ETFE)	001 41 948	001 41 948	001 41 948
Flange DN 25 (PVDF)	001 41 908	001 41 910	001 41 912
Flange DN 32 (PVDF)	001 41 914	001 41 916	001 41 918

FMC 100/S/. /F IN STAINLESS STEEL FOR PORTABEL USE WITH BARREL PUMPS

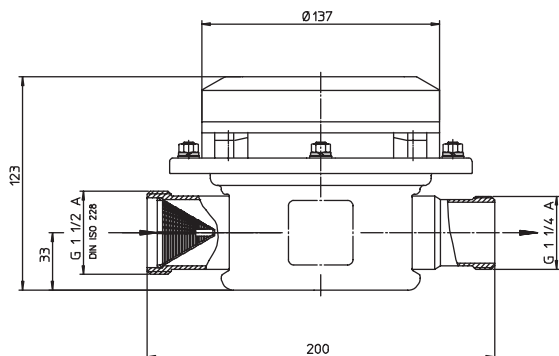

Type	FMC 100/S/0/F	FMC 100/S/1/F	FMC 100/S/2/F
Flowrate	10 – 100 l/min	10 – 100 l/min	10 – 100 l/min
Operating pressure	max. 6 bar	max. 6 bar	max. 6 bar
Viscosity	max. 2500 mPas (cP)	max. 2500 mPas (cP)	max. 2500 mPas (cP)
Operating temperature	max. 80 °C	max. 80 °C	max. 80 °C
Accuracy	± 1%	± 1%	± 1%
Mode of operation	Normal mode or auto mode in conjunction with an interface amplifier		
Inlet-outlet connections	G 1 1/2 A – G 1 1/4 A BSP 1 1/2" – BSP 1 1/4" male connecting piece to barrel pump NOT included in the FMC	G 1 1/2 A – G 1 1/4 A BSP 1 1/2" – BSP 1 1/4" male	G 1 1/2 A – G 1 1/4 A BSP 1 1/2" – BSP 1 1/4" male
Material: meter body	Stainless steel 316 Ti (S)	Stainless steel 316 Ti (S)	Stainless steel 316 Ti (S)
Material: measuring chamber	PPS	PPS	PPS
Material: seal	EPDM (0)	FKM (1)	FEP (2)
Weight	1,7 kg	1,7 kg	1,7 kg
Part No.	A04 00 029	A04 00 031	A04 00 033

VERSION WITHOUT DIGITAL DISPLAY UNIT FOR USE WITH QUICK ACTION TAP – SEE PAGE 13

Liquid meter with top cover and connecting cable, 5 m long.
Part No. of quick action tap on page 13.

Part No.	A04 00 053	A04 00 055	A04 00 057
----------	------------	------------	------------

ACCESSORIES

Part No.	A04 00 053	A04 00 055	A04 00 057
Connecting piece to barrel pump G 1 1/4 – G 1 1/2	959 06 059	959 06 059	959 06 059

FMC 100/S/.A IN STAINLESS STEEL FOR FIXED INSTALLATION INTO PIPEWORK

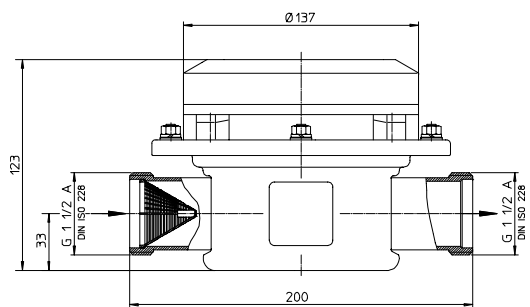

Connection G 1 1/2 A (BSP 1 1/2" male)

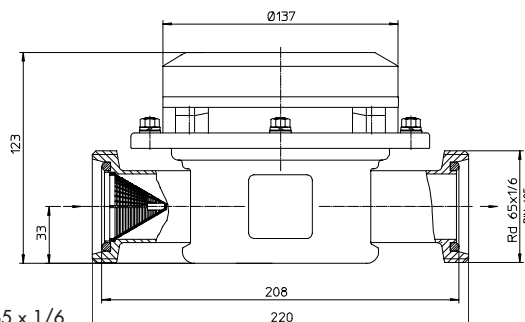

Connection Rd 65 x 1/6

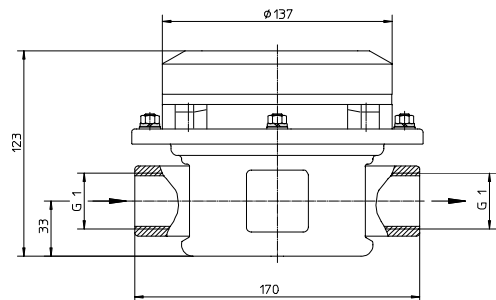

Connection G 1 (BSP 1" female)

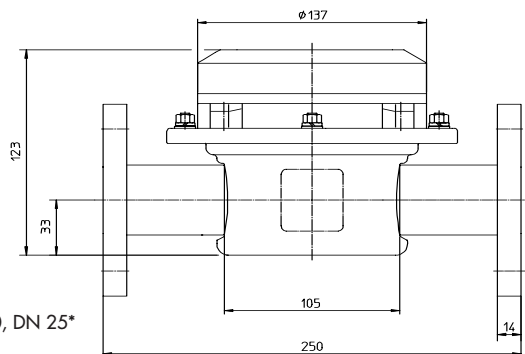

Connection PN 10, DN 25*

Type	FMC 100/S/0/A	FMC 100/S/1/A	FMC 100/S/2/A
Flowrate	10 – 100 l/min	10 – 100 l/min	10 – 100 l/min
Operating pressure	max. 6 bar	max. 6 bar	max. 6 bar
Viscosity	max. 2500 mPas (cP)	max. 2500 mPas (cP)	max. 2500 mPas (cP)
Operating temperature	max. 80 °C	max. 80 °C	max. 80 °C
Accuracy	± 1%	± 1%	± 1%
Mode of operation	Normal mode or auto mode in conjunction with an interface amplifier		
Inlet-outlet connections	see dimensional drawings above		
Material: meter body	Stainless steel316 Ti (S)	Stainless steel316 Ti (S)	Stainless steel316 Ti (S)
Material: measuring chamber	PPS	PPS	PPS
Material: seal	EPDM (0)	FKM (1)	FEP (2)
Weight	1,7 kg	1,7 kg	1,7 kg
Part No.			
Connection G 1 1/2 A	A04 00 071	A04 00 072	A04 00 073
Connection Rd 65 x 1/6	A04 00 023	A04 00 025	A04 00 027
Connection G 1	A04 00 085	A04 00 086	A04 00 087
Flange PN 10, DN 25*	A04 00 082	A04 00 083	A04 00 084

* Flange size: outer-Ø 115 mm, pitch circle-Ø 85 mm, 4 bores Ø 14 mm each

VERSION FOR USE WITH EXTERNAL DIGITAL DISPLAY UNIT

Liquid meter with top cover and connecting cable, 5 m long.

Part No.			
Connection G 1 1/2 A	A04 00 074	A04 00 075	A04 00 076
Connection Rd 65 x 1/6	A04 00 059	A04 00 061	A04 00 063

External digital display unit / Part No.

for wall mounting	001 42 008	for mounting into a switchboard	001 42 009
-------------------	-------------------	---------------------------------	-------------------

ACCESSORIES

Part No.			
Pipe connection RV32-40/25	001 41 986	001 41 987	001 41 988
Pipe connection RV32-40/32	001 41 989	001 41 990	001 41 991

FMC 250/PP/. /A, FMC 250/PVDF/. /A FOR FIXED INSTALLATION INTO PIPEWORK

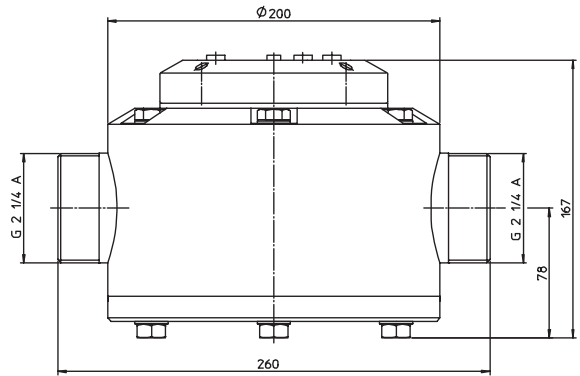

Type	FMC 250/PP/0/A	FMC 250/PP/1/A	FMC 250/PVDF/0/A	FMC 250/PVDF/1/A
Flowrate	25 – 250 l/min	25 – 250 l/min	25 – 250 l/min	25 – 250 l/min
Operating pressure	max. 6 bar	max. 6 bar	max. 6 bar	max. 6 bar
Viscosity	max. 2500 mPas (cP)	max. 2500 mPas (cP)	max. 2500 mPas (cP)	max. 2500 mPas (cP)
Operating temperature	max. 60 °C	max. 60 °C	max. 60 °C	max. 60 °C
Accuracy	± 1%	± 1%	± 1%	± 1%
Mode of operation	Normal mode or auto mode in conjunction with interface amplifier Type FSV 100			
Inlet-outlet connections*	G 2 1/4 A (BSP 2 1/4" male)	G 2 1/4 A (BSP 2 1/4" male)	G 2 1/4 A (BSP 2 1/4" male)	G 2 1/4 A (BSP 2 1/4" male)
Material: meter body	Polypropylene (PP)	Polypropylene (PP)	Polyvinylidenfluoride (PVDF)	Polyvinylidenfluoride (PVDF)
Material: measuring chamber	Polyethylene (PE)	Polyethylene (PE)	Polyvinylidenfluoride (PVDF)	Polyvinylidenfluoride (PVDF)
Material: seal	EPDM (0)	FKM (1)	EPDM (0)	FKM (1)
Weight	4,2 kg	4,2 kg	4,2 kg	4,2 kg
Part No.	A04 25 400	A04 25 410	A04 25 600	A04 25 610

* other connections on request

EXAMPLE OF APPLICATION



The FLUX FMC 250 for fixed installation into pipework systems

Material	Polypropylene (PP)	Ethylene-Tetrafluor-Ethylene (ETFE)	Polyvinyliden-fluoride (PVDF)	Stainless steel 316 Ti (S)
The examples are based on a temperature of 20 °C. Factors such as higher temperatures, different concentrations, impurities and mixtures of liquids have to be taken into account. For further information please see FLUX Resistance Chart.	Accumulator acid* Acetic acid Ammonia water Arsenic acid* Boric acid* Brake fluid Calcium chloride* Caustic soda Citric acid* Ferric chloride* Formic acid Glycol* Hydrochloric acid* Mineral oil* Phosphoric acid* Photo developer* Sulfuric acid up to 60%* Tartaric acid* Zinc chloride*	Bromine acid Butylamine Chloroforme** Diethylamine Essential oils** Ethyl acetate Ethylene oxide* Hydrofluoric acid up to 40%* Hydrogene peroxide* Nicotinic acid** Nitrating acid up to 70%** Nitric acid (concentrated)** Petroleum ether* Sulfuric acid up to 98%* Tetrahydrofurane**	Chloric acid Chromic acid Hydrobromic acid Hydrofluoric acid* Hydrogene peroxide* Nitric acid up to 75% Paraffine emulsion* Potassium bromide Sodium hypochlorite Sulfuric acid up to 98% Trichlorobenzene as well as most liquids listed under PP	Acetone Butanone Ether Ethyl alcohol Freon/Frigen** Glycerine Hexanol Isopropyl ether** Linseed oil* Methanol Methylene chloride* Methoxybutanol Mineral oil* Perchloroethylene* Petroleum* Styrene** Trichloroethylene** Vinegar

Material of seal:

- 0 = EPDM (Ethylene-Propylene-Diene-Rubber)
- *1 = FKM (Fluor-Rubber)
- **2 = FEP (Tetrafluorethylene-Perfluorpropylene)
- **3 = FFKM (Per-Fluor-Rubber)

PRESSURE LOSS CHARTS

TYPE FMC 100

Values with water at 20 °C
Tolerance ± 5%

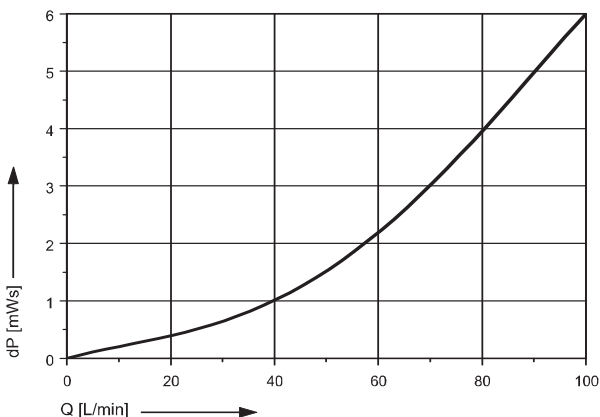

TYPE FMC 250

Values with water at 20 °C
Tolerance ± 5%

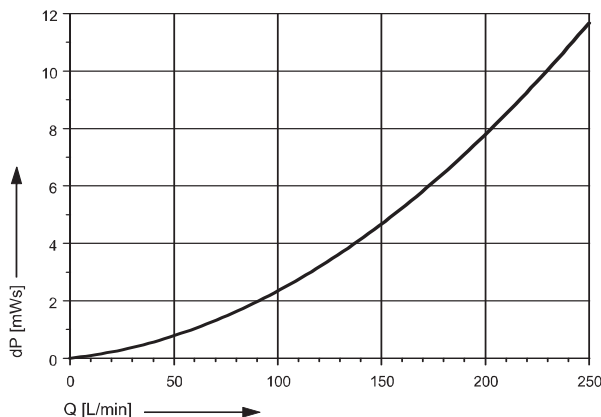

INTERFACE AMPLIFIER FOR PRE-SET BATCH CONTROL WITH FLUX FMC LIQUID METER IN AUTO MODE



Type FSV 100	Type FSV 112	Type FSV 132
integral mounting onto FMC – see picture on page 3. Supply voltage 230 Volt, 50 Hz, protected to IP 54. With 5 m power supply cable. Two output signals for: main flow control for a pump and/or magnetic valve and secondary control for turn down controlling a magnetic valve or relay. With plug connections for control features.	Complete with housing for wall mounting. Supply voltage 230 Volt, 50 Hz, protected to IP 54. Two output signals for: main flow control for a pump and/or magnetic valve and secondary control for turn down controlling a magnetic valve or relay. Input socket for power supply and output plugs for control features.	without housing for mounting into a switch-board. Supply voltage 230 Volt, 50 Hz, protected to IP 20. Two output signals for control of a pump and two magnetic valves.
Part No. 001 49 040	Part No. 001 49 041	Part No. 940 04 020



Accessories for FSV 100, FSV 112 and FSV 132	
1	Power supply cable, 5 m, for use with FSV 112 Part No. 934 08 037
2	Connecting cable to motor, 0,5 m, for use with FSV 100 and FSV 112 Part No. 934 08 035
3	Verbindungskabel Magnetventil, 5 m lang, für FSV 100 und FSV 112 Part No. 934 08 036
4	Connecting cable 5 m, to transmit the pulses from FMC to FSV 112 Part No. 934 08 039
5	Connecting cable, to transmit the pulses from FMC to FSV 121-1 Ex and FSV 132. Part No. 934 08 038 5 m long
	Part No. 934 08 040 10 m long

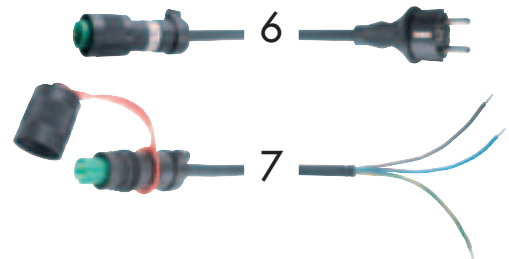





Type FSV 121-1 Ex	Type FSV 121 Ex	Accessories for FSV 121 Ex
explosion-proof to II 2 G EEx ed (ia) IIC T6. Supply voltage 230 Volt, 50 Hz, protected to IP 54. One output signal for control of a pump or a magnetic valve. Without plug connections. Connecting cable to transmit the pulses from FMC see above accessories item 5.	explosion-proof to II 2 G EEx ed (ia) IIC T6. Supply voltage 230 Volt, 50 Hz, protected to IP 54. One output signal for control of a pump or a magnetic valve. With connecting 5 m connecting cable to transmit the pulses from FMC. Input socket for power supply and output plugs for control features.	6 Power supply cable, 5 m Part No. 934 08 048
Part No. 001 49 039	Part No. 001 49 051	7 Connecting cable to motor or magnetic valve, 5 m Part No. 934 08 049

QUICK ACTION TAP COMPLETE WITH ELECTRONIC DIGITAL DISPLAY UNIT FOR USE WITH FMC 100 WITH TOP COVER



FMC 100/PP with top cover

Type	Quick Action Tap PP	Quick Action Tap PVDF
		
Flowrate	max. 50 l/min	max. 50 l/min
Operating pressure	max. 3 bar	max. 3 bar
Viscosity	max. 900 mPas (cP)	max. 900 mPas (cP)
Operating temperature	max. 50 °C	max. 50 °C
Inlet connection	DN 19	DN 19
Outlet tube	Ø 22 mm	Ø 22 mm
Material	Polypropylene (PP)	Polyvinylidenfluoride (PVDF)
Seal	FKM	FKM
Weight	0,5 kg	0,6 kg
Part No.	001 12 390	001 12 391

Type	Quick Action Tap MS	Quick Action Tap S
		
Flowrate	max. 80 l/min	max. 65 l/min
Operating pressure	max. 4 bar	max. 4 bar
Viscosity	max. 900 mPas (cP)	max. 900 mPas (cP)
Operating temperature	max. 80 °C	max. 80 °C
Inlet connection	Ø 32 mm	Ø 32 mm
Outlet tube	Ø 25 mm*	Ø 28 mm*
Material	Brass, nickel-plated (MS)	Stainless Steel 316 Ti (S)
Seal	PTFE	PTFE/FEP
Weight	1,5 kg	1,6 kg
Part No.	001 12 364	001 12 292

* Longer outlet tube Ø 20 mm for use with fume cone on request

EXAMPLES OF APPLICATIONS FLUX LIQUID METER TYPE FMC 100



Portable use:
FLUX FMC 100 with barrel pump



Auto mode: FLUX FMC 100 in conjunction with
interface amplifier Type FSV 100 as a presettable
batch controller actuating a barrel pump



Fixed installation into pipework systems:
FLUX FMC 100 with pipe or flange connections



Use with quick action tap:
FLUX FMC 100 with top cover
in conjunction with quick action
tap complete with electronic
digital display unit



YES!

I am interested in top class pump technology.
Please send the following catalogues:

- | | |
|---|--|
| <input type="checkbox"/> FLUX JUNIORFLUX | <input type="checkbox"/> FLUX CENTRIFUGAL IMMERSION PUMPS |
| <input type="checkbox"/> FLUX BARREL AND CONTAINER PUMPS | <input type="checkbox"/> FLUX AIR-OPERATED DIAPHRAGM PUMPS |
| <input type="checkbox"/> FLUX PUMP KITS | <input type="checkbox"/> FLUX LIQUID METERS FMO |
| <input type="checkbox"/> FLUX HIGH VISCOSITY LIQUID PUMPS | <input type="checkbox"/> FLUX PROCESS CONTROL SYSTEM PCS |

Mr / Mrs

Company

Address

Telephone

Fax

e-mail

Please mark with a cross, complete the address and then sent us a fax. Fax number see on the back side!



INNOVATORS IN FLOW TECHNOLOGY

All around the globe, FLUX is synonymous with top standards in pump technology. Whether it is barrel pumps, high viscosity liquid pumps, vertical centrifugal immersion pumps, air-operated diaphragm pumps, liquid meters, mixers or top class accessories – FLUX with its complete and comprehensive range is always the one to address to. Benefit from our competence. We look forward to hearing from you!

FLUX-GERÄTE GMBH
Talweg 12 · D-75433 Maulbronn
Tel. 070 43/101-0 · Fax 070 43/101-444
Fax International +49 70 43 / 1 01 -555
info@flux-pumpen.de · www.flux-pumpen.com