

# DMH 28X

Dosing pump

Installation and operating instructions



## Declaration of conformity

### GB: EC declaration of conformity

We, Grundfos, declare under our sole responsibility that the products DMH 280, DMH 281, DMH 283, DMH 285, DMH 286, DMH 287 and DMH 288, to which this declaration relates, are in conformity with these Council directives on the approximation of the laws of the EC member states:

- Machinery Directive (2006/42/EC).  
Standards used: EN 809:1998+A1:2009,  
EN ISO 12100-1+A1:2009,  
EN ISO 12100-2+A1:2009.
  - Low Voltage Directive (2006/95/EC).  
Standard used: EN 61010-1:2001 (second edition).
  - EMC Directive (2004/108/EC).\*
- \* Only for products with control variant AR or AT.

This EC declaration of conformity is only valid when published as part of the Grundfos installation and operating instructions.

### DE: EG-Konformitätserklärung

Wir, Grundfos, erklären in alleiniger Verantwortung, dass die Produkte DMH 280, DMH 281, DMH 283, DMH 285, DMH 286, DMH 287 und DMH 288, auf die sich diese Erklärung bezieht, mit den folgenden Richtlinien des Rates zur Angleichung der Rechtsvorschriften der EU-Mitgliedsstaaten übereinstimmen:

- Maschinenrichtlinie (2006/42/EG).  
Normen, die verwendet wurden: EN 809:1998+A1:2009,  
EN ISO 12100-1+A1:2009,  
EN ISO 12100-2+A1:2009.
  - Niederspannungsrichtlinie (2006/95/EG).  
Norm, die verwendet wurde: EN 61010-1:2001 (zweite Ausgabe).
  - EMV-Richtlinie (2004/108/EG).\*
- \* Nur für Produkte mit Steuerungsvariante AR oder AT.

Diese EG-Konformitätserklärung gilt nur, wenn sie in Verbindung mit der Grundfos Montage- und Betriebsanleitung veröffentlicht wird.

### ES: Declaración CE de conformidad

Nosotros, Grundfos, declaramos bajo nuestra entera responsabilidad que los productos DMH 280, DMH 281, DMH 283, DMH 285, DMH 286, DMH 287 y DMH 288, a los cuales se refiere esta declaración, están conformes con las Directivas del Consejo en la aproximación de las leyes de los Estados Miembros del EM:

- Directiva de Maquinaria (2006/42/CE).  
Normas aplicadas: EN 809:1998+A1:2009,  
EN ISO 12100-1+A1:2009,  
EN ISO 12100-2+A1:2009.
  - Directiva de Baja Tensión (2006/95/CE).  
Norma aplicada: EN 61010-1:2001 (segunda edición).
  - Directiva EMC (2004/108/CE).\*
- \* Solo para productos con variante de control AR o AT.

Esta declaración CE de conformidad sólo es válida cuando se publique como parte de las instrucciones de instalación y funcionamiento de Grundfos.

### HR: EZ izjava o usklađenosti

Mi, Grundfos, izjavljujemo pod vlastitom odgovornošću da je proizvod DMH 280, DMH 281, DMH 283, DMH 285, DMH 286, DMH 287 i DMH 288, na koji se ova izjava odnosi, u skladu s direktivama ovog Vijeća o usklađivanju zakona država članica EU:

- Direktiva za strojeve (2006/42/EZ).  
Korištene norme: EN 809:1998+A1:2009,  
EN ISO 12100-1+A1:2009,  
EN ISO 12100-2+A1:2009.
  - Direktiva za niski napon (2006/95/EZ).  
Korištena norma: EN 61010-1:2001 (drugo izdanje).
  - Direktiva za elektromagnetsku kompatibilnost (2004/108/EZ).\*
- \* Samo za proizvode s vrstom upravljanja AR ili AT.

Ova EZ izjava o sukladnosti važeća je jedino kada je izdana kao dio Grundfos montažnih i pogonskih uputa.

### CZ: ES prohlášení o shodě

My firma Grundfos prohlašujeme na svou plnou odpovědnost, že výrobky DMH 280, DMH 281, DMH 283, DMH 285, DMH 286, DMH 287 a DMH 288, na něž se toto prohlášení vztahuje, jsou v souladu s ustanoveními směrnice Rady pro sblížení právních předpisů členských států Evropského společenství v oblastech:

- Směrnice pro strojní zařízení (2006/42/ES).  
Použité normy: EN 809:1998+A1:2009,  
EN ISO 12100-1+A1:2009,  
EN ISO 12100-2+A1:2009.
  - Směrnice pro nízkonapěťové aplikace (2006/95/ES).  
Použitá norma: EN 61010-1:2001 (druhé vydání).
  - Směrnice pro elektromagnetickou kompatibilitu (EMC) (2004/108/ES).\*
- \* Pouze pro výrobky s variantou řízení AR nebo AT.

Toto ES prohlášení o shodě je platné pouze tehdy, pokud je zveřejněno jako součást instalačních a provozních návodů Grundfos.

### GR: Δήλωση συμμόρφωσης EC

Εμείς, η Grundfos, δηλώνουμε με αποκλειστικά δική μας ευθύνη ότι τα προϊόντα DMH 280, DMH 281, DMH 283, DMH 285, DMH 286, DMH 287 και DMH 288 στα οποία αναφέρεται η παρούσα δήλωση, συμμορφώνονται με τις εξής Οδηγίες του Συμβουλίου περί προσέγγισης των νομοθεσιών των κρατών μελών της ΕΕ:

- Οδηγία για μηχανήματα (2006/42/ΕΚ).  
Πρότυπα που χρησιμοποιήθηκαν: EN 809:1998+A1:2009,  
EN ISO 12100-1+A1:2009,  
EN ISO 12100-2+A1:2009.
  - Οδηγία χαμηλής τάσης (2006/95/ΕΚ).  
Πρότυπο που χρησιμοποιήθηκε: EN 61010-1:2001 (δεύτερη έκδοση).
  - Οδηγία Ηλεκτρομαγνητικής Συμβατότητας (EMC) (2004/108/ΕΚ).\*
- \* Μόνο για προϊόντα με τύπο ελέγχου AR ή AT.

Αυτή η δήλωση συμμόρφωσης EC ισχύει μόνον όταν συνοδεύει τις οδηγίες εγκατάστασης και λειτουργίας της Grundfos.

### FR: Déclaration de conformité CE

Nous, Grundfos, déclarons sous notre seule responsabilité, que les produits DMH 280, DMH 281, DMH 283, DMH 285, DMH 286, DMH 287 et DMH 288, auxquels se réfère cette déclaration, sont conformes aux Directives du Conseil concernant le rapprochement des législations des Etats membres CE relatives aux normes énoncées ci-dessous :

- Directive Machines (2006/42/CE).  
Normes utilisées : EN 809:1998+A1:2009,  
EN ISO 12100-1+A1:2009,  
EN ISO 12100-2+A1:2009.
  - Directive Basse Tension (2006/95/CE).  
Norme utilisée : EN 61010-1:2001 (deuxième édition).
  - Directive Compatibilité Electromagnétique CEM (2004/108/CE).\*
- \* Uniquement pour produits avec variante de commande AR ou AT.

Cette déclaration de conformité CE est uniquement valide lors de sa publication dans la notice d'installation et de fonctionnement Grundfos.

### IT: Dichiarazione di conformità CE

Grundfos dichiara sotto la sua esclusiva responsabilità che i prodotti DMH 280, DMH 281, DMH 283, DMH 285, DMH 286, DMH 287 e DMH 288, ai quali si riferisce questa dichiarazione, sono conformi alle seguenti direttive del Consiglio riguardanti il riavvicinamento delle legislazioni degli Stati membri CE:

- Direttiva Macchine (2006/42/CE).  
Norme applicate: EN 809:1998+A1:2009,  
EN ISO 12100-1+A1:2009,  
EN ISO 12100-2+A1:2009.
  - Direttiva Bassa Tensione (2006/95/CE).  
Norma applicata: EN 61010-1:2001 (seconda edizione).
  - Direttiva EMC (2004/108/CE).\*
- \* Solo per prodotti con varianti di controllo AR o AT.

Questa dichiarazione di conformità CE è valida solo quando pubblicata come parte delle istruzioni di installazione e funzionamento Grundfos.

**HU: EK megfelelési nyilatkozat**

Mi, a Grundfos, egyedüli felelősséggel kijelentjük, hogy a DMH 280, DMH 281, DMH 283, DMH 285, DMH 286, DMH 287 és DMH 288 termékek, amelyekre jelen nyilatkozik vonatkozik, megfelelnek az Európai Unió tagállamainak jogi irányelveit összehangoló tanács alábbi előírásainak:

- Gépek (2006/42/EK).  
Alkalmazott szabványok: EN 809:1998+A1:2009,  
EN ISO 12100-1+A1:2009,  
EN ISO 12100-2+A1:2009.
- Kifeszültségű Direktíva (2006/95/EK).  
Alkalmazott szabvány: EN 61010-1:2001 (második kiadás).
- EMC Direktíva (2004/108/EK).\*

\* Csak AR illetve AT vezérlési változat esetén.

Ez az EK megfelelési nyilatkozat kizárólag akkor érvényes, ha Grundfos telepítési és üzemeltetési utasítás részeként kerül kiadásra.

**PL: Deklaracja zgodności WE**

My, Grundfos, oświadczamy z pełną odpowiedzialnością, że nasze wyroby DMH 280, DMH 281, DMH 283, DMH 285, DMH 286, DMH 287 i DMH 288, których deklaracja niniejsza dotyczy, są zgodne z następującymi wytycznymi Rady d/s ujednolicenia przepisów prawnych krajów członkowskich WE:

- Dyrektywa Maszynowa (2006/42/WE).  
Zastosowane normy: EN 809:1998+A1:2009,  
EN ISO 12100-1+A1:2009,  
EN ISO 12100-2+A1:2009.
- Dyrektywa Niskonapięciowa (LVD) (2006/95/WE).  
Zastosowana norma: EN 61010-1:2001 (drugie wydanie).
- Dyrektywa EMC (2004/108/WE).\*

\* Tylko dla produktów w wersji sterowania AR lub AT.

Deklaracja zgodności WE jest ważna tylko i wyłącznie wtedy kiedy jest opublikowana przez firmę Grundfos i umieszczona w instrukcji montażu i eksploatacji.

**RU: Декларация о соответствии ЕС**

Мы, компания Grundfos, со всей ответственностью заявляем, что изделия DMH 280, DMH 281, DMH 283, DMH 285, DMH 286, DMH 287 и DMH 288, к которым относится настоящая декларация, соответствуют следующим Директивам Совета Евросоюза об унификации законодательных предписаний стран-членов ЕС:

- Механические устройства (2006/42/ЕС).  
Применявшиеся стандарты: EN 809:1998+A1:2009,  
EN ISO 12100-1+A1:2009,  
EN ISO 12100-2+A1:2009.
- Низковольтное оборудование (2006/95/ЕС).  
Применявшийся стандарт: EN 61010-1:2001 (второе издание).
- Электромагнитная совместимость (2004/108/ЕС).\*

\* Только для насосов с блоком управления AR или AT.

Данная декларация о соответствии ЕС имеет силу только в случае публикации в составе инструкции по монтажу и эксплуатации на продукцию производства компании Grundfos.

**SE: EG-försäkran om överensstämmelse**

Vi, Grundfos, försäkrar under ansvar att produkterna DMH 280, DMH 281, DMH 283, DMH 285, DMH 286, DMH 287 och DMH 288, som omfattas av denna försäkran, är i överensstämmelse med rådets direktiv om inbördes närmande till EU-medlemsstaternas lagstiftning, avseende:

- Maskindirektivet (2006/42/EG).  
Tillämpade standarder: EN 809:1998+A1:2009,  
EN ISO 12100-1+A1:2009,  
EN ISO 12100-2+A1:2009.
- Lågspänningsdirektivet (2006/95/EG).  
Tillämpad standard: EN 61010-1:2001 (andra upplagan).
- EMC-direktivet (2004/108/EG).\*

\* Endast för produkter med styrenhetsvariant AR eller AT.

Denna EG-försäkran om överensstämmelse är endast giltig när den publiceras som en del av Grundfos monterings- och driftsinstruktion.

**CN: EC 产品合格声明书**

我们格兰富在我们的全权责任下声明，产品 DMH 280, DMH 281, DMH 283, DMH 285, DMH 286, DMH 287 和 DMH 288，即该合格证所指之产品，符合欧共体使其成员国法律趋于一致的以下欧共理事会指令：

- 机械设备指令 (2006/42/EC)。  
所用标准：EN 809:1998+A1:2009,  
EN ISO 12100-1+A1:2009,  
EN ISO 12100-2+A1:2009。
- 低电压指令 (2006/95/EC)。  
所用标准：EN 61010-1:2001 (第 2 版)。
- 电磁兼容性指令 (2004/108/EC)。\*

\* 仅对控制选项为 AR 或 AT 的型号有效。

本 EC 合格性声明仅在作为格兰富安装与操作指导手册的一部分时有效。

**NL: EC overeenkomstigheidsverklaring**

Wij, Grundfos, verklaren geheel onder eigen verantwoordelijkheid dat de producten DMH 280, DMH 281, DMH 283, DMH 285, DMH 286, DMH 287 en DMH 288 waarop deze verklaring betrekking heeft, in overeenstemming zijn met de Richtlijnen van de Raad in zake de onderlinge aanpassing van de wetgeving van de EG Lidstaten betreffende:

- Machine Richtlijn (2006/42/EC).  
Gebruikte normen: EN 809:1998+A1:2009,  
EN ISO 12100-1+A1:2009,  
EN ISO 12100-2+A1:2009.
- Laagspannings Richtlijn (2006/95/EC).  
Gebruikte norm: EN 61010-1:2001 (tweede editie).
- EMC Richtlijn (2004/108/EC).\*

\* Enkel voor producten met besturingsvariant AR of AT.

Deze EC overeenkomstigheidsverklaring is alleen geldig wanneer deze gepubliceerd is als onderdeel van de Grundfos installatie- en bedieningsinstructies.

**PT: Declaração de conformidade CE**

A Grundfos declara sob sua única responsabilidade que os produtos DMH 280, DMH 281, DMH 283, DMH 285, DMH 286, DMH 287 e DMH 288, aos quais diz respeito esta declaração, estão em conformidade com as seguintes Directivas do Conselho sobre a aproximação das legislações dos Estados Membros da CE:

- Directiva Máquinas (2006/42/CE).  
Normas utilizadas: EN 809:1998+A1:2009,  
EN ISO 12100-1+A1:2009,  
EN ISO 12100-2+A1:2009.
- Directiva Baixa Tensão (2006/95/CE).  
Norma utilizada: EN 61010-1:2001 (segunda edição).
- Directiva EMC (compatibilidade electromagnética) (2004/108/CE).\*

\* Apenas para produtos com sistema de controlo AR ou AT.

Esta declaração de conformidade CE é apenas válida quando publicada como parte das instruções de instalação e funcionamento Grundfos.

**SI: ES izjava o skladnosti**

V Grundfosu s polno odgovornostjo izjavljamo, da so naši izdelki DMH 280, DMH 281, DMH 283, DMH 285, DMH 286, DMH 287 in DMH 288, na katere se ta izjava nanaša, v skladu z naslednjimi direktivami Sveta o približevanju zakonodaje za izenačevanje pravnih predpisov držav članic ES:

- Direktiva o strojih (2006/42/ES).  
Uporabljeni normi: EN 809:1998+A1:2009,  
EN ISO 12100-1+A1:2009,  
EN ISO 12100-2+A1:2009.
- Direktiva o nizki napetosti (2006/95/ES).  
Uporabljena norma: EN 61010-1:2001 (druga izdaja).
- Direktiva o elektromagnetni združljivosti (EMC) (2004/108/ES).\*

\* Samo za izdelke z kontrolno različico AR ali AT.

ES izjava o skladnosti velja samo kadar je izdana kot del Grundfos instalacije in navodil delovanja.

**TR: EC uygunluk bildirgesi**

Grundfos olarak bu beyannameye konu olan DMH 280, DMH 281, DMH 283, DMH 285, DMH 286, DMH 287 ve DMH 288 ürünlerinin, AB Üyesi Ülkelerin kanunlarını birbirine yaklaştırma üzerine Konsey Direktifleriyle uyumlu olduğunu yalnızca bizim sorumluluğumuz altında olduğunu beyan ederiz:

- Makineler Yönetmeliği (2006/42/EC).  
Kullanılan standartlar: EN 809:1998+A1:2009,  
EN ISO 12100-1+A1:2009,  
EN ISO 12100-2+A1:2009.
- Düşük Voltaj Yönetmeliği (2006/95/EC).  
Kullanılan standart: EN 61010-1:2001 (ikinci baskı).
- EMC Direktifi (2004/108/EC).\*

\* Sadece AR ve AT kontrol değişikli için.

- İşbu EC uygunluk bildirgesi, yalnızca Grundfos kurulum ve çalıştırma talimatlarının bir parçası olarak basıldığı takdirde geçerlilik kazanmaktadır

Pfingsttal, 15th May, 2012



Ulrich Stemick  
Technical Director  
Grundfos Water Treatment GmbH  
Reetzstr. 85, D-76327 Pfingsttal, Germany

Person authorised to compile technical file and empowered to sign the EC declaration of conformity

## Original installation and operating instructions.

## CONTENTS

	Page		Page
<b>1. General information</b>	<b>4</b>	<b>9. Operation</b>	<b>28</b>
1.1 Introduction	4	9.1 Switching on/off	28
1.2 Service documentation	4	9.2 Setting the dosing capacity	28
<b>1.3 Applications</b>	<b>4</b>	9.3 Deaeration	29
1.3 Applications	4	9.4 Using the AR control unit (optional)	29
1.4 Warranty	5	9.5 Electric servomotor (optional)	29
<b>2. Safety</b>	<b>5</b>	9.6 Electronic preselection counter (optional)	29
2.1 Identification of safety instructions in this manual	5	9.7 Electrically heated dosing head (optional)	29
2.2 Qualification and training of personnel	5	<b>10. Maintenance</b>	<b>29</b>
2.3 Risks when safety instructions are not observed	5	10.1 General notes	29
2.4 Safety-conscious working	5	10.2 Diaphragm leakage control for diaphragm leakage detection	29
2.5 Safety instructions for the operator/user	5	10.3 Cleaning and maintenance intervals	30
2.6 Safety instructions for maintenance, inspection and installation work	5	10.4 Checking the oil level	30
2.7 Unauthorised modification and manufacture of spare parts	6	10.5 Cleaning the suction and discharge valves	30
2.8 Improper operating methods	6	10.6 Replacing the diaphragm and gear oil for dosing head with single diaphragm (no diaphragm leakage detection)	31
2.9 Safety of the system in the event of a failure in the dosing system	6	10.7 Replacing the diaphragm for dosing head with double diaphragm	32
<b>3. Technical data</b>	<b>6</b>	<b>11. Fault finding chart</b>	<b>36</b>
3.1 Identification	6	<b>12. Dosing curves</b>	<b>38</b>
3.2 Type key	7	<b>13. Disposal</b>	<b>47</b>
3.3 Pump types	8		
3.4 Pump performance	8		
3.5 Sound pressure level	10		
3.6 Electrical data	10		
3.7 AR control unit	10		
3.8 Required energy	10		
3.9 Ambient and operating conditions	10		
3.10 Dosing medium	10		
<b>4. Transport and storage</b>	<b>11</b>		
4.1 Delivery	11		
4.2 Unpacking	11		
4.3 Intermediate storage	11		
4.4 Return	11		
<b>5. Product description and accessories</b>	<b>12</b>		
5.1 General description	12		
5.2 Dimensional sketches	16		
5.3 Weight	18		
5.4 Stroke volume	18		
5.5 Materials	18		
5.6 Data of contact pressure gauge for diaphragm leakage detection (optional)	18		
<b>6. Installation</b>	<b>18</b>		
6.1 General information on installation	18		
6.2 Installation location	18		
6.3 Mounting	18		
6.4 Approximate values when using pulsation dampers	19		
6.5 Optimum installation	20		
6.6 Installation tips	20		
6.7 Pipe lines	21		
6.8 Connecting the suction and discharge lines	21		
<b>7. Electrical connections</b>	<b>22</b>		
7.1 Electric servomotor (optional)	22		
7.2 Electronic preselection counter (optional)	22		
7.3 Electrically heated dosing head (optional)	22		
7.4 Diaphragm controller (optional)	23		
7.5 Connecting the power supply cable	23		
<b>8. Start-up/shutdown</b>	<b>23</b>		
8.1 Initial start-up/subsequent start-up	23		
8.2 Start-up/subsequent start-up of DMH 280	24		
8.3 Start-up/subsequent start-up of DMH 281-288	25		
8.4 Setting the pressure relief valve	26		
8.5 Zero point adjustments (DMH 281-288)	27		
8.6 Operating the pump	27		
8.7 Shutdown	28		

**Warning**

*These complete installation and operating instructions are also available on [www.grundfos.com](http://www.grundfos.com).*



*Prior to installation, read these installation and operating instructions. Installation and operation must comply with local regulations and accepted codes of good practice.*

**1. General information****1.1 Introduction**

These installation and operating instructions contain all the information required for starting up and handling the DMH 28X piston diaphragm dosing pump.

If you require further information or if any problems arise, which are not described in detail in this manual, please contact the nearest Grundfos company.

**1.2 Service documentation**

If you have any questions, please contact the nearest Grundfos company or service workshop.

**1.3 Applications**

The DMH 28X pump is suitable for liquid, non-abrasive and non-flammable media strictly in accordance with the instructions in this manual.

*Explosion-proof pumps are identified from the pump and motor nameplates. An EC declaration of conformity is provided in accordance with the EC directive 94/9/EC, the so-called ATEX directive. This declaration of conformity replaces the declaration of conformity in this manual.*

**Note****Warning**

*To operate a pump which has been identified as an explosion-proof pump for the dosing of inflammable media or for operation in potentially explosive operating sites in accordance with the EC directive 94/9/EC, refer to the enclosed manual "ATEX-approved pumps" in addition to this manual.*

**Warning**

**Other applications or the operation of pumps in ambient and operating conditions, which are not approved, are considered improper and are not permitted. Grundfos accepts no liability for any damage resulting from incorrect use.**

**1.4 Warranty**

Warranty in accordance with our general terms of sale and delivery is only valid

- if the pump is used in accordance with the information within this manual.
- if the pump is not dismantled or incorrectly handled.
- if repairs are carried out by authorised and qualified personnel.

**2. Safety**

This manual contains general instructions that must be observed during installation, operation and maintenance of the pump.

This manual must therefore be read by the installation engineer and the relevant qualified personnel/operators prior to installation and start-up, and must be available at the installation location of the pump at all times.

It is not only the general safety instructions given in this "Safety" section that must be observed, but all special safety instructions given in the other sections.

**2.1 Identification of safety instructions in this manual**

If the safety instructions or other advice in this manual are not observed, it may result in personal injury or malfunction and damage to the pump. The safety instructions and other advice are identified by the following symbols:

**Warning**

**If these safety instructions are not observed, it may result in personal injury!**

**Caution**

**If these safety instructions are not observed, it may result in malfunction or damage to the equipment!**

**Note**

**Notes or instructions that make the job easier and ensure safe operation.**

Information provided directly on the pump, e.g. labelling of fluid connections, must be maintained in a readable condition at all times.

**2.2 Qualification and training of personnel**

The personnel responsible for the operation, maintenance, inspection and installation must be appropriately qualified for these tasks. Areas of responsibility, levels of authority and the supervision of the personnel must be precisely defined by the operator.

If the personnel do not have the necessary knowledge, the necessary training and instruction must be given. If necessary, training can be performed by the manufacturer/supplier at the request of the operator of the pump. It is the responsibility of the operator to make sure that the contents of this manual are understood by the personnel.

**2.3 Risks when safety instructions are not observed**

Non-observance of the safety instructions may have dangerous consequences for the personnel, the environment and the pump. If the safety instructions are not observed, all rights to claims for damages may be lost.

Non-observance of the safety instructions may lead to the following hazards:

- failure of important functions of the pump/system
- failure of specified methods for maintenance
- harm to humans from exposure to electrical, mechanical and chemical influences
- damage to the environment from leakage of harmful substances.

**2.4 Safety-conscious working**

The safety instructions in this manual, applicable national health and safety regulations and any operator internal working, operating and safety regulations must be observed.

**2.5 Safety instructions for the operator/user**

Hazardous hot or cold parts on the pump must be protected to prevent accidental contact.

Leakages of dangerous substances (e.g. hot, toxic) must be disposed of in a way that is not harmful to the personnel or the environment. Legal regulations must be observed.

Damage caused by electrical energy must be prevented (for more details, see for example the regulations of the VDE and the local electricity supply company).

**2.6 Safety instructions for maintenance, inspection and installation work**

The operator must ensure that all maintenance, inspection and installation work is carried out by authorised and qualified personnel, who have been adequately trained by reading this manual.

All work on the pump should only be carried out when the pump is stopped. The procedure described in this manual for stopping the pump must be observed.

Pumps or pump units which are used for media that are harmful to health must be decontaminated.

All safety and protective equipment must be immediately restarted or put into operation once work is complete.

Observe the points described in the initial start-up section prior to subsequent start-up.

**Warning**

**The pump must be installed in a position where it is easily accessible during operation and maintenance work.**



**Observe the flow direction of valves (indicated by an arrow on the valve)!**

**Only use the prescribed line types!**

**Electrical connections must only be carried out by qualified personnel!**

**Warning**

**Make sure that the pump is suitable for the actual dosing medium!**



**Observe the chemical manufacturer's safety instructions when handling chemicals!**

**Do not operate the pump next to closed valves.**

**Warning**

**The pump housing, control unit and sensors must only be opened by personnel authorised by Grundfos!**



**Repairs must only be carried out by authorised and qualified personnel!**

**Wear protective clothing (gloves and goggles) when working on the dosing head, connections or lines!**

**Before removing the dosing head, valves and lines, empty any remaining medium in the dosing head into a drip tray by carefully unscrewing the suction valve.**

**The resistance of the parts that come into contact with the media depends on the media, media temperature and operating pressure.**

**Caution**

**Ensure that parts in contact with the media are chemically resistant to the dosing medium under operating conditions!**

## 2.7 Unauthorised modification and manufacture of spare parts

Modification or changes to the pump are only permitted following agreement with the manufacturer. Original spare parts and accessories authorised by the manufacturer are safe to use. Using other parts can result in liability for any resulting consequences.

## 2.8 Improper operating methods

The operational safety of the supplied pump is only ensured if it is used in accordance with section 3. *Technical data*. The specified limit values must under no circumstances be exceeded.

**Explosion-proof pumps are identified from the pump and motor nameplates. An EC declaration of conformity is provided in accordance with the EC directive 94/9/EC, the so-called ATEX directive. This declaration of conformity replaces the declaration of conformity in this manual.**

Note

### Warning



**To operate a pump which has been identified as an explosion-proof pump for the dosing of inflammable media or for operation in potentially explosive operating sites in accordance with the EC directive 94/9/EC, refer to the enclosed manual "ATEX-approved pumps" in addition to this manual.**

**If the assumption is made that a safe operation is no longer possible, switch off the pump and protect it against unintentional operation.**

This action should be taken

- if the pump has been damaged.
- if the pump no longer seems to be operational.
- if the pump has been stored for an extended period of time in poor conditions.

## 2.9 Safety of the system in the event of a failure in the dosing system

DMH 28X dosing pumps are designed according to the latest technologies and are carefully manufactured and tested. However, a failure may occur in the dosing system. Systems in which dosing pumps are installed must be designed in such a way that the safety of the entire system is still ensured following a failure of the dosing pump. Provide the relevant monitoring and control functions for this.

## 3. Technical data

### 3.1 Identification



Fig. 1 DMH nameplate

Pos.	Description
1	Type designation
2	Model
3	Maximum capacity [l/h]
4	Voltage [V]
5	Frequency [Hz]
6	Product number
7	Country of origin
8	Year and week code
9	Marks of approval, CE mark, etc.
10	Maximum pressure [bar]
11	Serial number

TM03 8688 4313

### 3.2 Type key

Example:		DMH 27 - 100 B SS-L IV /SS -X -E 2 A1A1 X E0												
<b>Type range</b>												<b>Motor variant</b>	E0	PTC motor for frequency control
DMH												E1	Motor type II 2G EEx e II T3, 3 x 400 V, 50 Hz	
<b>Maximum flow [l/h]</b>												E2	Motor type II 2GD EEx de IIC T4, 3 x 400 V, 50 Hz	
<b>Maximum pressure [bar]</b>												E3	API approval	
<b>Control variant</b>												<b>Mains plug</b>	X	No plug
B	Standard											F	EU (Schuko)	
AR*	AR control unit (analog/pulse control)											B	USA, Canada	
S1	Stroke output											I	Australia, New Zealand	
AT0	Prepared for servomotor											E	Switzerland	
AT3	Servomotor, 1 x 230 V, 50/60 Hz supply, 4-20 mA control											<b>Connection, suction/discharge</b>	B6	Pipe, 4/6 mm
AT5	Servomotor, 1 x 115 V, 50/60 Hz supply, 4-20 mA control											C2	Pipe, 8/10 mm	
AT6	Servomotor, 1 x 230 V, 50/60 Hz supply, 4-20 mA control, EEx d II BT 4											C4	Pipe, 20/25 mm	
AT7	Servomotor, 1 x 115 V, 50/60 Hz supply, 4-20 mA control, EEx d II BT 4											4	Tube, 6/9 mm	
AT8	Servomotor, 1 x 230 V, 50/60 Hz supply, 4-20 mA control, 1 kΩ potentiometer											6	Tube, 9/12 mm	
AT9	Servomotor, 1 x 115 V, 50/60 Hz supply, 4-20 mA control, 1 kΩ potentiometer											B9	Tube, 19/27 mm, PVC	
<b>Dosing head variant</b>												Q	Tube, 19/27 mm and 25/34 mm	
SS	Stainless steel, DIN 1.4571											S	Tube, 3/8" / 1/2"	
Y	Hastelloy® C											A	Threaded, Rp 1/4, female	
SS-L	SS + integrated diaphragm leakage detection											A1	Threaded, Rp 3/4, female	
Y-L	Y + integrated diaphragm leakage detection											V	Threaded, 1/4" NPT, female	
SS-H	SS + heating flange in dosing head (electric)											A9	Threaded, 1/2" NPT, male	
<b>Gasket material</b>												A3	Threaded, 3/4" NPT, female	
E	EPDM											A7	Threaded, 3/4" NPT, male	
V	FKM											B1	Tube 6/12 mm/cementing d. 12 mm	
T	PTFE											B2	Tube 13/20 mm/cementing d. 25 mm	
<b>Valve ball material</b>												B3	Welding d. 16 mm	
SS	Stainless steel, DIN 1.4401											B4	Welding d. 25 mm	
Y	Hastelloy® C											<b>Valve type</b>	1	Standard
<b>Control panel position</b>												2	Spring-loaded 0.05 bar suction opening pressure; 0.05 bar discharge opening pressure	
X	No control panel											<b>Supply voltage</b>	0	Without motor, IEC flange
F	Front-mounted (opposite to the dosing head)											F	Without motor, NEMA flange (US)	
S	Side-mounted (same side as the stroke-length adjustment knob)											G	1 x 230 V, 50/60 Hz	
Sx	Side-mounted (side opposite to the stroke-length adjustment knob)											H	1 x 120 V, 50/60 Hz	
W	Wall-mounted											5	3 x 230/460 V, 60 Hz	
												E	230/400 V, 50/60 Hz 440/480 V, 60 Hz	
												K	3 x 500 V 50 Hz	

\* Only pumps up to and including 0.37 kW and only single-phase pumps

### 3.3 Pump types

The DMH 28X dosing pump is available for a variety of performance ranges in various sizes. Pump type and designation, see pump nameplate.

The following is indicated on the pump nameplate (see section 3.1 *Identification*):

- The pump type which specifies the stroke volume, connection size and performance data (see below).
- The pump serial number which is used to identify the pump.
- The most important characteristics of the pump configuration e.g. for dosing head and valve materials. They are described in section 3.2 *Type key*.
- Maximum flow rate and maximum counter-pressure.
- Mains frequency.

The following is indicated on the motor nameplate:

- required energy
- mains frequency
- power consumption
- enclosure class.

### 3.4 Pump performance

#### Performance data at maximum pump counter-pressure

Pump type		50 Hz			60 Hz		
Single pump	Double pump	Q*	p max.	Max. stroke rate	Q*	p max.	Max. stroke rate
		[l/h]	[bar]	[n/min]	[l/h]	[bar]	[n/min]
<b>DMH 280</b>							
DMH 0.6-200	DMH 0.6-200/0.6-200	0.63	200	29	0.76	200	35
DMH 1.3-200	DMH 1.3-200/1.3-200	1.45	200	63	1.74	200	76
DMH 2.2-200	DMH 2.2-200/2.2-200	2.22	200	96	2.66	200	115
DMH 2.5-200	DMH 2.5-200/2.5-200	2.81	200	120	3.37	200	144
DMH 3.3-200	DMH 3.3-200/3.3-200	3.42	200	144	-	-	-
<b>DMH 281</b>							
DMH 2-100	DMH 2-100/2-100	2	100	29	2.4	100	35
DMH 4.2-100	DMH 4.2-100/4.2-100	4.2	100	63	5	100	75
DMH 6.4-100	DMH 6.4-100/6.4-100	6.4	100	96	7.7	100	115
DMH 8-100	DMH 8-100/8-100	8	100	120	9.6	100	144
DMH 9.6-100	DMH 9.6-100/9.6-100	9.6	100	144	-	-	-
<b>DMH 283</b>							
DMH 10-100	DMH 10-100/10-100	10	100	26	12	100	31.2
DMH 19-100	DMH 19-100/19-100	19	100	54	23	100	65
DMH 27-100	DMH 27-100/27-100	27	100	75	32	100	90
DMH 33-100	DMH 33-100/33-100	33	100	92	40	100	110
DMH 40-100	DMH 40-100/40-100	40	100	112	48	100	134
DMH 55-100	DMH 55-100/55-100	55	100	153	-	-	-
<b>DMH 285</b>							
DMH 20-100	DMH 20-100/40-100	20	100	28	24	100	34
DMH 40-100	DMH 40-100/40-100	40	100	56	48	100	67
DMH 52-100	DMH 52-100/52-100	52	100	73	63	100	88
DMH 70-100	DMH 70-100/70-100	70	100	98	84	100	118
DMH 80-100	DMH 80-100/80-100	80	100	112	96	100	134
DMH 105-100	DMH 105-100/105-100	105	100	146	-	-	-
<b>DMH 286</b>							
DMH 170-50	DMH 170-50/170-50	170	50	112	204	50	134
DMH 222-50	DMH 222-50/222-50	222	50	146	-	-	-
DMH 85-50	DMH 85-50/85-50	85	50	56	102	50	67.2
DMH 111-50	DMH 111-50/111-50	111	50	73	133	50	87.6



Pump type		50 Hz			60 Hz		
Single pump	Double pump	Q*	p max.	Max. stroke rate	Q*	p max.	Max. stroke rate
		[l/h]	[bar]	[n/min]	[l/h]	[bar]	[n/min]
<b>DMH 287</b>							
DMH 9-200	DMH 9-200/9-200	9	200	28	11	200	34
DMH 18-200	DMH 18-200/18-200	18	200	56	22	200	63
DMH 23-200	DMH 23-200/23-200	23	200	73	28	200	88
DMH 31-200	DMH 31-200/31-200	31	200	98	37	200	118
DMH 36-200	DMH 36-200/36-200	36	200	112	43	200	134
DMH 50-200	DMH 50-200/50-200	50	200	146	-	-	-
<b>DMH 288</b>							
DMH 3-200	DMH 3-200/3-200	3.6	200	26	4.3	200	31
DMH 7.5-200	DMH 7.5-200/7.5-200	7.5	200	54	9.0	200	65
DMH 10-200	DMH 10-200/10-200	10.4	200	75	12.5	200	90
DMH 13-200	DMH 13-200/13-200	12.8	200	92	15.4	200	110
DMH 15-200	DMH 15-200/15-200	15.5	200	112	18.6	200	134
DMH 21-200	DMH 21-200/21-200	21	200	153	-	-	-

\* l/h per dosing head; double the capacity for double pumps.

Note

*The pump can be operated in the range between 10 % and 100 % of the maximum dosing capacity.*

### 3.4.1 Accuracy

- Dosing flow fluctuation: smaller than  $\pm 1\%$  within the control range 10-100 %
- Linearity deviation:  $\pm 1\%$  of the full scale value.

Applies to:

- water as dosing medium
- fully deaerated dosing head
- standard pump version.

### 3.4.2 Inlet pressure and counter-pressure/suction lift

#### Maximum inlet pressure

Pump type	[bar]
DMH 280	1
DMH 281	10
DMH 283	5
DMH 285	5
DMH 286	5
DMH 287	5
DMH 288	5

#### Minimum counter-pressure at the discharge valve of the pump

Pump type	[bar]
DMH 280	2
DMH 281	2
DMH 283	2
DMH 285	2
DMH 286	2
DMH 287	2
DMH 288	2

*A positive pressure difference of at least 2 bar is required between the suction valve and the discharge valve in order for the dosing pump to operate correctly.*

Note

*If the total counter-pressure (at the dosing point) and geodetic height difference between the suction valve and the dosing point is less than 2 bar (20 m WC), a pressure-loading valve must be installed immediately before the dosing point.*

#### Maximum counter-pressure\*

Pump type	p max. [bar]
DMH 280	200
DMH 281	100
DMH 283	100
DMH 285	100
DMH 286	50
DMH 287	200
DMH 288	200

\* Observe the maximum permissible temperatures.

#### Maximum suction lift\* (continuous operation) for media with a viscosity similar to water

Pump type	Maximum suction lift [m WC]
DMH 280	Flooded suction
DMH 281	1
DMH 283	1
DMH 285	1
<b>DMH 286</b>	
DMH 170-50	Flooded suction
DMH 222-50	Flooded suction
DMH 85-50	1
DMH 111-50	1
DMH 287	1
DMH 288	1

\* Applies to a filled dosing head.

### Maximum suction lift (continuous operation) for media with maximum permissible viscosity

Pump type	Maximum suction lift [m WC]
DMH 280	Flooded suction
DMH 281	Flooded suction
DMH 283	Flooded suction
DMH 285	Flooded suction
DMH 286	Flooded suction
DMH 287	Flooded suction
DMH 288	Flooded suction

### 3.5 Sound pressure level

Pump type	
DMH 280	55 ± 5 dB(A)*
DMH 281	55 ± 5 dB(A)*
DMH 283	65 ± 5 dB(A)*
DMH 285	75 ± 5 dB(A)*
DMH 286	75 ± 5 dB(A)*
DMH 287	75 ± 5 dB(A)*
DMH 288	65 ± 5 dB(A)*

\* Testing according to DIN 45635-01-KL3.

### 3.6 Electrical data

#### 3.6.1 Enclosure class

The enclosure class depends on the motor variant selected, see motor nameplate.

The specified enclosure class can only be ensured if the power supply cable is connected with the same degree of protection.

Pumps with electronics: The enclosure class is only met if the sockets are protected! The data regarding the enclosure class applies to pumps with correctly inserted plugs or screwed-on caps.

#### 3.6.2 Motor

Version: see motor and pump nameplates.

### 3.7 AR control unit

Functions of pumps with electronics:

- "Continuous operation" button for function test and dosing head deaeration
- memory function (stores a maximum of 65,000 pulses)
- two-stage tank-empty signal (e.g. via Grundfos tank empty sensor)
- stroke signal/pre-empty signal (adjustable), e.g. as a feedback to the control room
- dosing controller function (only with sensor - optional)
- diaphragm leakage detection (only with sensor - optional)
- access-code-protected settings
- remote on/off
- hall sensor
- operating hours counter
- motor monitoring.

Operating modes:

- manual  
Stroke frequency: manually adjustable between zero and maximum
- contact signal control  
Multiplier (1:n) and divisor (n:1)
- current signal control 0-20 mA/4-20 mA  
Adjustment of stroke frequency proportional to the current signal. Weighting of current input.

### 3.7.1 Inputs and outputs

#### Inputs

Contact signal	Maximum load: 12 V, 5 mA
Current 0-20 mA	Maximum load: 22 Ω
Remote on/off	Maximum load: 12 V, 5 mA
Two-stage tank-empty signal	Maximum load: 12 V, 5 mA
Dosing controller and diaphragm leakage sensor	

#### Outputs

Current 0-20 mA	Maximum load: 350 Ω
Error signal	Maximum ohmic load: 50 VDC/75 VAC, 0.5 A
Stroke signal	Contact time/stroke: 200 ms
Pre-empty signal	Maximum ohmic load: 50 VDC/75 VAC, 0.5 A

#### AR control unit factory settings

- Inputs and outputs: NO (normally open)  
or
- inputs and outputs: NC (normally closed).

### 3.8 Required energy

#### Power supply for AC voltage

Rated voltage	Permissible deviation from rated value
230/400 V	± 10 %
240/415 V	± 10 %
115 V	± 10 %

#### Maximum permissible mains impedance

(0.084 + j 0.084) Ohm (testing according to DIN EN 61000-3-11). These details apply to 50 Hz.

### 3.9 Ambient and operating conditions

- Permissible air humidity: max. relative humidity:  
70 % at +40 °C, 90 % at +35 °C.

**Caution** *The installation site must be under cover!  
Do not install outdoors!*

#### 3.9.1 DMH with motor labelled for coolant temperature -20 °C ≤ T<sub>amb</sub> ≤ 40 °C

- Permissible ambient temperature: 0 °C (standard) to +40 °C (for an installation height up to 1000 m above sea level)
- Pumps with minimum T<sub>amb</sub> -20 °C available on request
- Permissible storage temperature: -20 °C to +50 °C.

#### 3.9.2 DMH with motor labelled for coolant temperature -20 °C ≤ T<sub>amb</sub> ≤ 55 °C and with dosing head material stainless steel or PVDF

- Permissible ambient temperature: 0 °C (standard) to +55 °C (for an installation height up to 1000 m above sea level)
- Pumps with minimum T<sub>amb</sub> -20 °C available on request
- Permissible storage temperature: -20 °C to +55 °C.

**Note** *Observe the nameplate of the motor.*

#### Pumps with AR control unit only

Maximum permissible mains impedance: 0.084 + j 0.084 Ω (testing according to EN 61000-3-11).

### 3.10 Dosing medium

**Note** *In the event of questions regarding the material resistance and suitability of the pump for specific dosing media, please contact Grundfos.*

The dosing medium must have the following basic characteristics for the standard pumps:

- liquid

- non-abrasive  
The dosing of abrasive media is possible with certain versions, on request.
- non-inflammable  
The dosing of inflammable media is possible with certain versions of explosion-proof pumps, in accordance with ATEX.

#### Maximum permissible viscosity at operating temperature\*

Applies to:

- Newtonian liquids
- non-degassing media
- media without suspended matter
- media with a density similar to water.

Note

**Note that the viscosity increases with decreasing temperature!**

Pump type	Up to stroke rate 63 [n/min]	Stroke rate 64-120 [n/min]	From stroke rate 121 [n/min]
	Maximum viscosity* [mPa s]		
DMH 280	5	5	5
DMH 281	100	50	5
DMH 283	100	50	5
DMH 285	100	50	5
DMH 286	100	50	5
DMH 287	100	50	5
DMH 288	100	50	5

\* The stated values are approximate values and apply to the standard pumps.

#### Permissible media temperature

Dosing head material	Min. media temperature	Max. media temperature
	p < 200 bar	
	[°C]	[°C]
Stainless steel, DIN 1.4571*	-10	90
Stainless steel, DIN 2.4610*	-10	90

\* For SIP/CIP applications (not with ATEX): A temperature of 145 °C at a counter-pressure of max. 2 bar is permitted for a short period (15 minutes).



#### Warning

**Observe the chemical manufacturer's safety instructions when handling chemicals!**

**The dosing medium must be in liquid form!**

**Observe the freezing and boiling points of the dosing medium!**

**The resistance of the parts that come into contact with the media depends on the media, media temperature and operating pressure.**

**Ensure that parts in contact with the media are chemically resistant to the dosing medium under operating conditions!**

**Make sure that the pump is suitable for the actual dosing medium!**

Caution

## 4. Transport and storage

**Do not throw or drop the pump.**

Caution

**Do not use the protective packaging as transport packaging.**

### 4.1 Delivery

The DMH 28X dosing pumps are supplied in different packaging, depending on pump type and the overall delivery. For transport and intermediate storage, use the correct packaging to protect the pump against damage.

### 4.2 Unpacking

Retain the packaging for future storage or return, or dispose of the packaging in accordance with local regulations.

### 4.3 Intermediate storage

See section 3.9 *Ambient and operating conditions*.

### 4.4 Return

The pump must be thoroughly cleaned before it is returned or stored. It is essential that there are no traces of toxic or hazardous media remaining on the pump. Drain the oil from the drive mechanism and package the pump correctly.

**Grundfos accepts no liability for damage**

**caused by incorrect transportation, missing or unsuitable packaging of the pump, residual media or leaking oil!**

Caution

Before returning the pump to Grundfos Water Treatment for service, the **safety declaration** at the end of these instructions must be filled in by authorised personnel and attached to the pump in a visible position.

**If a pump has been used for a medium which is**

**injurious to health or toxic, the pump will be classified as contaminated.**

Caution

If Grundfos Water Treatment is requested to service the pump, it must be ensured that the pump is free from substances that can be injurious to health or toxic. If the pump has been used for such substances, the pump must be cleaned before it is returned.

If proper cleaning is not possible, all relevant information about the chemical must be provided.

If the above is not fulfilled, Grundfos Water Treatment can refuse to accept the pump for service. Possible costs of returning the pump are paid by the customer.

The safety declaration can be found at the end of these instructions.

**The replacement of the power supply cable must be carried out by an authorised Grundfos service workshop.**

Caution

## 5. Product description and accessories

### 5.1 General description

The DMH 28X are oscillatory positive-displacement pumps with hydraulic diaphragm control. The operation procedure of the dosing pump is shown in the sectional drawing. See figs 2 to 6.

The rotational movement of the drive motor (1p) is converted via the worm gearing (2p) and eccentric (3p) into the oscillatory suction and stroke movement of the piston (6p). The piston has a hollow bore and a row of radial control holes, which provide a hydraulic connection between the drive area and the piston stroke area. The sliding plug (5p) envelops the holes during the stroke and seals the stroke area from the drive area.

The hydraulic excursion of the solid PTFE diaphragm (Q) displaces an equivalent volume of dosing medium from the dosing head (2) into the discharge line. With the suction stroke, the piston creates a low pressure, which propagates in the dosing head, the ball valve (3b) on the dosing side closes and the dosing medium flows through the suction valve (3a) into the dosing head.

The stroke volume size is solely determined by the position of the sliding plug. The active stroke length and corresponding average dosing flow can therefore be changed continuously and linearly from 10 % to 100 % using the stroke-length adjustment knob and Nonius (L).

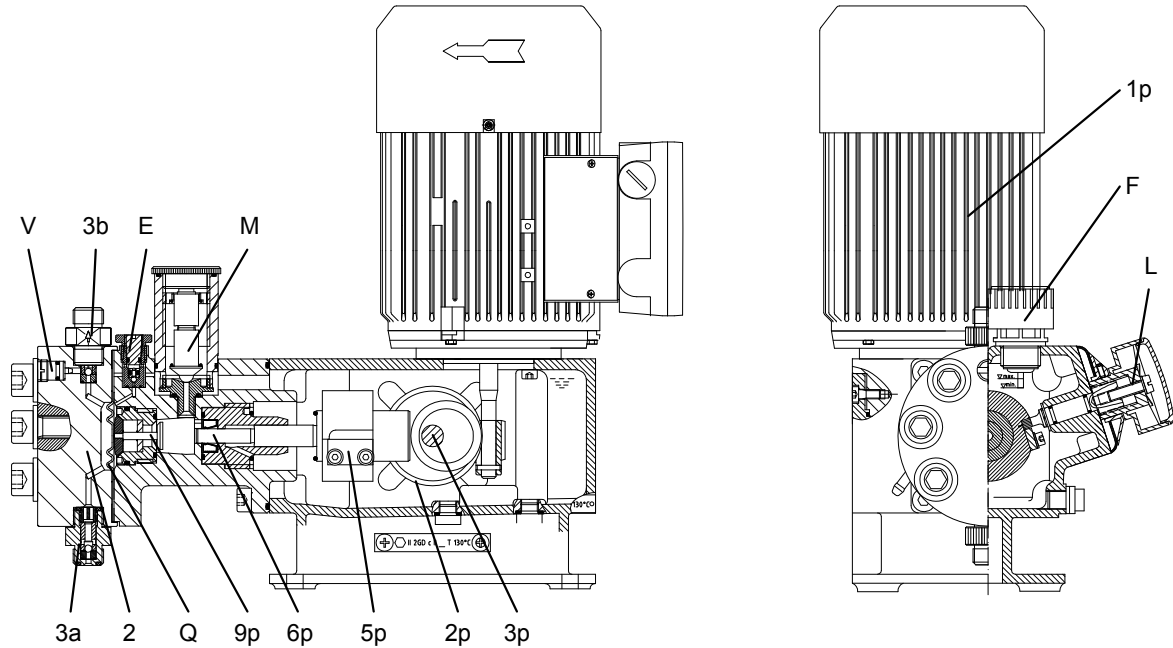

Fig. 2 DMH 280

TM03 6855 4506

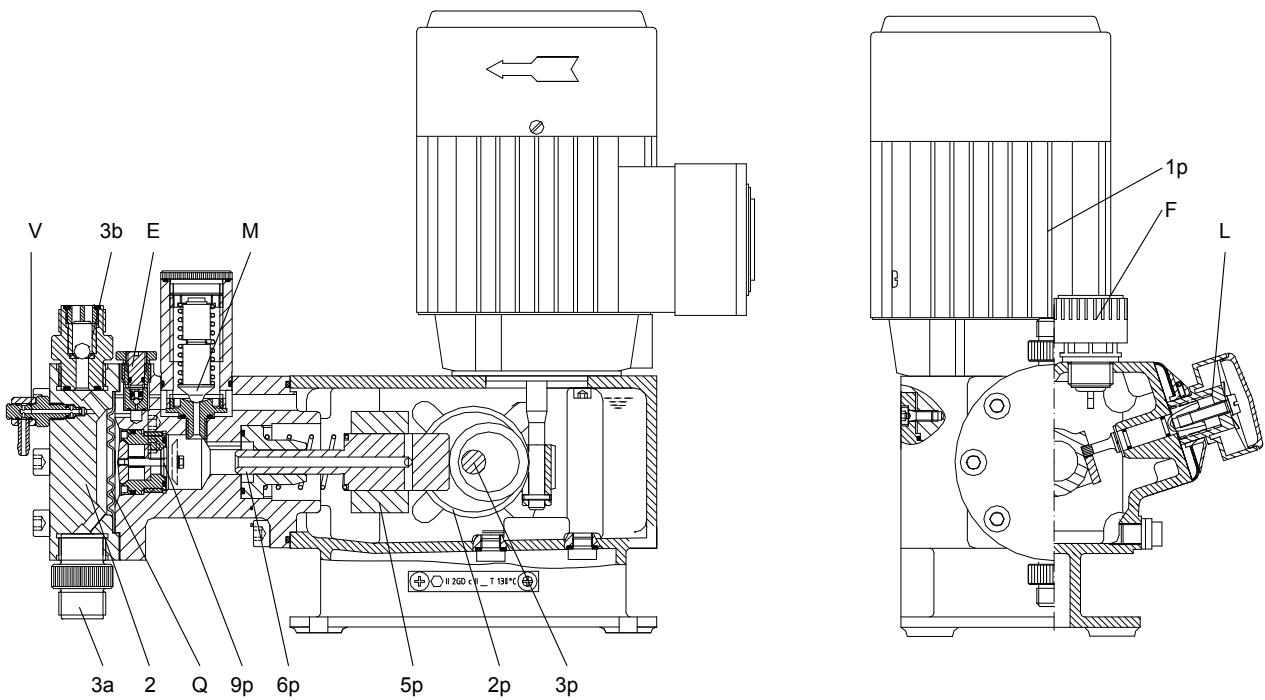

Fig. 3 DMH 281

TM03 6856 4506

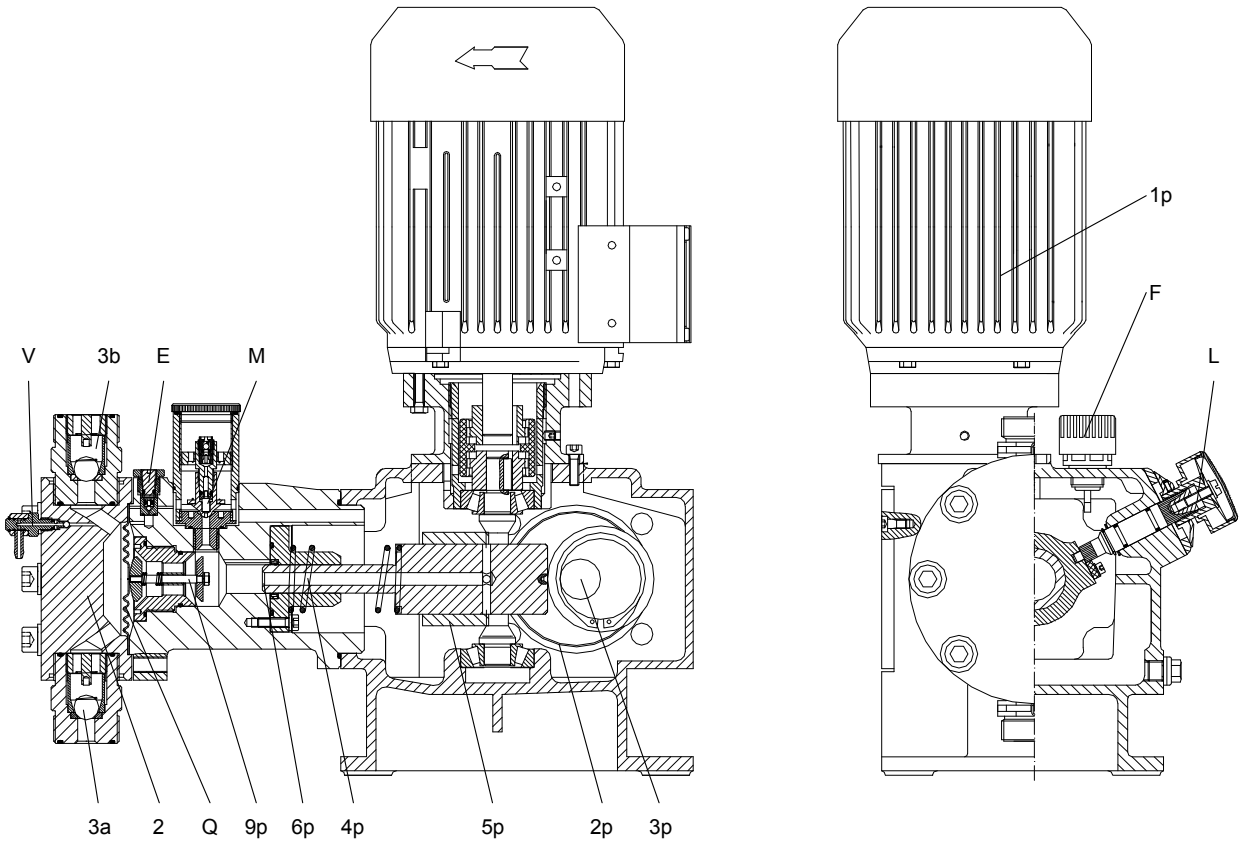

Fig. 4 DMH 283

TM03 6857 4506

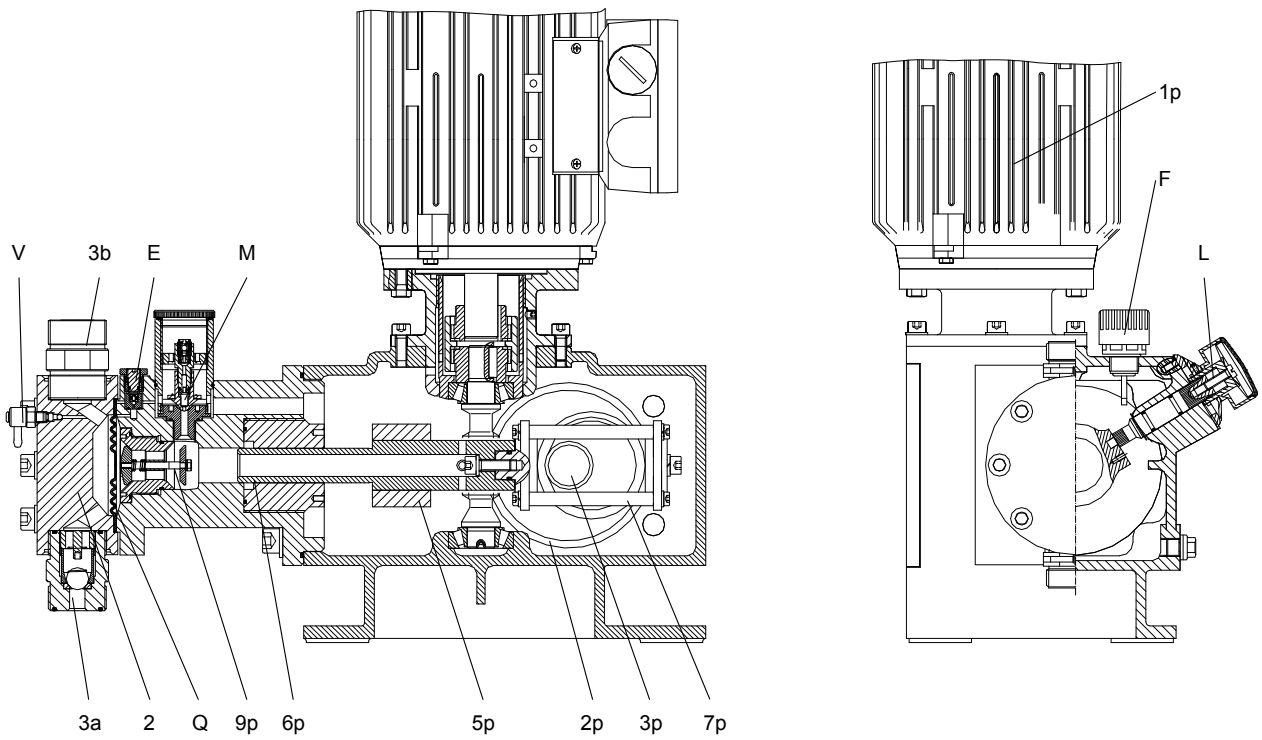

Fig. 5 DMH 285, 286, 287

TM03 6858 4506

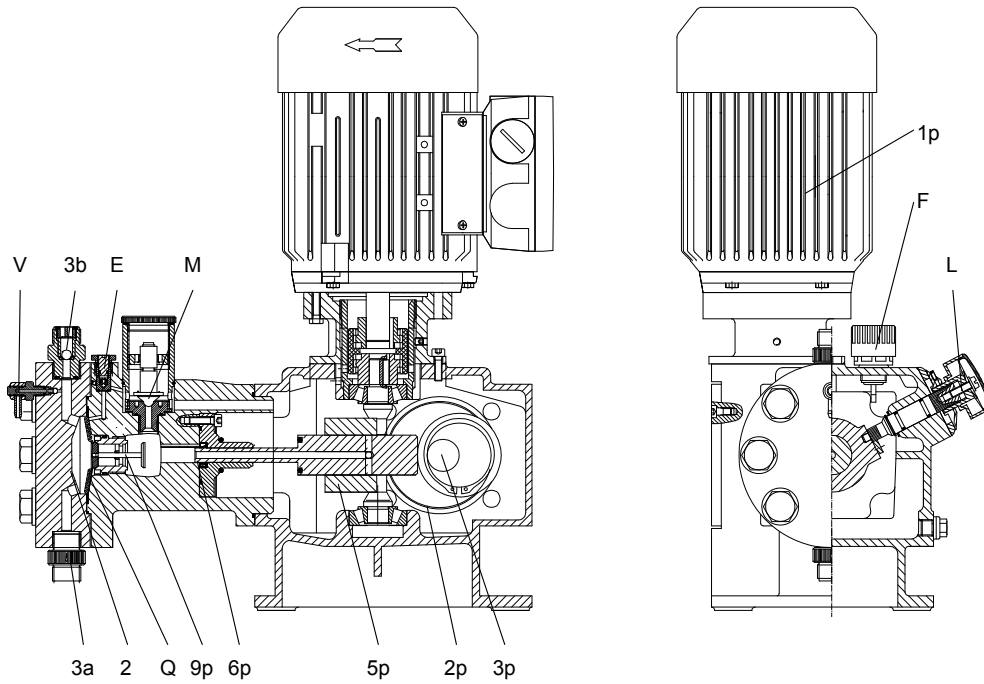

Fig. 6 DMH 288

Pos.	Components
1p	Motor
2p	Worm gearing
3p	Eccentric
4p	Recuperating spring (not with drive size 3)
5p	Sliding plug
6p	Piston
7p	Crank
M	Combined overpressure and degassing valve
E	Degassing valve
9p	Diaphragm protection system (AMS)
Q	Dosing diaphragm
2	Dosing head
V	Dosing head deaeration screw
3a	Suction valve
3b	Discharge valve
L	Stroke-length adjustment knob
F	Oil-filling screw with dipstick

**5.1.1 Combined overpressure and degassing valve**

The combined overpressure and degassing valve (M) opens if there is an excessive pressure build-up in the dosing system and provokes the constant degassing of the hydraulic medium.

**5.1.2 Diaphragm protection system AMS**

The diaphragm protection system AMS (9p) has a keypad, which is connected to the dosing diaphragm. The dosing diaphragm oscillates freely in the dosing head and cannot be overstretched due to a fault in the dosing system since the diaphragm protection valve closes if such a fault occurs.

**5.1.3 Double-diaphragm system/diaphragm leakage detection (optional)**

**General**

The piston diaphragm and high-tech dosing pumps with drift-free diaphragm leakage detection are equipped with the following:

- dosing head with PTFE double-diaphragm system
- ball non-return valve with built-in contact pressure gauge.

**Double-diaphragm system**

Dosing pumps with a double-diaphragm system with no diaphragm leakage detection have no pressure gauge. In this case the ball non-return valve is fitted with a locking unit. The valve, however, can be retrofitted with a contact pressure gauge.

**Ball non-return valve**

In order for the diaphragm leakage detection to work and to protect the diaphragms, the gap must be fully deaerated. Dosing heads with a double diaphragm are equipped with a ball non-return valve (T) to prevent air from flowing back during the filling and deaeration process (2u).

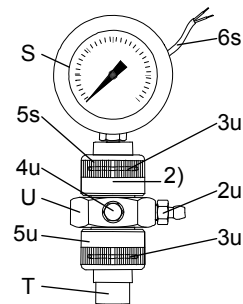

Fig. 7 Contact pressure gauge

Pos.	Components
S	Contact pressure gauge
T	Ball non-return valve
U	Connection piece

2) For dosing heads with a double diaphragm with no contact pressure gauge (no diaphragm leakage detection), a locking unit is fitted instead of the contact pressure gauge.

TM03 6859 4506

TM03 6453 4506

### Functional principle of diaphragm leakage detection

The non-return valve and the gap between the diaphragms are factory-filled with a separating agent (paraffin oil). They are set in such a way during start-up on the test stand that there is always a hydraulically separated equilibrium between the valve and diaphragm gap (the pressure gauge indicates "0" when the pump is running and when it is stopped).

If one of these diaphragms breaks, the dosing or hydraulic medium penetrates into the gap between the diaphragms and, when the ball is removed, into the valve. The system pressure is therefore impinged on the valve and the contact pressure gauge is activated. Depending on the design of the system, the electrically isolated reed contact can trigger an alarm device or the pump can be switched off.

The contact is triggered at the preset pressure as is shown in the table below:

Description/use	Set pressure [bar]
For pumps 16 to 100 bar Pressure gauge 0 to 100 bar	10
For pumps 16 to 100 bar Explosion-proof pressure gauge 0 to 100 bar	10
For pumps up to 200 bar Pressure gauge 0 to 200 bar	10
For pumps up to 200 bar Explosion-proof pressure gauge 0 to 200 bar	10



#### **Warning**

***The contact pressure gauge (Ex) in explosion-proof version with switch amplifier should be used if the pump is fitted with an explosion-proof motor.***

5.2 Dimensional sketches

5.2.1 DMH 280, 281

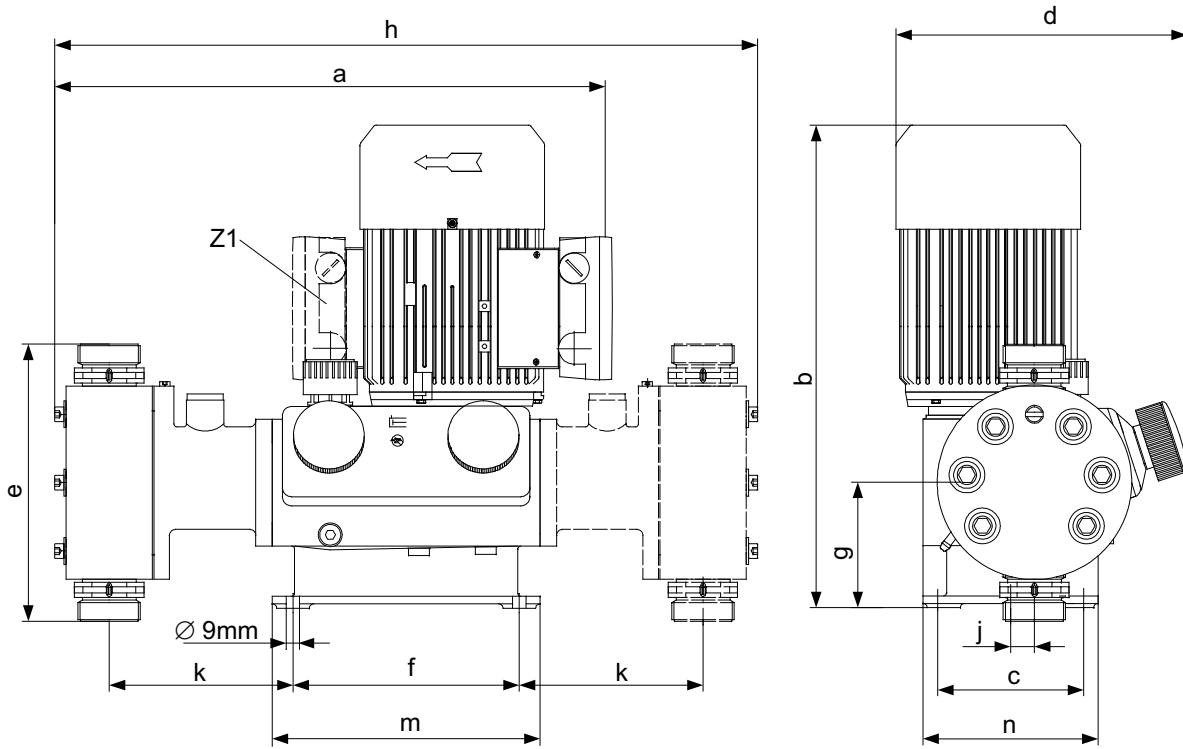

Fig. 8 DMH 280, 281

Pos.	Description
Z1	For double pump, motor turned by 180 °

Pump type	a	b	c	d	e	f	g	h	j	k	n	m
DMH 280	365	336	98	192	142	152	86	465	16	114	118	180
DMH 281	348	336	98	192	155	152	86	432	16	114	118	180

Measurements in mm.

TM03 6860 1612



5.2.2 DMH 283, 285, 286, 287, 288

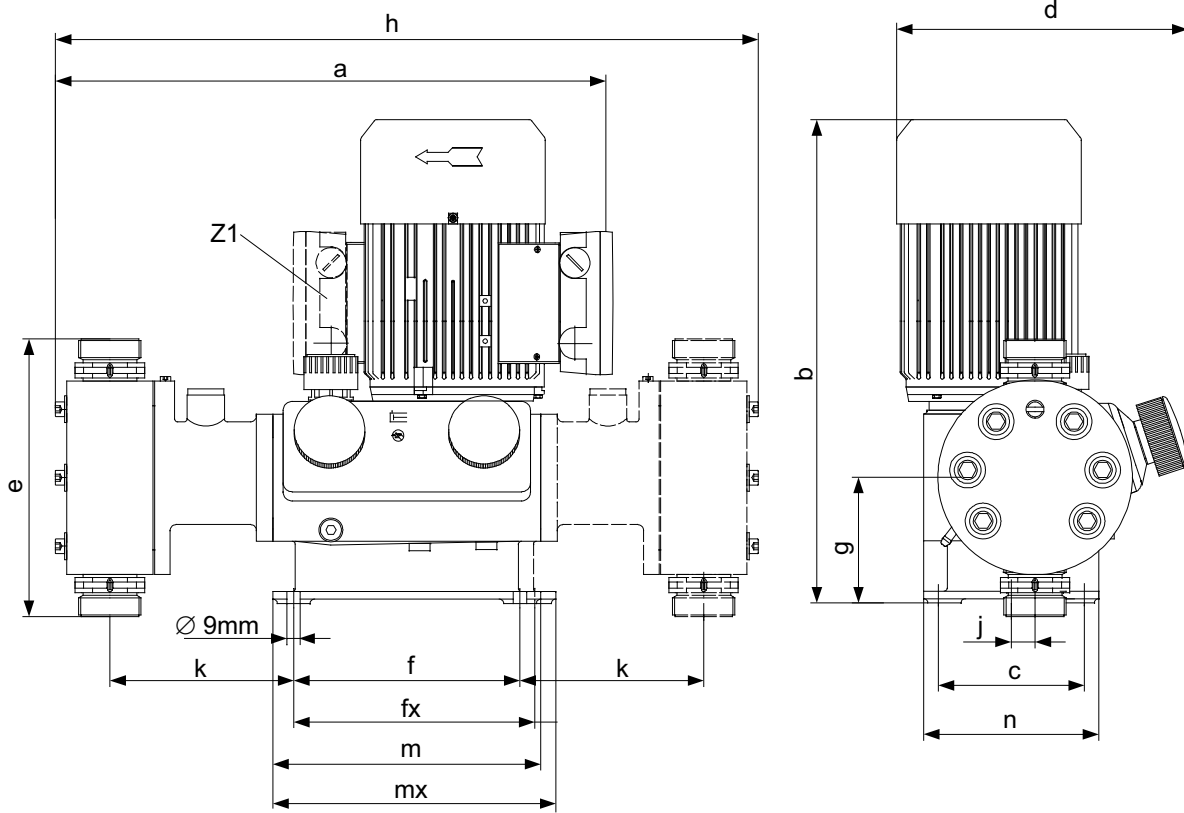

Fig. 9 DMH 283, 285, 286, 287, 288

Pos.	Description
Z1	For double pump, motor turned by 180 °
fx, mx	For double pumps

Pump type	a	b	c	d	e	f	fx	g	h	j	k	n	m	mx
DMH 283	437	493	156	254	211	185	260	126	706	10	182	180	225	300
DMH 285	510	553	146	274	179	240	333	129	820	25	187	195	290	382
DMH 286	510	553	146	274	234	240	333	129	820	25	191	195	290	382
DMH 287	490	553	170	274	208	240	333	129	814	25	176	195	290	382
DMH 288	425	492	156	156	208	185	260	126	700	10	173	180	225	300

Measurements in mm.

TN03 6861 1612

## 5.3 Weight

Pump type	Dosing head material	Weight [kg]	
		Single pump	Double pump
DMH 280	Stainless steel 1.4571, 2.4610	13.7	20.4
DMH 281	Stainless steel 1.4571, 2.4610	13	19
DMH 283	Stainless steel 1.4571, 2.4610	36	54
DMH 285	Stainless steel 1.4571, 2.4610	43	64
DMH 286	Stainless steel 1.4571, 2.4610	45	71
DMH 287	Stainless steel 1.4571, 2.4610	45	71
DMH 288	Stainless steel 1.4571, 2.4610	36	54

## 5.4 Stroke volume

Pump type	Stroke volume [cm <sup>3</sup> ]
DMH 280	0.35
DMH 281	1.1
DMH 283	6
DMH 285	12
DMH 286	25.3
DMH 287	5.4
DMH 288	2.33

## 5.5 Materials

### Pump housing material

- Pump housing: Al 226.

### AR control unit enclosure

- Upper part of enclosure: PPO blend
- Lower part of enclosure: aluminium.



#### Warning

**Observe the chemical manufacturer's safety instructions when handling chemicals!**

**Make sure that the pump is suitable for the actual dosing medium!**

**The resistance of the parts that come into contact with the media depends on the media, media temperature and operating pressure.**

#### Caution

**Ensure that parts in contact with the media are chemically resistant to the dosing medium under operating conditions!**

#### Note

**Further information on resistance with regard to the media, media temperature and operating pressure is available on request.**

## 5.6 Data of contact pressure gauge for diaphragm leakage detection (optional)

The contact pressure gauge has a reed switch with electrically isolated contact output, maximum switching power 10 W for DC current or 10 VA for AC current. The maximum switching voltage is 100 V, maximum switching current 0.5 A.

The switching function is set up as an NC contact, i.e. if the diaphragm breaks, the current circuit is interrupted.

The pressure gauge has a 2-metre cable.

## 6. Installation

### 6.1 General information on installation



#### Warning

**Observe the specifications for the installation location and range of applications described in section 3. Technical data.**



#### Warning

**Faults, incorrect operation or faults on the pump or system can, for example, lead to excessive or insufficient dosing, or the permissible pressure may be exceeded. Consequential faults or damage must be evaluated by the operator and appropriate precautions must be taken to avoid them!**



#### Warning

**Risk of hot surfaces!**

**Pumps with AC motors may become hot. Allow a minimum space of 100 mm to the fan cover!**

**A positive pressure difference of at least 2 bar is required between the suction valve and the discharge valve in order for the dosing pump to operate correctly.**

#### Note

**If the total counter-pressure (at the dosing point) and geodetic height difference between the suction valve and the dosing point is less than 2 bar (20 m WC), a pressure-loading valve must be installed immediately before the dosing point.**

### 6.2 Installation location

#### 6.2.1 Space required for operation and maintenance

#### Note

**The pump must be installed in a position where it is easily accessible during operation and maintenance work.**

Maintenance work on the dosing head and the valves must be carried out regularly.

- Provide sufficient space for removing the dosing head and the valves.

#### 6.2.2 Permissible ambient influences

See section 3.9 Ambient and operating conditions.

#### Note

**The installation site must be under cover! Do not install outdoors!**

#### 6.2.3 Mounting surface

The pump must be mounted on a flat surface.

### 6.3 Mounting

- Mount the pump on a console or pump foundation using four screws.

#### Note

**The flow must run in the opposite direction to gravity!**

## 6.4 Approximate values when using pulsation dampers

**Risk of damage to the system!**

*It is always recommended to use pulsation dampers for large high-speed pumps!*

**Caution**

*Since the pulsation is influenced by many factors, a system-specific calculation is essential. Request a calculation from our calculation program.*

The table below indicates the approximate values and the suction line length for which suction pulsation dampers are required. The values apply to 50 Hz operation when water or similar liquids are dosed.

Pump type	Stroke rate [n/min]	Nominal width of suction line	Maximum length of suction line [m]
<b>DMH 280</b>			
DMH 0.6-200	29	DN 4	8
DMH 1.3-200	63	DN 4	8
DMH 2.2-200	96	DN 4	8
DMH 2.5-200	120	DN 4	8
DMH 3.3-200	144	DN 4	8
<b>DMH 281</b>			
DMH 2-100	29	DN 8	8
DMH 4.2-100	63	DN 8	8
DMH 6.4-100	96	DN 8	8
DMH 8-100	120	DN 8	8
DMH 9.6-100	144	DN 8	8
<b>DMH 283</b>			
DMH 10-100	26	DN 20	8
DMH 19-100	54	DN 20	8
DMH 27-100	75	DN 20	8
DMH 33-100	92	DN 20	8
DMH 40-100	112	DN 20	8
DMH 55-100	153	DN 20	6
<b>DMH 285</b>			
DMH 20-100	28	DN 20	8
DMH 40-100	56	DN 20	8
DMH 52-100	73	DN 20	8
DMH 70-100	98	DN 20	6
DMH 80-100	112	DN 20	5
DMH 105-100	146	DN 20	3
<b>DMH 286</b>			
DMH 170-50	112	DN 20	2.5
DMH 222-50	146	DN 20	1.5
DMH 85-50	56	DN 20	2.5
DMH 111-50	73	DN 20	2.5

Pump type	Stroke rate [n/min]	Nominal width of suction line	Maximum length of suction line [m]
<b>DMH 287</b>			
DMH 9-200	28	DN 8	8
DMH 18-200	56	DN 8	8
DMH 23-200	73	DN 8	4
DMH 31-200	98	DN 8	3
DMH 36-200	112	DN 8	2
DMH 50-200	146	DN 8	1
<b>DMH 288</b>			
DMH 3-200	26	DN 8	8
DMH 7.5-200	54	DN 8	8
DMH 10-200	75	DN 8	4
DMH 13-200	92	DN 8	3
DMH 15-200	112	DN 8	2
DMH 21-200	153	DN 8	1

### 6.5 Optimum installation

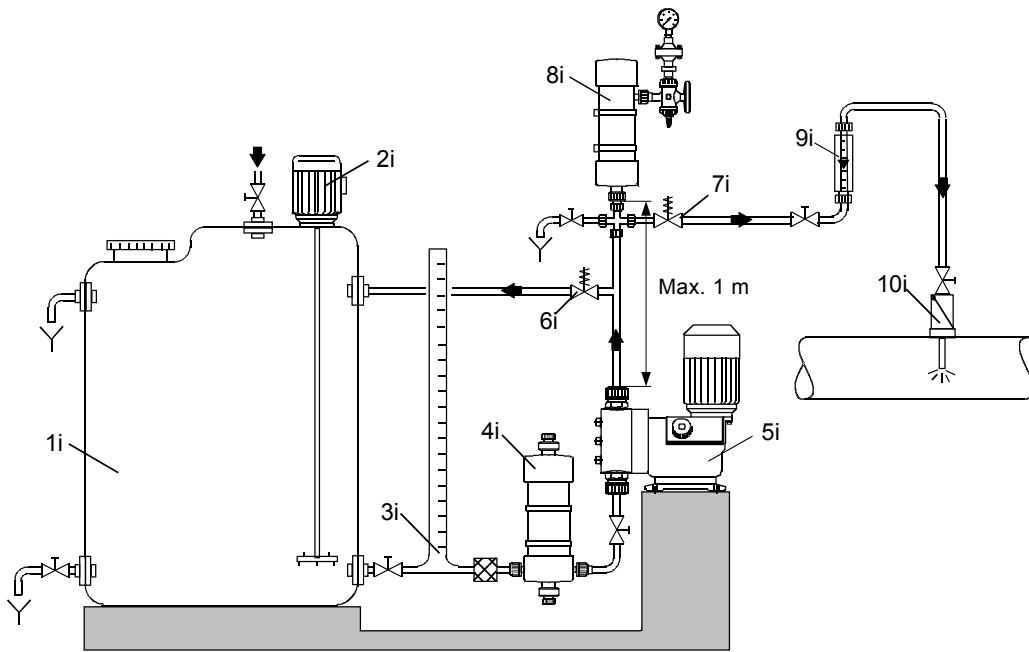

Fig. 10 Example of optimum installation

Pos.	Components
1i	Dosing tank
2i	Electric agitator
3i	Extraction device
4i	Suction pulsation damper
5i	Dosing pump
6i	Relief valve
7i	Pressure-loading valve
8i	Pulsation damper
9i	Measuring glass
10i	Injection unit

- For non-degassing media with a viscosity similar to water, the pump can be mounted on the tank (observe the maximum suction lift).
- Flooded suction preferred.
- For media with a tendency to sedimentation, install the suction line with filter (13i) so that the suction valve remains a few millimetres above the possible level of sedimentation.

### 6.6 Installation tips

- For easy deaeration of the dosing head, install a ball valve (11i) with bypass line (back to the dosing tank) immediately after the discharge valve.
- In the case of long discharge lines, install a non-return valve (12i) in the discharge line.

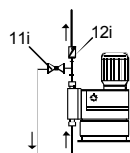

Fig. 11 Installation with ball valve and non-return valve

- When installing the suction line, observe the following:
  - Keep the suction line as short as possible. Prevent it from becoming tangled.
  - If necessary, use swept bends instead of elbows.
  - Always route the suction line up towards the suction valve.
  - Avoid loops which may cause air bubbles.

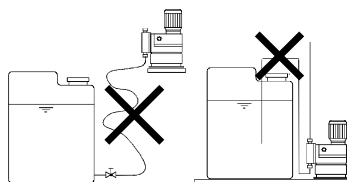

Fig. 12 Installation of suction line

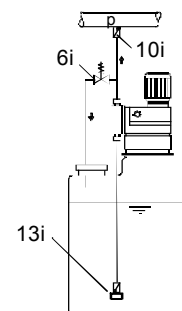

Fig. 13 Tank installation

- Note for suction-side installation: Depending on the dosing flow and the line length, it may be necessary to install a properly sized pulsation damper (4i) immediately before the pump suction valve.

**Note** Observe section 6.4 Approximate values when using pulsation dampers and, if necessary, request a system-specific calculation from our calculation program.

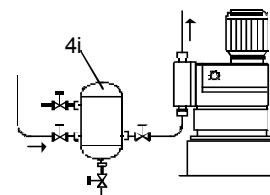

Fig. 14 Installation with suction-side pulsation damper

TM03 6296 4506

TM03 6299 4506

TM03 6297 4506

TM03 6298 4506

TM03 6300 4506

- Note for discharge-side installation: Depending on the dosing flow and the line length, it may be necessary to install a properly sized pulsation damper (8i) on the discharge side.

**To protect the system, use pulsation dampers (8i) for rigid piping longer than 2 metres and tubing longer than 3 metres, depending on pump type and size.**

Note

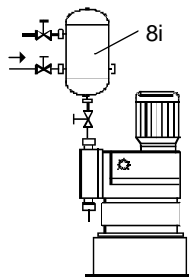

Fig. 15 Installation with discharge-side pulsation damper

**Risk of damage to the system!**  
 It is always recommended to use pulsation dampers for large high-speed pumps!  
**Caution** Since the pulsation is influenced by many factors, a system-specific calculation is essential. Request a calculation from our calculation program.

- For degassing and viscous media: flooded suction.
- Install a filter in the suction line to prevent the valves from becoming choked.
- To protect the dosing pump and the discharge line against excessive pressure build-up, install a relief valve (6i) in the discharge line.

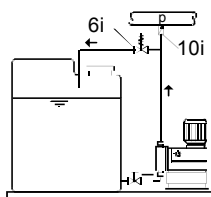

Fig. 16 Installation with relief valve

**With open outflow of the dosing medium or a counter-pressure below 2 bar**

- Install a pressure-loading valve (7i) immediately before the outlet or the injection unit.
- A positive pressure difference of at least 2 bar must be ensured between the counter-pressure at the injection point and the pressure of the dosing medium at the pump suction valve.
- If this cannot be ensured, install a pressure-loading valve (7i) in the discharge line.

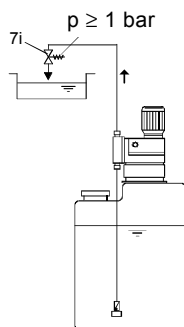

Fig. 17 Installation with pressure-loading valve

- To avoid the siphon effect, install a pressure-loading valve (7i) in the discharge line and, if necessary, a solenoid valve (14i) in the suction line.

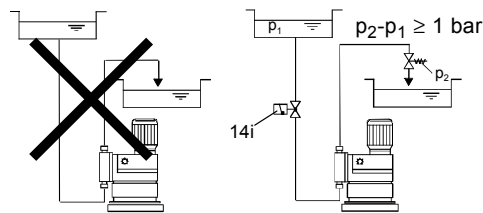

Fig. 18 Installation to avoid the siphon effect

## 6.7 Pipe lines

### 6.7.1 General

#### Warning

To protect the dosing system against excessive pressure build-up, install a relief valve in the discharge line.

Only use the prescribed line types!

All lines must be free from strain!

Avoid loops and buckles in the tubes!

Keep the suction line as short as possible to avoid cavitation!

If necessary, use swept bends instead of elbows.

Observe the chemical manufacturer's safety instructions when handling chemicals!

Make sure that the pump is suitable for the actual dosing medium!

The flow must run in the opposite direction to gravity!

The resistance of the parts that come into contact with the media depends on the media, media temperature and operating pressure.

Ensure that parts in contact with the media are chemically resistant to the dosing medium under operating conditions!



Caution

### 6.8 Connecting the suction and discharge lines



#### Warning

All lines must be free from strain!

Only use the prescribed line types!

- Connect the suction line to the suction valve.
  - Install the suction line in the tank so that the foot valve remains 5 to 10 mm above the bottom of the tank or the possible level of sedimentation.
- Connect the discharge line to the discharge valve.

#### Connection of DN 20 pipe lines

- Depending on the pipe material and connection, glue the pipe (PVC), weld it (PP, PVDF or stainless steel) or press it in (stainless steel).
- Fit the gasket.
- Screw the pipe on the valve using the union nut.

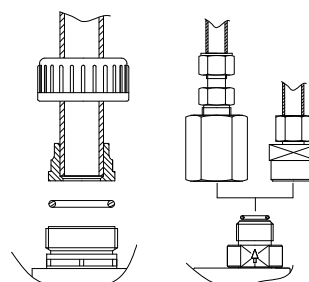

Fig. 19 Connection of DN 20 pipe lines

TM03 6301 4506

TM03 6302 4506

TM03 6303 4506

TM03 6304 4506

TM03 6457 4506

### 6.8.1 Connecting the dosing head deaeration

The dosing head is equipped with a deaeration screw (V) and hose nipple (I). During deaeration, dosing medium leaks from the hose nipple. This may also happen during normal operation. The dosing medium should either be collected directly or via a deaeration line in a suitable container.

**Warning**

**Risk of injuries caused by the dosing medium. Dosing medium leaks from the hose nipple (I) of the deaeration line. If the pressure is high, the medium may squirt out. Turn the hose nipple (I) in the right direction, or drain the dosing medium through a suitable hose. Observe chemical resistance!**



When using a deaeration line,

- connect the deaeration line (J) to the deaeration screw (V/I).
- Shorten the deaeration line (J) to at least 10 mm above the maximum tank level.
- Insert the deaeration line (J) downwards into the dosing tank or collection container without loops. Do not immerse in the dosing medium.

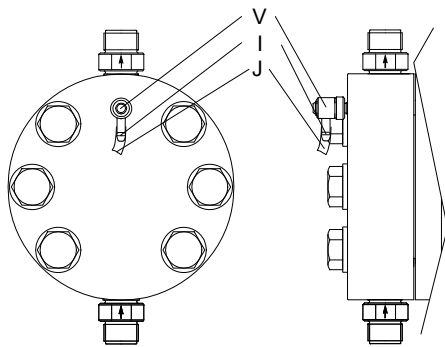

TM03 6862 4506

Fig. 20 Dosing head deaeration

### 6.8.2 Connecting a liquid-heated dosing head (optional)

As an option, liquid-heated dosing heads are available in stainless steel.

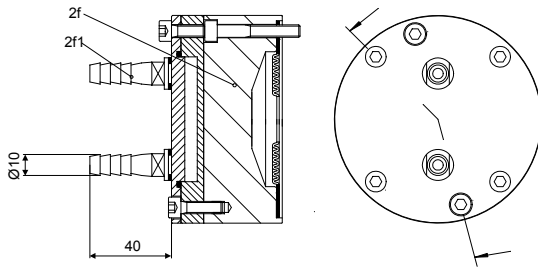

TM03 6459 4506

Fig. 21 Liquid-heated dosing head

Pos.	Components
2f	Dosing head, liquid-heated
2f1	Hose nipple, DN 10 connection

Required characteristics of heating liquid:

- The heating liquid must not chemically attack stainless steel.
- Maximum permissible pressure:  $p_{max.} = 3 \text{ bar}$ .
- Maximum permissible temperature:  $t_{max.} = 100 \text{ }^\circ\text{C}$ .

## 7. Electrical connections

Make sure that the pump is suitable for the electricity supply on which it will be used.

**Warning**

**Electrical connections must only be carried out by qualified personnel!**

**Disconnect the power supply before connecting the power supply cable and the relay contacts!**

**Observe the local safety regulations!**

**The pump housing must only be opened by personnel authorised by Grundfos!**

**Protect the cable connections and plugs against corrosion and humidity.**

**Only remove the protective caps from the sockets that are being used.**



### 7.1 Electric servomotor (optional)

To connect the servomotor to the power supply, see the installation and operating instructions for the servomotor.

### 7.2 Electronic preselection counter (optional)

To connect the preselection counter to the power supply, see the installation and operating instructions for the counter.

### 7.3 Electrically heated dosing head (optional)

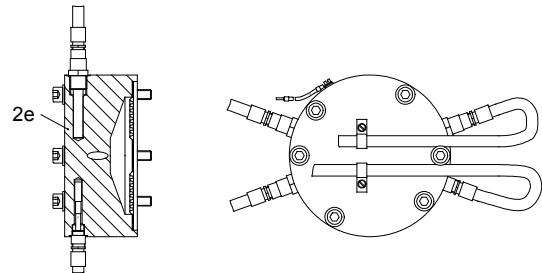

TM03 6460 4506

Fig. 22 Electrically heated dosing head

Pos.	Component
2e	Dosing head, electrically heated

- To connect the temperature controller to the power supply, see the installation and operating instructions for the electric temperature controller.

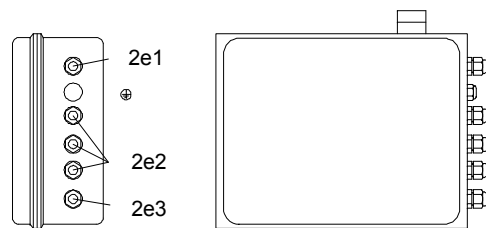

TM03 6461 4506

Fig. 23 Temperature controller

Pos.	Connections
2e1	Sensor
2e2	Heating
2e3	Power supply

## 7.4 Diaphragm controller (optional)



### Warning

Explosion-proof pumps with diaphragm leakage detection are fitted with a contact pressure gauge in explosion-proof version.

The pressure gauge must be earthed.

Connecting the earth cable (4u), see fig. 24.

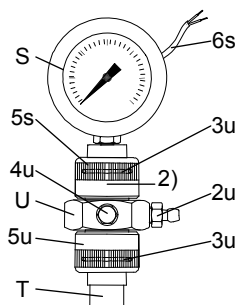

TM03 6453 4506

Fig. 24 Diaphragm controller

Pos.	Components
S	Contact pressure gauge
5s	Union nut
6s	Contact output
T	Ball non-return valve
U	Connection piece
2u	Deaeration screw
3u	O-rings
4u	Connection for earth cable
5u	Union nut
2)	or locking unit (instead of contact pressure gauge and its connection)

## 7.5 Connecting the power supply cable



### Warning

Disconnect the power supply before connecting the power supply cable!

Before connecting the power supply cable, check that the rated voltage stated on the pump nameplate corresponds to the local conditions!

Do not make any changes to the power supply cable or plug!

### Caution

The assignment between the plug-and-socket connection and the pump must be labelled clearly (e.g. by labelling the socket outlet).

### Caution

The pump can be automatically started by connecting the power supply!

- Do not switch on the power supply until you are ready to start the pump.

### 7.5.1 Versions with mains plug

- Insert the mains plug in the mains socket.

## 7.5.2 Versions without mains plug



### Warning

The pump must be connected to an external clearly labelled mains switch with a minimum contact gap of 3 mm in all poles.

- Connect the motor to the power supply in accordance with local electrical installation regulations and the connection chart on the terminal box cover.



### Warning

The specified enclosure class can only be ensured if the power supply cable is connected with the same degree of protection.

Observe the direction of rotation!

### Caution

To protect the motor, install a motor protecting switch or motor contactor, and set the bimetal relay to the rated motor current for the available voltage and frequency.

## 8. Start-up/shutdown

### 8.1 Initial start-up/subsequent start-up

### Warning

When dosing dangerous media, observe the corresponding safety precautions!

Wear protective clothing (gloves and goggles) when working on the dosing head, connections or lines!



Before removing the dosing head, valves and lines, empty any remaining medium in the dosing head into a drip tray by carefully unscrewing the suction valve.

The pump housing must only be opened by personnel authorised by Grundfos!

Repairs must only be carried out by authorised and qualified personnel!

### Caution

Observe the flow direction of valves (indicated by an arrow on the valve)!

### 8.1.1 Checks before start-up

- Check that the rated voltage stated on the pump nameplate corresponds to the local conditions!
- Check that all connections are secure and tighten, if necessary.
- Check that the dosing head screws are tightened with the specified torque and tighten, if necessary.
- Check that all electrical connections are correct.
- Cross-tighten the dosing head screws using a torque wrench.

### Torques

Pump type	Torque [Nm]
DMH 280	55-60
DMH 281	17-19
DMH 283	27-30
DMH 285	50-54
DMH 286	80-85
DMH 287	50-54
DMH 288	75-80

8.1.2 Oil filling

**The pump is factory-checked, and the oil is drained for shipping purposes. Before start-up, add the special oil supplied with the pump.**

**Note** *The piston flange is filled with oil for easy start-up. The stroke-length adjustment knob must only be adjusted if the gear oil has been added, otherwise the oil will leak from the piston flange.*

1. Slacken and remove the oil-filling screw (F).
2. Slowly add the hydraulic oil supplied with the pump through the oil-filling opening (F) until the oil reaches the mark on the oil dipstick.
3. Set the stroke-length adjustment knob (L) to "0".

8.1.3 Filling the dosing head for the initial start-up for systems without flooded suction (DMH 281-288)

**Warning**



**When dosing dangerous media, observe the corresponding safety precautions! Wear protective clothing (gloves and goggles) when working on the dosing head, connections or lines!**

As assisting suction for systems without flooded suction, you can fill the dosing head with dosing medium before the initial start-up:

1. Unscrew the discharge valve (3b).
2. Add the dosing medium to the dosing head (2).
3. Screw the discharge valve (3b) back in.

**Note** *Observe the flow direction of the discharge valve (indicated by an arrow on the valve)!*

8.2 Start-up/subsequent start-up of DMH 280

Fill the dosing head for start-up/subsequent start-up, see section *Filling the dosing head*. If the pump does not start, deaerate the piston flange, see *Deaerating the piston flange*.

Filling the dosing head

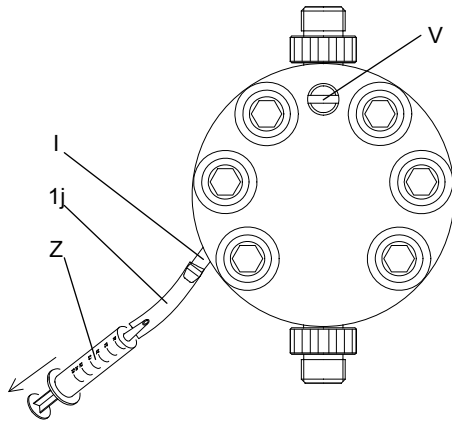

Fig. 25 Filling the dosing head

Pos.	Components
1j	Hose
I	Deaeration nipple
V	Deaeration screw
Z	Syringe

1. Loosen the dosing head deaeration screw (V) by approx. 1 turn.
2. Fit the hose (1j) supplied with the pump onto the deaeration nipple (I).
3. Using the syringe (Z) supplied with the pump, carefully draw the dosing medium until there is some liquid in the hose.
4. Tighten the deaeration screw (V).
5. Remove the hose (1j) and the syringe (Z).
6. Set the stroke-length adjustment knob to 70 % and let the pump run for approx. 5 minutes.
7. Switch off the pump, check the oil level and add oil, if necessary.
8. Refit the oil filling screw (F).
9. If already dosing, the pump is now ready for operation. If the pump is not dosing, deaerate the piston flange.

Deaerating the piston flange

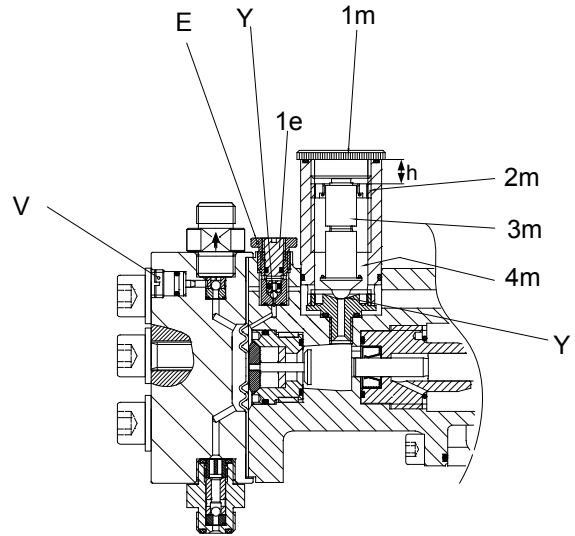

Fig. 26 Deaerating the piston flange

Pos.	Components
1q	Dosing head screws
2	Dosing head
3b	Discharge valve
F	Oil-filling screw with dipstick
L	Stroke-length adjustment knob
1l	Cover for stroke-length adjustment knob
M	Pressure relief valve
V	Deaeration screw
I	Hose nipple (connection for J)
J	Deaeration hose (not supplied with the pump)
1m	Cover for pressure relief valve
2m	Adjusting screw
3m	Pressure relief valve
4m	Spring
E	Degassing valve (cartridge)
1e	Adjusting screw
Y	Holes

TM03 6864 4506

TM03 6863 4506



1. Unscrew the cover for the pressure relief valve (1m).
2. Measure the adjustment depth (h) of the adjusting screw (2m).
3. Unscrew the adjusting screw (2m).
4. Remove the pressure relief valve (3m) with spring (4m).
5. Unscrew the whole degassing valve (cartridge) (E) using a fork wrench, size 14.

**Caution** Do not turn the inner slotted screw (adjusting screw (1e)), as this changes the degassing valve setting.

6. Connect the electrical power supply.
7. Let the pump run for approx. 5 minutes at a stroke setting of 0 % until oil (without bubbles) appears around the holes (Y). Add oil, if necessary.
8. Switch off the pump and screw in the degassing valve (E) with front side O-ring.
9. Refit the pressure relief valve (M/2m, 3m, 4m) in reverse order. Set the adjusting screw to the depth (h) already measured.
10. Set the stroke-length adjustment knob to 70 % and let the pump run for approx. 5 minutes.

The pump is now ready for operation.

#### Checking the degassing valve (cartridge)

**Note** The degassing valve (E) only operates with the spring (5e), ball (6e) and correct position of the adjusting screw (7e).

Check the setting of the degassing cartridge when the pump is switched off:

- Fully tighten the adjusting screw (7e) and then loosen by approx. 1/4 turn!

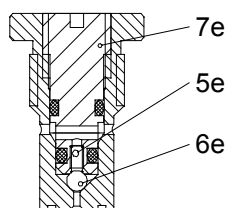

Fig. 27 Degassing valve

Pos.	Components
5e	Spring
6e	Ball
7e	Adjusting screw

**Note** Rod length of oil dipstick: 27 mm.  
Immersion depth to marking: approx. 5 mm.

Check the oil level at least every two weeks and add oil, if necessary.

**Note** Only use original Grundfos gear oil!  
For product numbers, see "Service kit catalogue" on [www.grundfos.com](http://www.grundfos.com)

Pump type	Version	Description
DMH 280	Single/double	1.3 I DHG 68

#### After start-up

After initial start-up and after each time the diaphragm is changed, tighten the dosing head screws.

**Caution** After approximately 6-10 operating hours or two days, cross-tighten the dosing head screws using a torque wrench.

#### Torques

Pump type	Torque [Nm]
DMH 280	55-60

### 8.3 Start-up/subsequent start-up of DMH 281-288

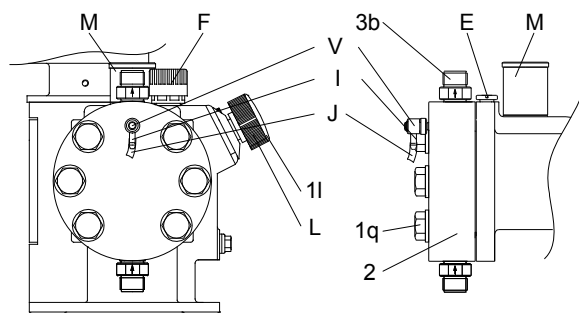

Fig. 28 Start-up of DMH 281-288

Pos.	Components
1q	Dosing head screws
2	Dosing head
3b	Discharge valve
E	Degassing valve
F	Oil-filling screw with dipstick
L	Stroke-length adjustment knob
1l	Cover for stroke-length adjustment knob
M	Pressure relief valve
V	Deaeration screw
I	Hose nipple (connection for J)
J	Deaeration hose (not supplied with the pump)

1. Connect the electrical power supply.
2. Set the stroke-length adjustment knob (L) to 0 %.
3. Let the pump run for approx. 5 minutes.

#### Deaerating the dosing head

1. Loosen the deaeration screw (V) by 1 turn to the left.
2. Turn the hose nipple (I) vertically downwards.

#### Warning

**Risk of injuries caused by the dosing medium. Dosing medium leaks from the hose nipple (I) of the deaeration line. If the pressure is high, the medium may squirt out. Turn the hose nipple (I) in the right direction, or drain the dosing medium through a suitable hose.**



**When dosing dangerous media, observe the corresponding safety precautions!**

**Wear protective clothing (gloves and goggles) when working on the dosing head, connections or lines!**

3. Set the stroke-length adjustment knob (L) to 15 %.
4. Let the pump run until the dosing medium flows from the deaeration hose (J) or hose nipple (I) without any bubbles back into the tank.
5. Tighten the deaeration screw (V).

TM03 6866 4506

TM03 6865 4506

**Checking the oil level**

1. Set the stroke-length adjustment knob (L) to 40 %.
2. Let the pump run for approx. 10 minutes with a stroke-length setting of 40 %.
3. Switch off the pump, check the oil level and add oil, if necessary.
4. Refit the oil-filling screw (F).

The pump is now ready for operation.

**Rod length of oil dipstick:**

**Note** 35 mm (27 mm for DMH 281).

**Immersion depth to marking: approx. 5 mm.**

**Check the oil level at least every two weeks and add oil, if necessary.**

**Note** Only use original Grundfos gear oil!

For product numbers, see "Service kit catalogue" on [www.grundfos.com](http://www.grundfos.com)

Pump type	Version	Description
DMH 281	Single	1.3 l DHG 68
DMH 281	Double	1.3 l DHG 68
DMH 283	Single	3.5 l DHG 68
DMH 283	Double	4.5 l DHG 68
DMH 285	Single	5.5 l DHG 68
DMH 285	Double	7.5 l DHG 68
DMH 286	Single	5.5 l DHG 68
DMH 286	Double	7.5 l DHG 68
DMH 287	Single	5.5 l DHG 68
DMH 287	Double	7.5 l DHG 68
DMH 288	Single	3.5 l DHG 68
DMH 288	Double	4.5 l DHG 68

**After start-up**

After initial start-up and after each time the diaphragm is changed, tighten the dosing head screws.

**Caution**

After approximately 6-10 operating hours or two days, cross-tighten the dosing head screws using a torque wrench.

**Torques**

Pump type	Torque [Nm]
DMH 281	17-19
DMH 283	27-30
DMH 285	50-54
DMH 286	80-85
DMH 287	50-54
DMH 288	75-80

**8.4 Setting the pressure relief valve**

The pressure relief valve is set to the pressure given by the customer, or to the rated pressure (maximum counter-pressure). The opening pressure can be set to a lower value by the customer.

**Opening pressure of the pressure relief valve**

Rated pressure of the pump [bar]	Opening pressure of the pressure relief valve [bar]
50	55
100	110
200	210

**Setting the opening pressure**

- To set the operating pressure, a pressure gauge must be installed in the discharge line and an isolating valve must be installed after the pressure gauge.
- To set the pressure relief valve,
  - use a screwdriver for DMH 280.
  - use a special tool for DMH 281-288.

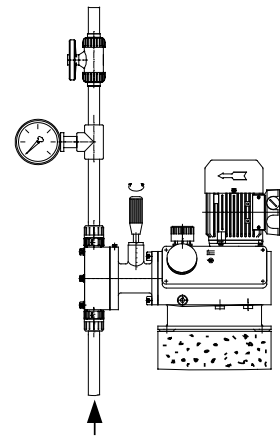

**Fig. 29** Setting the opening pressure

Set the pressure relief valve as follows:

1. Close the isolating valve after the pressure gauge.
2. Remove the cover (1m) from the pressure relief valve.
3. Start the pump.
4. Adjust the pressure relief valve.
  - **DMH 280:** Using a screwdriver, slowly turn the adjusting screw (2m) of the pressure relief valve clockwise until the desired opening pressure is obtained.
  - **DMH 281-288:** Using the special tool, slowly turn the adjusting nut (2m) of the pressure relief valve clockwise until the desired opening pressure is obtained.

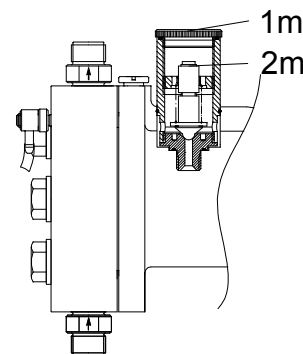

**Fig. 30** Setting the pressure relief valve

TM03 6464 1612

TM03 6465 4506

**Risk of damage to the pump or system!**

**When blocked, the pressure relief valve does not work properly and can produce pressures of several hundred bar in the pump or system. Do not block the pressure relief valve during adjustments!**

**Caution**

- Replace the cover of the pressure relief valve.
- Open the isolating valve after the pressure gauge.

**8.5 Zero point adjustments (DMH 281-288)****8.5.1 Adjusting the zero point for system pressures up to 100 bar**

The zero point of the dosing pump is factory-set to a slightly lower counter-pressure than the rated pressure of the pump. If the operating counter-pressure deviates considerably from this value, an adjustment of the zero point will ensure more precise values.

**Counter-pressure at the factory-set zero point of the pump**

Rated pressure of the pump [bar]	Counter-pressure at the factory-set zero point [bar]
50	30
100	80

**8.5.2 Adjusting the zero point for system pressures of 100 bar and up**

**The pump cannot run if the stroke-length adjustment knob is fully open. Depending on the pump adjustment, this value may already be lower than 100 % on the scale for system pressures of 100 bar and up.**

**Caution****Adjusting range approx. 20-100 %**

If the rated pressure of the pump is 100 bar or higher, the maximum dosing flow is factory-adjusted to a scale value of 100 %. The zero point is not set. The zero dosing flow is reached depending on the system pressure, e.g. already at 20 % on the scale.

**Adjusting range approx. 0-80 %**

You can make an adjustment so that the zero dosing flow is at a scale value of zero, but the non-permissible operating range is then within the 100 % of the scale value! Loosen the stroke-length adjustment knob completely for a maximum dosing flow, and then close it by approx. 10 %.

**Counter-pressure at the factory-set zero point of the pump**

Rated pressure of the pump [bar]	Counter-pressure at the factory-set maximum point [bar]
200	160

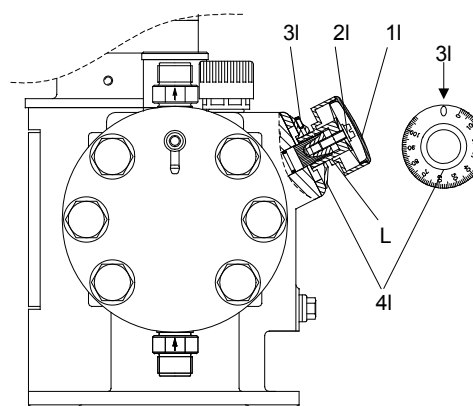
**8.5.3 Adjusting the zero point****Fig. 31** Adjusting the zero point

TM03 6466 4506

**Pos. Components**

L	Stroke-length adjustment knob
1l	Cover
2l	Locking screw
3l	Screw
4l	Scale ring

**Warning**

**When dosing dangerous media, observe the corresponding safety precautions!**

**Wear protective clothing (gloves and goggles) when working on the dosing head, connections or lines!**

**Always adjust the value with the discharge line connected and with operating counter-pressure.**



- Fit a measuring device on the suction side, for instance place the suction line in a graduated measuring beaker.
- Set the dosing flow to 15 %.
- Remove the cover (1l) from the stroke-length adjustment knob (L).
- Use a screwdriver to loosen the locking screw (2l) by approximately 2 turns.
- Switch on the pump.
- Slowly turn the stroke-length adjustment knob towards the zero point until the dosing (the liquid level falls) stops in the measuring device.
- Switch off the pump.
- Set the scale ring (4l) to zero.
  - Loosen the screw (3l) in the scale ring (4l) slightly using an hexagon key, M3.
  - Turn the scale ring (4l) until both "0" are the same on the scale and scale ring.
  - Tighten the screw (3l).
- Depending on the application, tighten the locking screw (2l) so that the stroke-length adjustment knob can still be turned/cannot be turned any more.
- Replace the cover (1l).

**8.6 Operating the pump****Note**

**When operating the pump, see sections 9. Operation and 10. Maintenance and, if necessary, section 11. Fault finding chart.**

## 8.7 Shutdown

### Warning



**Wear protective clothing (gloves and goggles) when working on the dosing head, connections or lines!**

**Do not allow any chemicals to leak from the pump. Collect and dispose of all chemicals correctly!**

### Note

**If possible, rinse the dosing head before shutting down the pump, e.g. by supplying it with water.**

### 8.7.1 Switching off/uninstalling

1. Switch off the pump and disconnect it from the power supply.
2. Depressurise the system.
3. Take suitable steps to ensure that the returning dosing medium is safely collected.
4. Carefully remove all lines.
5. Uninstall the pump.

### 8.7.2 Cleaning

1. Rinse all parts that have come into contact with the medium very carefully:
  - lines
  - valves
  - dosing head
  - diaphragm.
2. Remove any trace of chemicals from the pump housing.

### 8.7.3 Storage

Storage of the pump:

1. After cleaning (see section 8.7.2 *Cleaning*), carefully dry all parts and reinstall the dosing head and valves, or
2. change the valves and diaphragm.

See section 10. *Maintenance*.

### 8.7.4 Disposal

Disposal of the pump:

- After cleaning (see section 8.7.2 *Cleaning*), dispose of the pump in accordance with the relevant regulations.

## 9. Operation

### 9.1 Switching on/off

#### Caution

**Before switching on the pump, check that it is installed correctly. See sections 6. *Installation* and 8. *Start-up/shutdown*.**

- To start the pump, switch on the power supply.
- To stop the pump, switch off the power supply.

### 9.2 Setting the dosing capacity

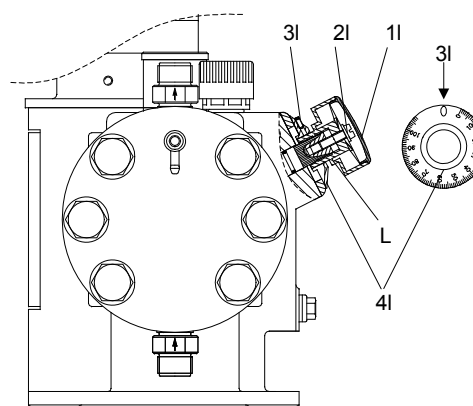

**Fig. 32** Setting the dosing capacity

Pos.	Components
L	Stroke-length adjustment knob
1l	Cover
2l	Locking screw
3l	Screw
4l	Scale ring

#### 9.2.1 Setting the dosing flow and locking the stroke-length adjustment knob

1. Remove the cover (1l) from the stroke-length adjustment knob (L).
2. Use a screwdriver to loosen the locking screw (2l) by approximately 2 turns.
3. Increase or *reduce* the dosing flow while the pump is running.
  - Slowly turn the stroke-length adjustment knob to the left or *right* to set the desired dosing volume.
4. Depending on the application, tighten the locking screw (2l) so that the stroke-length adjustment knob can still be turned/cannot be turned any more.
5. Replace the cover (1l).

**The pump cannot be operated if the stroke-length adjustment knob is fully open! Depending on the pump adjustment, this value may already be lower than 100 % on the scale for system pressures higher than 100 bar.**

#### Caution

**Open the stroke-length adjustment knob completely and then close by approx. 10 % in order to set the dosing flow to 100 %.**

TMO3 6466 4506

### 9.3 Deaeration

Manual deaeration of the dosing head (while the pump is running)



**Warning**

When dosing dangerous media, observe the corresponding safety precautions! Wear protective clothing (gloves and goggles) when working on the dosing head, connections or lines!



**Warning**

Risk of injuries caused by the dosing medium. Dosing medium leaks from the hose nipple (I) of the deaeration line. If the pressure is high, the medium may squirt out. Turn the hose nipple (I) in the right direction, or drain the dosing medium through a suitable hose.

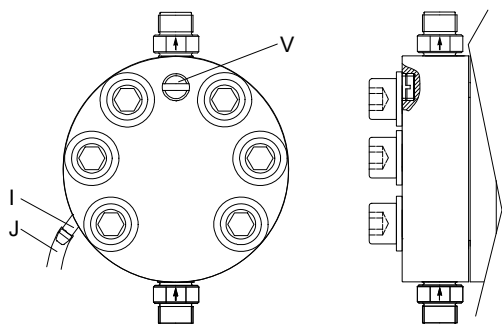

Fig. 33 DMH 280

TM03 6867 4506

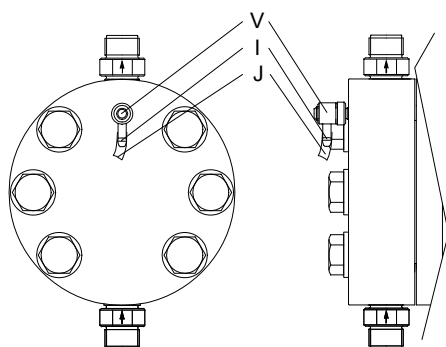

Fig. 34 DMH 281-288

TM03 6868 4506

Pos.	Components
I	Hose nipple
J	Deaeration hose
V	Deaeration screw

**Note** DMH 280: If the deaeration screw is too loose, the O-ring can be washed away.

- Loosen the deaeration screw (V):
  - DMH 280: by max. 1/2 turn to the left.
  - DMH 281-288: by 1 turn to the left.
- Let the pump run until the dosing medium flows from the deaeration hose (J) or hose nipple (I) without any bubbles back into the tank.
- Carefully tighten the deaeration screw (V).

### 9.4 Using the AR control unit (optional)

When using the AR control unit, observe the installation and operating instructions for the "AR control unit" in addition to the instructions in this manual.

### 9.5 Electric servomotor (optional)

To operate the servomotor, see the installation and operating instructions for the servomotor.

### 9.6 Electronic preselection counter (optional)

To operate the preselection counter, see the installation and operating instructions for the counter.

### 9.7 Electrically heated dosing head (optional)

To operate the temperature controller, see the installation and operating instructions for the temperature controller.

## 10. Maintenance

### 10.1 General notes

**Warning**

When dosing dangerous media, observe the corresponding safety precautions! Wear protective clothing (gloves and goggles) when working on the dosing head, connections or lines!



The pump housing must only be opened by personnel authorised by Grundfos! Repairs must only be carried out by authorised and qualified personnel!

Switch off the pump and disconnect it from the power supply before carrying out maintenance work and repairs!

Before removing the dosing head, valves and lines, empty any remaining medium in the dosing head into a drip tray by carefully unscrewing the suction valve.

**Caution** Observe the flow direction of valves (indicated by an arrow on the valve)!

### 10.2 Diaphragm leakage control for diaphragm leakage detection

If a diaphragm leakage has been detected, first of all check whether an error has been displayed, as different external factors such as the heating of dosing or hydraulic medium can cause the cracked medium between the diaphragms to be displaced into the valve, thereby causing an error to occur.

Checks after a diaphragm leakage detection:

- Briefly open the deaeration screw (2u) and then close it again.
- Switch on the pump.
- If, after a short period of time, a diaphragm leakage is detected again, a diaphragm has broken.

**Caution** After a diaphragm breakage, replace the diaphragms and clean the non-return valve, see section 10.7 Replacing the diaphragm for dosing head with double diaphragm.

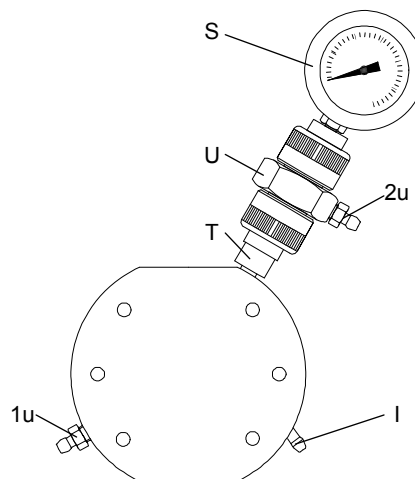
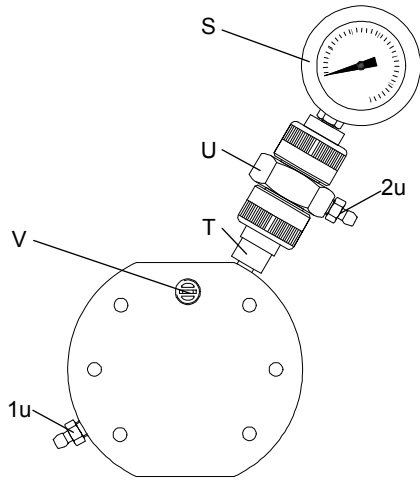

Fig. 35 DMH 280: dosing head with double diaphragm

TM03 6869 4506



TM03 6870 4506

Fig. 36 DMH 281-288: dosing head with double diaphragm

Pos.	Components
I	Connection for deaeration line
S	Contact pressure gauge
T	Ball non-return valve
U	Connection piece
1u	Filling screw
2u	Deaeration screw
V	Deaeration screw

### 10.3 Cleaning and maintenance intervals

#### Checking the oil level

- Check the oil level every two weeks and add oil, if necessary.

#### Cleaning the valves

- At least every 12 months or after 4,000 operating hours.
- If the pump does not perform.
- In the event of a fault.

Clean the valves and replace, if necessary (for stainless-steel valves: inner valve parts).

#### Changing diaphragms and gear oil

- At least every 12 months or after 8,000 operating hours, change the dosing medium and gear oil.
- In dusty installation sites, change the gear oil every 3,000 operating hours.

#### Cleaning the ball non-return valve of the double diaphragm

- After a diaphragm breakage, remove the ball non-return valve immediately and clean it.

**Note** Only clean the ball non-return valve after a diaphragm breakage!

#### Replacing the grooved ring

- In the event of a fault, e.g. pump not performing, the grooved ring can be checked by authorised personnel and replaced, if necessary.

### 10.4 Checking the oil level

**Caution** Check the oil level at least every two weeks and add oil, if necessary.

**Rod length of oil dipstick:**

**Note** DMH 280-281: 27 mm.

DMH 283-288: 35 mm.

Immersion depth to marking: approx. 5 mm.

### 10.5 Cleaning the suction and discharge valves

**Warning**  
 Wear protective clothing (gloves and goggles) when working on the dosing head, connections or lines!  
 Before removing the dosing head, valves and lines, empty any remaining medium in the dosing head into a drip tray by carefully unscrewing the suction valve.



#### DN 4 valve

- Screwed connection 3/8"
- Stainless steel
- Spring-loaded.

#### DN 8 valve

- Screwed connection 5/8"
- Stainless steel
- Spring-loaded.

#### DN 20 valve

- Screwed connection 1 1/4"
- Stainless steel
- Spring-loaded (optional).

Clean the suction and discharge valves as follows:

1. Unscrew the valves.
2. Unscrew the screw parts and valve set using round pliers.
3. Dismantle the inner part (seat, O-ring, balls, ball cages and, if present, spring).
4. Clean all parts. Replace faulty parts by new ones.
5. Re-assemble the valve.
6. Replace the O-rings by new ones. Refit the valve.

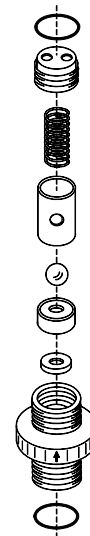

Fig. 37 Stainless steel DN 4 valve, spring-loaded

TM03 6871 4506

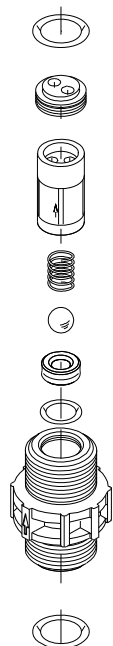

Fig. 38 Stainless-steel DN 8 valve, spring-loaded

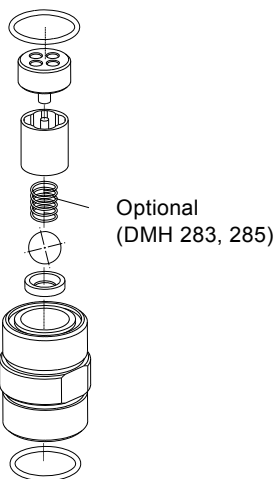

Fig. 39 Stainless-steel DN 20 valve

**Caution** *The O-rings must be correctly placed in the specified groove. Observe the flow direction (indicated by an arrow on the valve)!*

TM03 6468 4506

TM04 8569 2812

### 10.6 Replacing the diaphragm and gear oil for dosing head with single diaphragm (no diaphragm leakage detection)

**Warning**

*Wear protective clothing (gloves and goggles) when working on the dosing head, connections or lines!*



*The dosing diaphragm should be replaced with each gear oil change.*

*Before removing the dosing head, valves and lines, empty any remaining medium in the dosing head into a drip tray by carefully unscrewing the suction valve.*

*Only use original Grundfos gear oil!*

**Note** *For product numbers, see "Service kit catalogue" on [www.grundfos.com](http://www.grundfos.com)*

Pump type	Version	Description
DMH 280	Single/double	1.3 l DHG 68
DMH 281	Single/double	1.3 l DHG 68
DMH 283	Single	3.5 l DHG 68
DMH 283	Double	4.5 l DHG 68
DMH 285	Single	5.5 l DHG 68
DMH 285	Double	7.5 l DHG 68
DMH 286	Single	5.5 l DHG 68
DMH 286	Double	7.5 l DHG 68
DMH 287	Single	5.5 l DHG 68
DMH 287	Double	7.5 l DHG 68
DMH 288	Single	3.5 l DHG 68
DMH 288	Double	4.5 l DHG 68

**Note** *Collect the gear oil in a container and dispose of it correctly.*

#### 10.6.1 Drain gear oil

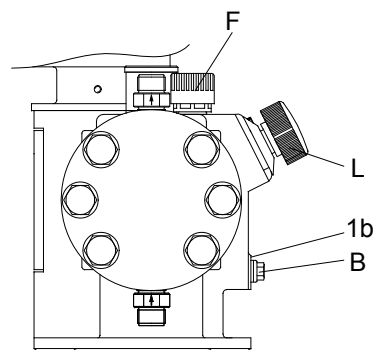

Fig. 40 Drain gear oil

Pos.	Components
B	Locking screw
1b	Gasket
F	Oil-filling screw with dipstick
L	Stroke-length adjustment knob

1. Unscrew the locking screw (B) and collect the gear oil in a container.
2. Screw the locking screw (B) and the new gasket (1b) back in and tighten securely.

**Caution** *Risk of leaking oil and damage caused by oil loss! For each oil change, a new flat gasket (1b) must be fitted!*

TM03 6472 4506

**10.6.2 Removing the dosing head**

1. Close the suction and discharge lines and loosen the suction and discharge valve connections.
2. Loosen the six dosing head screws (1q with 2q).
3. Remove the dosing head (2).

**10.6.3 Replacing a single diaphragm (no diaphragm leakage detection)**

- Remove the diaphragm and fit a new diaphragm (Q) on the suction side. See fig. 41.

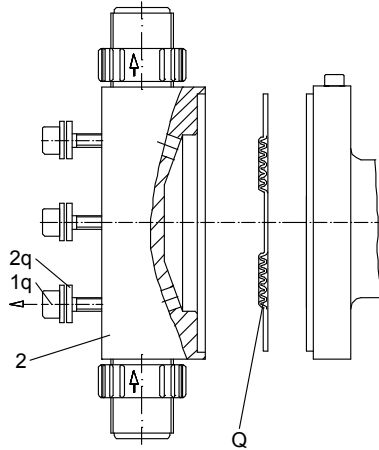

TMO3 6473 4506

**Fig. 41** Replacing a single diaphragm

Pos.	Components
1q	Dosing head screw
2q	Intermediate disk
2	Dosing head
Q	Diaphragm

**10.6.4 Fitting the dosing head**

- Fit the dosing head and cross-tighten the dosing head screws (1q with 2q) using a torque wrench.

**Note** See section 8. Start-up/shutdown for subsequent start-up!

**10.6.5 Filling with gear oil**

**Risk of leaking oil and damage caused by oil loss!**  
**For each oil change, a new flat gasket (1b) must be fitted!**

- Caution**

  1. Check that the locking screw (B) is tightened.
  2. Slacken and remove the oil-filling screw (F).
  3. Set the stroke-length adjustment knob (L) to "0".
  4. Slowly add the hydraulic oil through the oil-filling opening (F) until the oil reaches the mark on the oil dipstick.
  5. Wait 30 minutes.
  6. Let the pump run for approx. 5 minutes with a stroke-length setting of 0 %.
  7. Let the pump run for approx. 10 minutes with a stroke-length setting of 40 %.

**10.6.6 Checking the oil level**

1. Switch off the pump, check the oil level and add oil, if necessary.
2. Refit the oil-filling screw (F).

**After initial start-up and after each time the diaphragm is changed, tighten the dosing head screws.**

**Caution** After approximately 6-10 operating hours or two days, cross-tighten the dosing head screws using a torque wrench.

**Torques**

Pump type	Torque [Nm]
DMH 280	55-60
DMH 281	17-19
DMH 283	27-30
DMH 285	50-54
DMH 286	80-85
DMH 287	50-54
DMH 288	75-80

**10.7 Replacing the diaphragm for dosing head with double diaphragm**

**Warning**

**Wear protective clothing (gloves and goggles) when working on the dosing head, connections or lines!**



**The dosing diaphragm should be replaced with each gear oil change.**

**Before removing the dosing head, valves and lines, empty any remaining medium in the dosing head into a drip tray by carefully unscrewing the suction valve.**

**Only use original Grundfos gear oil!**

**Note** For product numbers, see "Service kit catalogue" on [www.grundfos.com](http://www.grundfos.com)

**10.7.1 Removing the dosing head**

1. Close the suction and discharge lines and loosen the suction and discharge valve connections.
2. Loosen the six dosing head screws (1q with 2q).
3. Remove the dosing head (2).

**10.7.2 Replacing a double diaphragm**

1. Clean the intermediate disk (3q), sealing rings (4q) and covering rings (5q). After a diaphragm breakage, replace the parts by new ones.
2. Remove both clamping sleeves (6q) slightly using pliers. After a diaphragm breakage, replace the parts by new ones.
3. Measure the outer wall thickness of both new diaphragms (Q1 and Q2):  $s_{1(Q1)} < s_{2(Q2)}$ .



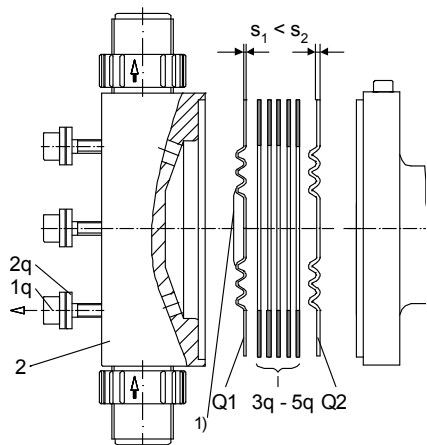

TM03 6474 4506

Fig. 42 Installation of diaphragm

1) The shape of the diaphragm varies depending on pump type.

Pos.	Components
1q	Dosing head screw
2q	Intermediate disk
2	Dosing head
Q1/Q2	See fig. 43
3q - 5q	

Observe correct installation of diaphragms (Q1 and Q2)! See fig. 43.

**Caution** Fit the thinner diaphragm (Q1) on the dosing side and the thicker diaphragm (Q2) on the oil side/pump side!

4. Fit both new diaphragms (Q1 and Q2) and the parts (3q - 5q) in the correct order, as is shown in the diagrams (the clamping sleeves (6q) are used for centring purposes).

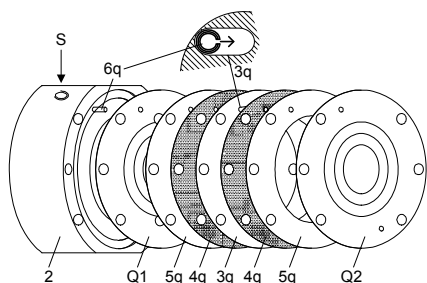

TM03 6475 4506

Fig. 43 Diaphragm on dosing-head side

Pos.	Components
S	Contact pressure gauge (installation position)
Q1	Diaphragm on dosing-head side
Q2	Diaphragm on oil side/pump side
3q	Intermediate disk
4q	Sealing rings
5q	Covering rings
6q	Clamping sleeves

The paraffin oil between the diaphragms (Q) is connected via the clamping sleeves (6q) to the contact pressure gauge (S) in order to fill and activate the diaphragm leakage detection.

The oil is able to pass between the diaphragms through the slits in the clamping sleeves and the slits in the intermediate disk.

The clamping sleeves (6q) must therefore be installed in such a way that the slits in the clamping sleeve face the slits in the intermediate disk (3q). See fig. 43.

**Caution**

### 10.7.3 Fitting the dosing head

- Fit the dosing head and cross-tighten the dosing head screws using a torque wrench.

**Note**

See section 8. Start-up/shutdown for subsequent start-up!

### 10.7.4 Filling the double diaphragm with separating agent

After a diaphragm has broken, the ball non-return valve must be cleaned before the diaphragm is filled with separating agent. Only clean the ball non-return valve after a diaphragm breakage!

**Caution**

Pump with double diaphragm: After the diaphragm has been replaced, refill the separating agent between the diaphragms.

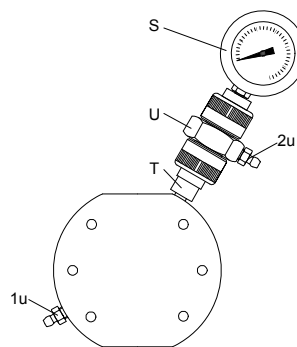

TM03 6467 4506

Fig. 44 Dosing head with double diaphragm

Pos.	Components
S	Contact pressure gauge
T	Ball non-return valve
U	Connection piece
1u	Filling screw
2u	Deaeration screw

- Set the stroke-length adjustment knob of the pump to 0 %.
- Open the filling screw (1u) and deaeration screw (2u) by one turn.
- Connect the filling hose to the nipple of the filling screw (1u) and, using the dosing syringe, inject the correct amount of paraffin oil that is specified in the table below.
- Close the filling screw (1u), but leave the deaeration screw (2u) open.
- Start the pump with a system counter-pressure and stroke-length setting of 40 %.
- Only close the deaeration screw (2u) when the separating agent stops flowing (after 5 to 10 minutes).

**Note**

After a few operating hours, especially if the pressure of the pressure gauge is increasing, deaerate the double diaphragm again.

Quantity of paraffin oil required for dosing pumps with a double diaphragm (per dosing head)

Pump type	Filling quantity [ml]
DMH 280	3
DMH 281	3

Pump type	Filling quantity [ml]
DMH 283	4
DMH 285	4
DMH 286	6
DMH 287	4
DMH 288	4

**Note** For product numbers of double-diaphragm filling components, see "Service kit catalogue" on [www.grundfos.com](http://www.grundfos.com)

**10.7.5 Filling with gear oil**

**Risk of leaking oil and damage caused by oil loss!**

**Caution** For each oil change, a new flat gasket (1b) must be fitted!

1. Check that the locking screw (B) is tightened.
2. Slacken and remove the oil-filling screw (F).
3. Set the stroke-length adjustment knob (L) to "0".
4. Slowly add the hydraulic oil through the oil-filling opening (F) until the oil reaches the mark on the oil dipstick.
5. Wait 30 minutes.
6. Let the pump run for approx. 5 minutes with a stroke-length setting of 0 %.
7. Let the pump run for approx. 10 minutes with a stroke-length setting of 40 %.

**10.7.6 Checking the oil level**

1. Switch off the pump, check the oil level and add oil, if necessary.
2. Refit the oil-filling screw (F).

**After initial start-up and after each time the diaphragm is changed, tighten the dosing head screws.**

**Caution** After approximately 6-10 operating hours or two days, cross-tighten the dosing head screws using a torque wrench.

**Torques**

Pump type	Torque [Nm]
DMH 280	55-60
DMH 281	17-19
DMH 283	27-30
DMH 285	50-54
DMH 286	80-85
DMH 287	50-54
DMH 288	75-80

**10.7.7 Cleaning the ball non-return valve**

**Note** Only clean the ball non-return valve after a diaphragm breakage!

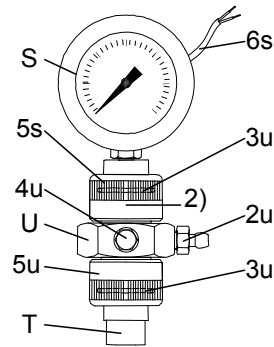

**Fig. 45** Contact pressure gauge

Pos.	Components
S	Contact pressure gauge
5s	Union nut
6s	Contact output
T	Ball non-return valve
U	Connection piece
2u	Deaeration screw
3u	O-rings
4u	Connection for earth cable
5u	Union nut
2)	or locking unit (instead of contact pressure gauge and its connection)

**Removing the ball non-return valve and contact pressure gauge**

1. For pumps and pressure gauges in explosion-proof version, unscrew the earth cable (4u).
2. Hold the connection piece (U) with a screwdriver and unscrew the union nut (5u).
3. Unscrew the ball non-return valve (T) from the dosing head.

TM03 6453 4506

## Cleaning the ball non-return valve

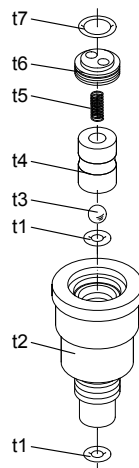

TMD3 6476 4506

**Fig. 46** Ball non-return valve

Pos.	Components
t1	O-ring
t2	Ball non-return valve body
t3	Ball
t4	Spring sheath
t5	Pressure spring
t6	Screw part
t7	O-ring

1. Unscrew the screw part (t6) using round pliers.
2. Clean all parts. Replace faulty parts by new ones.
3. Re-assemble the ball non-return valve.
4. Refit the ball non-return valve (T).
5. Screw the contact pressure gauge (S) and connection piece (U) back on.
6. For pumps and pressure gauges in explosion-proof version, screw the earth cable (4u) back on.

**Caution**

***Tighten the ball non-return valve and connection piece by hand only.***

## 11. Fault finding chart



### Warning

Actions that are taken to correct faults on the pump and that are not described in this manual, must only be carried out by personnel authorised by Grundfos!

Fault	Diagnosis	Cause	Remedy
No dosing flow even at a low counter-pressure. (Pump is running without any noise).	No motor sound or vibrations. Fan is not rotating.	Motor is not running.	Connect the power supply or replace the motor, if blown.
	When the oil-filling screw (F) is removed, use the dipstick to observe a calm oil surface. There is no "sloshing".	Motor runs, but the eccentric shaft is not rotating. No piston movement. Spiral pin or motor shaft broken.	Remove the motor and eccentric shaft. Replace damaged parts.
	The degassing valve (M) does not evacuate any oil. Oil level too low. See oil dipstick (F). No reaction of the overpressure valve if the suction line is closed.	Not enough oil in the pump. Air is penetrating the piston flange through the control holes.	Fill in oil. Deaerate the pump, see section 8. <i>Start-up/shutdown.</i>
	No dosing flow on the discharge side.	Dosing head is not filled. Suction line empty. Tank empty.	Deaerate the dosing head. Fill/exchange the tank on the suction side.
No dosing flow even at a low counter-pressure. (Pump is running noisily although the overpressure valve reacted).	The overpressure valve reacts independently of the dosing flow adjustment (10 % to 100 %). Fault detection: When the dosing head deaeration screw (V) is opened, jet medium leaks out.	Valve on discharge side closed.	Open the valve.
		Counter-pressure is higher than the adjusted pressure at the overpressure valve.	Adjust the overpressure valve higher, but only if the pump is designed for this. Never block the overpressure valve.
		Discharge valve is installed in the opposite direction of the flow. Observe the arrow on the valve.	Install the discharge valve correctly.
	The diaphragm protection system (AMS) responds. The overpressure valve reacts independently of the dosing flow adjustment (10 % to 100 %). Fault detection: When the dosing head deaeration screw (V) is opened, no jet medium leaks out.	Valve on suction side closed.	Open the valve.
		Suction filter obstructed.	Clean the suction filter. Replace, if necessary.
		Suction valve jammed (does not open).	Dismantle and check the suction valve.
		Suction valve has a too strong spring.	Use the fitting spring, or use double ball valve for checking.
		Suction valve is installed in the opposite direction of the flow. Observe the arrow on the valve.	Install the suction valve correctly.
	The diaphragm protection system (AMS) responds. The overpressure valve reacts at 100 % dosing flow. When reducing the flow ~10 % to 20 %, the overpressure valve does not react any more.	Dosing head is not completely deaerated.	Fill the dosing head completely.
		Pump is cavitating (dosing liquid with too high viscosity; dosing liquid with too high steam pressure at operating temperature = degassing of the liquid; suction lift too high; wrong design of the system on suction side).	Use a gear with a low stroke number; use valves with bigger nominal width; realise positive inlet pressure.
Diaphragm broken (not enough oil in the enclosure of the pump; piston flange).		Clean and grease well all parts using oil according to regulations. Then install a new diaphragm.	
Pump does not dose or pressure relief valve opens.		Discharge valve of pump is clogged or ball guide in the valve is worn due to corrosive or abrasive media.	Uninstall the discharge valve. Dismantle and clean, or if the bars of the ball guide are worn, replace the valve.

Fault	Diagnosis	Cause	Remedy
	Suction valve: During the discharge stroke, the dosing liquid flows back into the suction line. Discharge valve: During the suction stroke, the dosing liquid flows back into the dosing head. The pump takes in less.	Suction/discharge valves dirty or leaky.	Clean or replace valves.
	Dosing flow depends very much on the pressure. If the counter-pressure is low, the dosing flow increases considerably. If the stroke frequency rises, the dosing flow increases excessively.	The piston lip seal is worn out (usually after a long period of operation or if the oil is dirty). Too much clearance between piston and slide valve, or the stroke frequency of the pump is too low (too much slip).	Replace grooved ring. Replace the piston and piston slide valves. Use other hydraulic oil with a higher viscosity (mainly for frequency converter operation and higher counter-pressures).
Dosing flow too small.	Fault detection: When the pump stops, fit the degassing valve (E) block, start up the pump. Check if the dosing flow increases. Open the degassing valve (E) again when the pump stops.	The O-rings of the degassing valve (E) are faulty.	Replace O-rings. <b>Caution!</b> If the O-rings are incorrectly installed, or if the degassing valve (E) is adjusted during operation, this may damage the O-rings.
		The degassing valve (M) discharges too much oil.	Correct setting and replace degassing valve (M), if necessary.
	The degassing valves (M, E) no longer operate. The degassing valve (M) does not discharge any oil. Briefly close the suction side until the overpressure valve reacts. Adjust the dosing flow to approx. 50 %. The piston flange conveys the oil and the air into the tank via the overpressure valve. New oil is extracted from the tank and taken in through the piston holes.	Air has accumulated in the piston flange. The air cannot be evacuated.	Check setting on degassing valve (M), replace degassing valves (M, E), if necessary.
	Pressure gauge in discharge line.	Counter-pressure has seriously increased. Overpressure valve is adjusted too low.	Readjust the zero point (DMH 281-288). Correct the setting of the pressure relief valve.
Pump doses too much.	Pressure gauge in discharge line.	Counter-pressure has seriously dropped.	Readjust the zero point (DMH 281-288).
	Heavy overdose.	Inlet pressure of suction line higher than counter-pressure of discharge line.	Install a pressure-loading valve.
	Overdosing at high dosing flow settings and flows.	Too big dynamic in the suction line.	Install a pulsation damper on the suction side.

## 12. Dosing curves

The dosing curves on the following pages are trend curves.

They apply to:

- performance of single pump (the flow rate is doubled for the double pump)
- water as dosing medium
- zero point of pump  $Q_0$  for specified pressure, see table below
- standard pump version.

Abbreviation	Description
Q	Dosing flow
$Q_0$	Zero point of the pump
h	Stroke length

### DMH 280

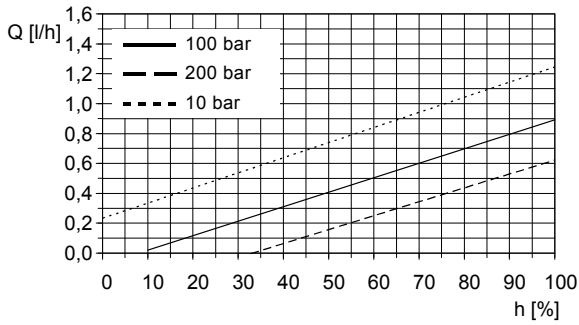

Fig. 47 DMH 0.6-200 (50 Hz),  $Q_0 = 75$  bar

TM03 6796 4506

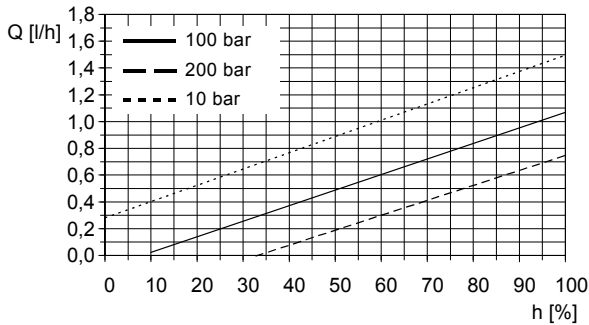

Fig. 48 DMH 0.6-200 (60 Hz),  $Q_0 = 75$  bar

TM03 6797 4506

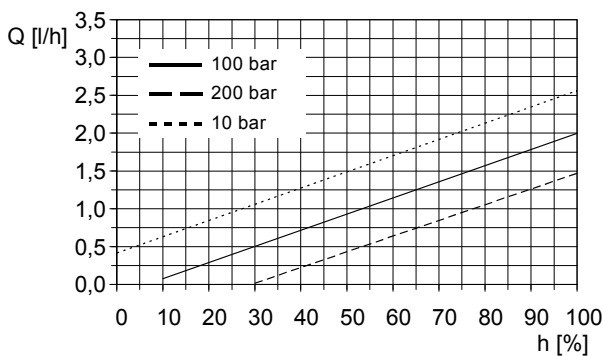

Fig. 49 DMH 1.3-200 (50 Hz),  $Q_0 = 75$  bar

TM03 6798 4506

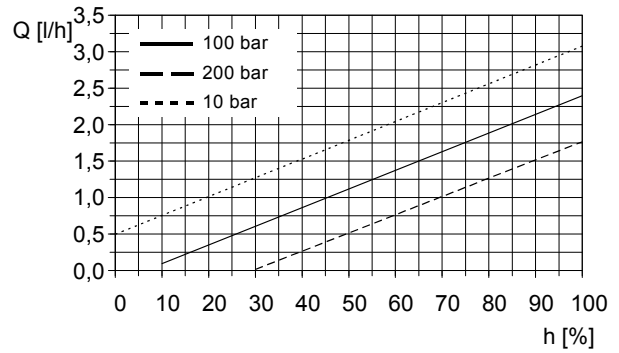

Fig. 50 DMH 1.3-200 (60 Hz),  $Q_0 = 75$  bar

TM03 6799 4506

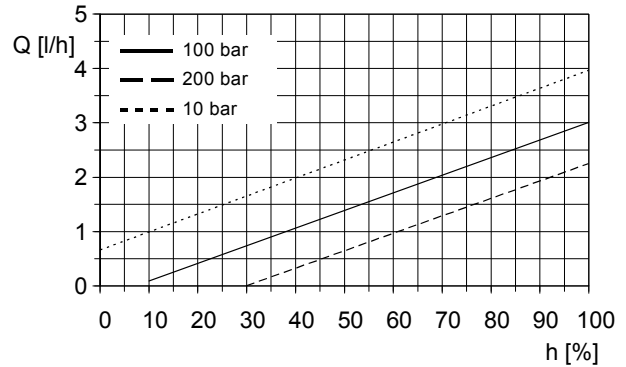

Fig. 51 DMH 2.2-200 (50 Hz),  $Q_0 = 75$  bar

TM03 6800 4506

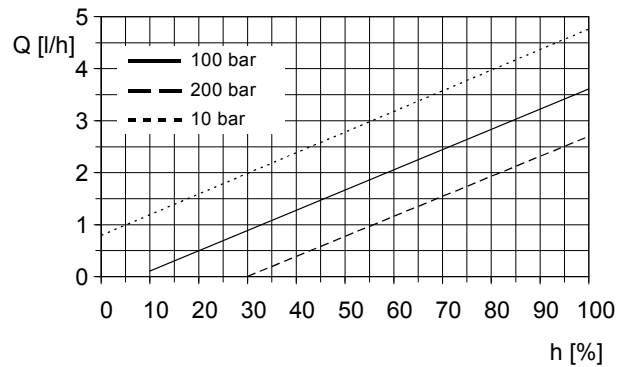

Fig. 52 DMH 2.2-200 (60 Hz),  $Q_0 = 75$  bar

TM03 6801 4506

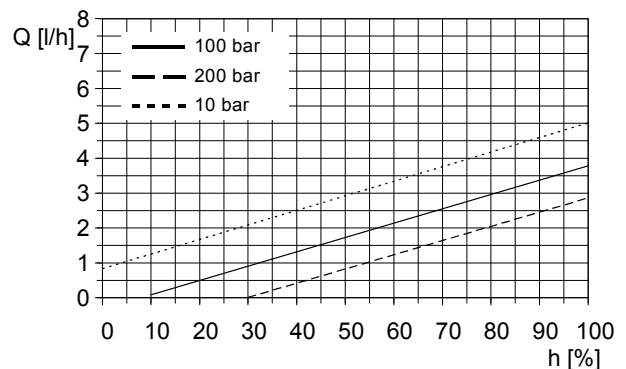

Fig. 53 DMH 2.5-200 (50 Hz),  $Q_0 = 75$  bar

TM03 6802 4506

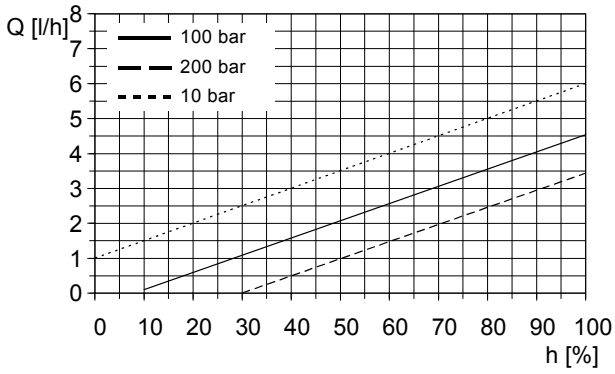

Fig. 54 DMH 2.5-200 (60 Hz),  $Q_0 = 75$  bar

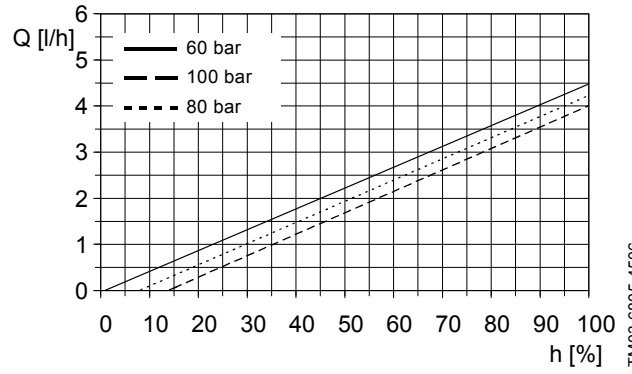

Fig. 58 DMH 4.2-100 (50 Hz),  $Q_0 = 60$  bar

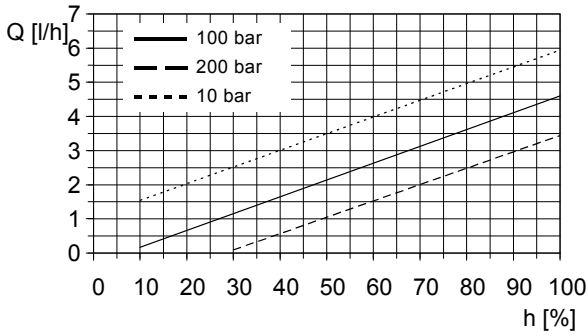

Fig. 55 DMH 3.3-200 (50 Hz),  $Q_0 = 75$  bar

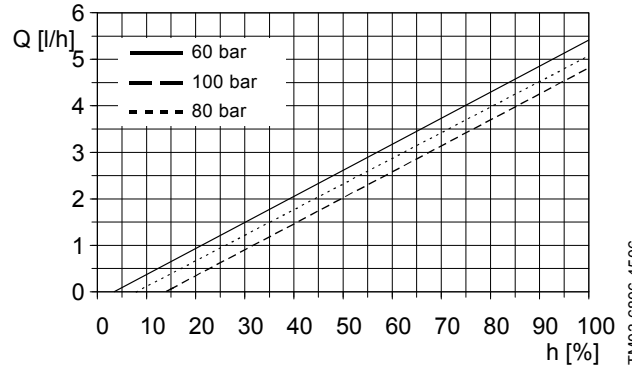

Fig. 59 DMH 4.2-100 (60 Hz),  $Q_0 = 60$  bar

DMH 281

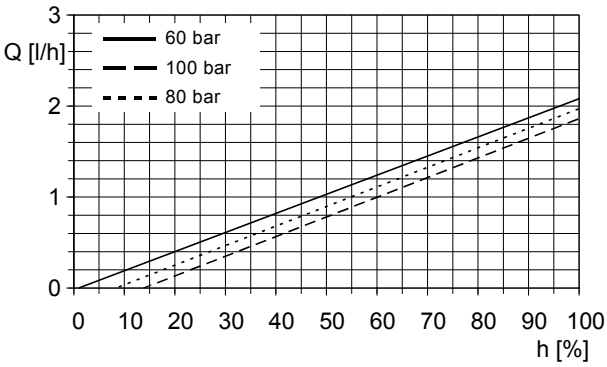

Fig. 56 DMH 2-100 (50 Hz),  $Q_0 = 60$  bar

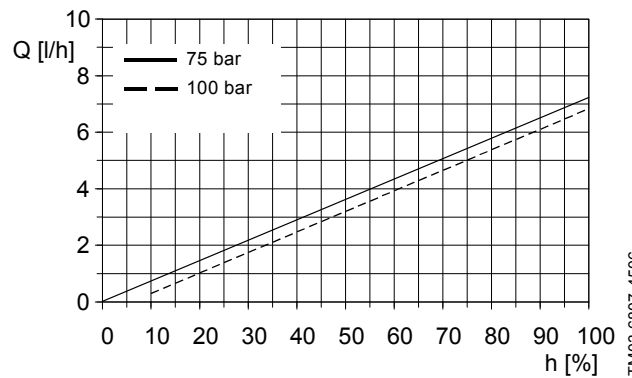

Fig. 60 DMH 6.4-100 (50 Hz),  $Q_0 = 75$  bar

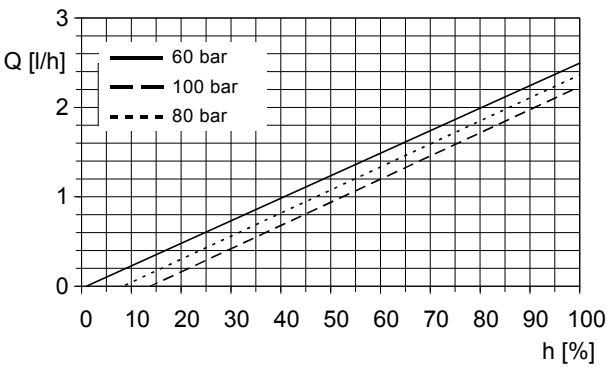

Fig. 57 DMH 2-100 (60 Hz),  $Q_0 = 60$  bar

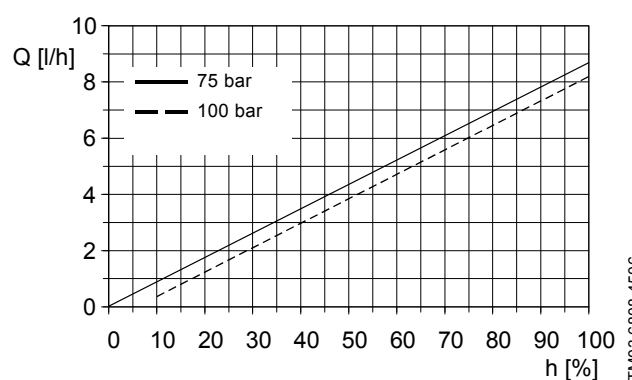

Fig. 61 DMH 6.4-100 (60 Hz),  $Q_0 = 75$  bar

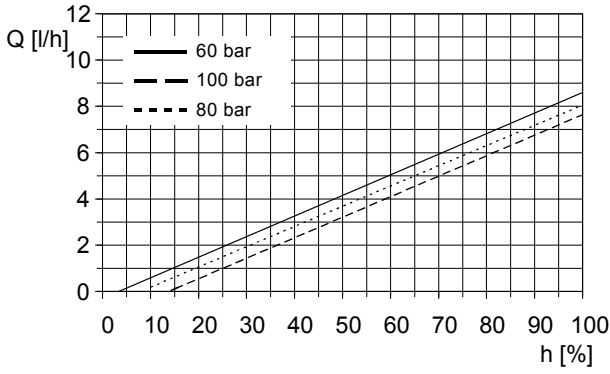

Fig. 62 DMH 8-100 (50 Hz),  $Q_0 = 60$  bar

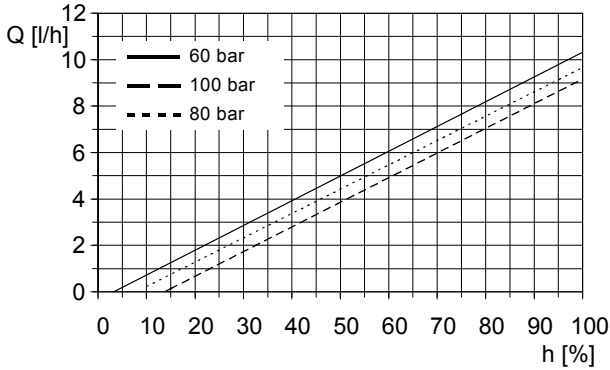

Fig. 63 DMH 8-100 (60 Hz),  $Q_0 = 60$  bar

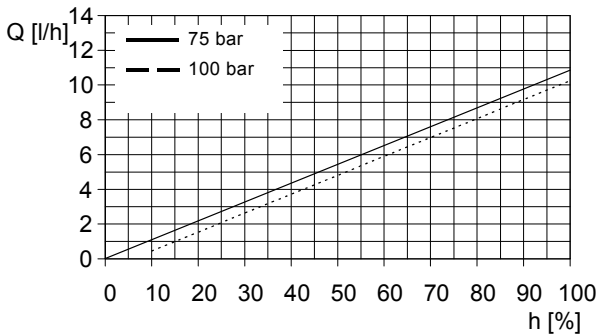

Fig. 64 DMH 9.6-100 (50 Hz),  $Q_0 = 75$  bar

DMH 283

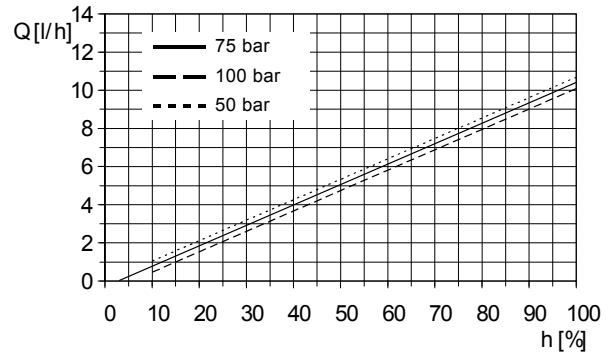

Fig. 65 DMH 10-100 (50 Hz),  $Q_0 = 75$  bar

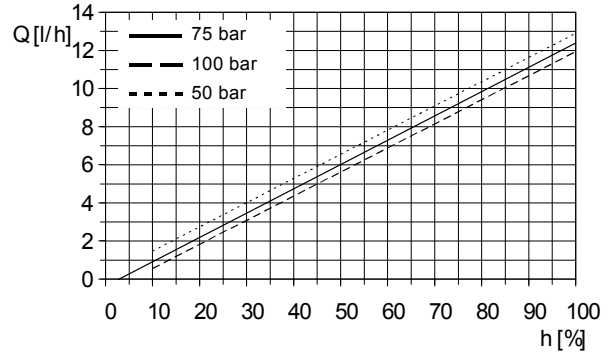

Fig. 66 DMH 10-100 (60 Hz),  $Q_0 = 75$  bar

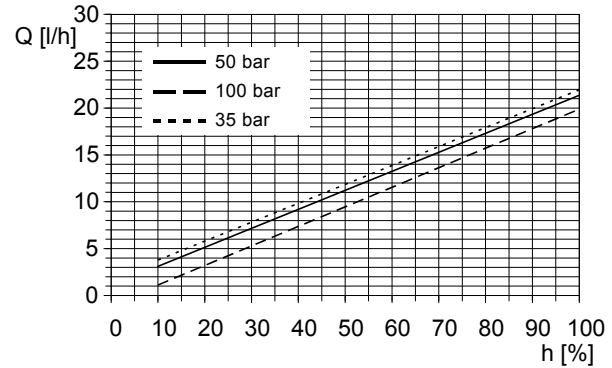

Fig. 67 DMH 19-100 (50 Hz),  $Q_0 = 75$  bar

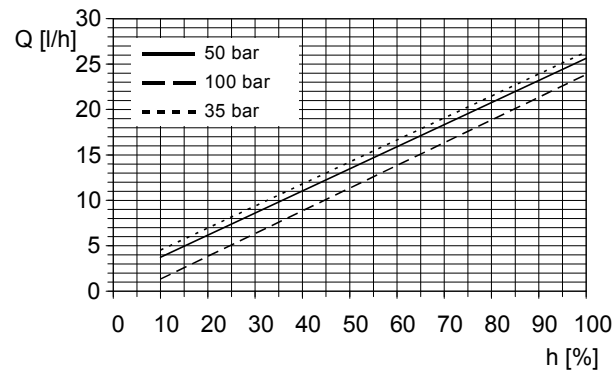

Fig. 68 DMH 19-100 (60 Hz),  $Q_0 = 75$  bar



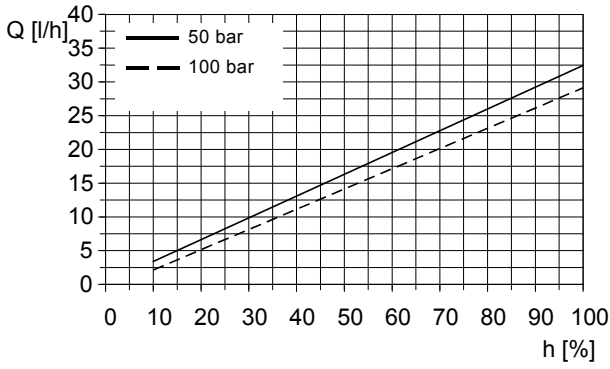

Fig. 69 DMH 27-100 (50 Hz),  $Q_0 = 75$  bar

TM03 6814 4506

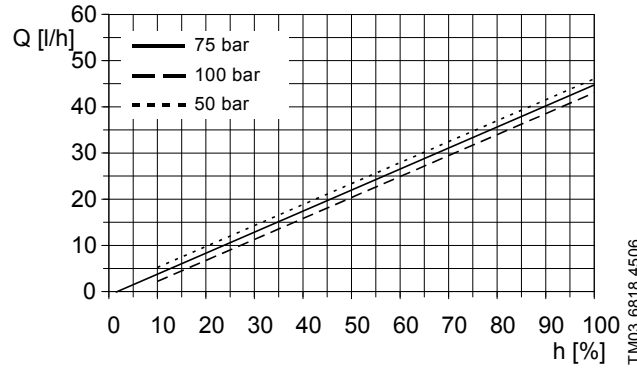

Fig. 73 DMH 40-100 (50 Hz),  $Q_0 = 75$  bar

TM03 6818 4506

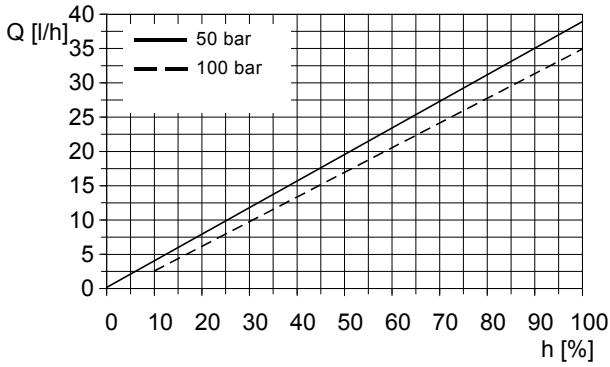

Fig. 70 DMH 27-100 (60 Hz),  $Q_0 = 75$  bar

TM03 6815 4506

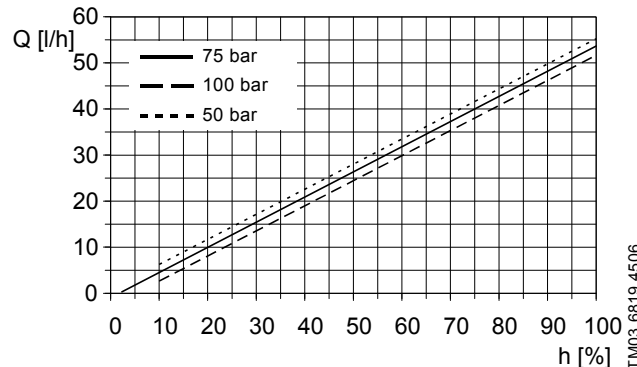

Fig. 74 DMH 40-100 (60 Hz),  $Q_0 = 75$  bar

TM03 6819 4506

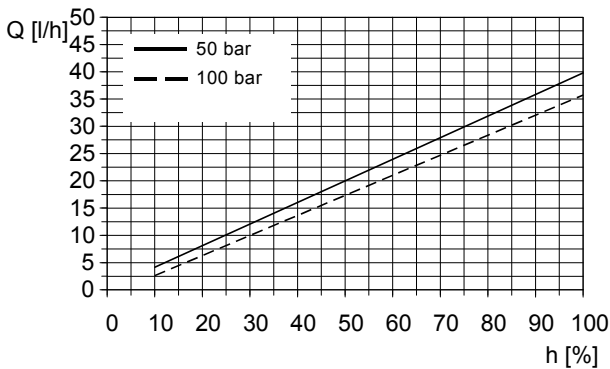

Fig. 71 DMH 33-100 (50 Hz),  $Q_0 = 75$  bar

TM03 6816 4506

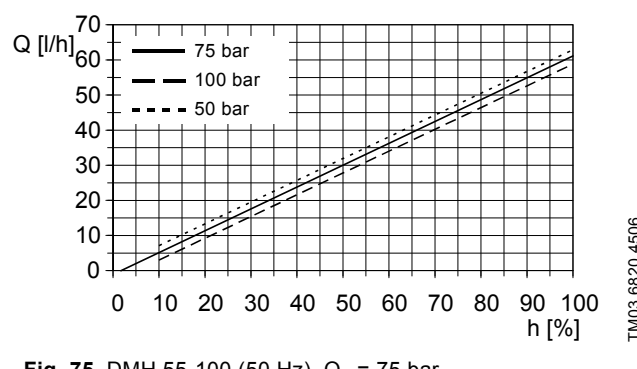

Fig. 75 DMH 55-100 (50 Hz),  $Q_0 = 75$  bar

TM03 6820 4506

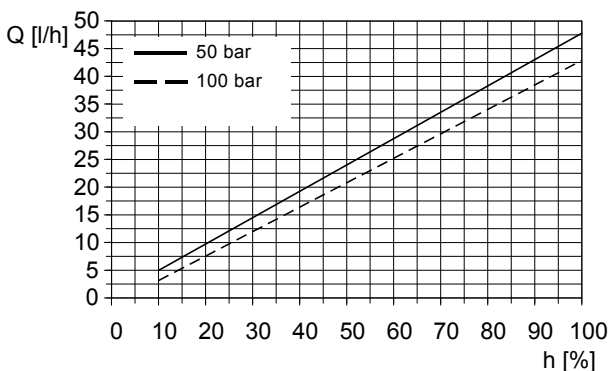

Fig. 72 DMH 33-100 (60 Hz),  $Q_0 = 75$  bar

TM03 6817 4506

DMH 285

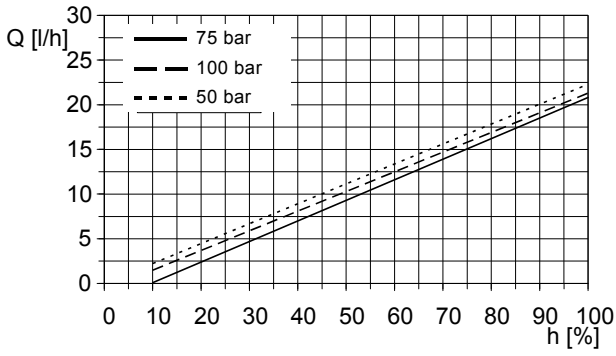

Fig. 76 DMH 20-100 (50 Hz),  $Q_0 = 75$  bar

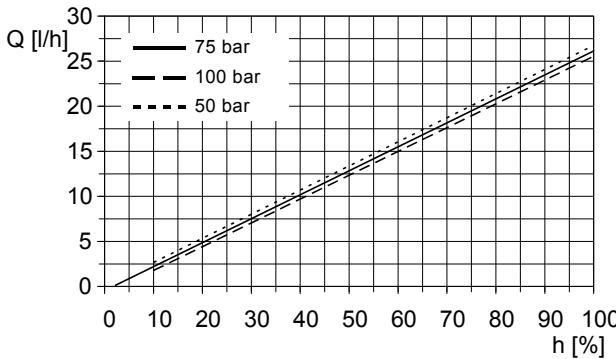

Fig. 77 DMH 20-100 (60 Hz),  $Q_0 = 75$  bar

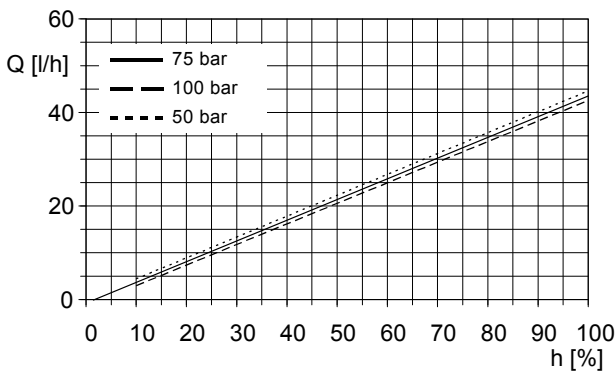

Fig. 78 DMH 40-100 (50 Hz),  $Q_0 = 75$  bar

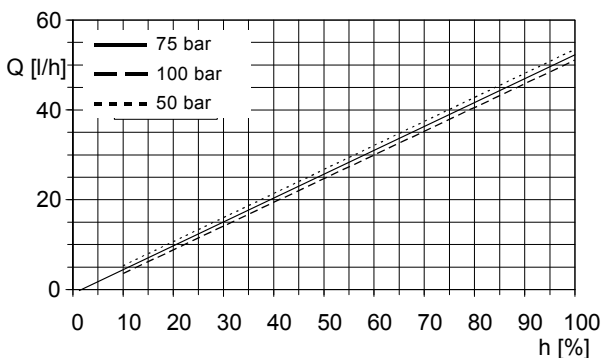

Fig. 79 DMH 40-100 (60 Hz),  $Q_0 = 75$  bar

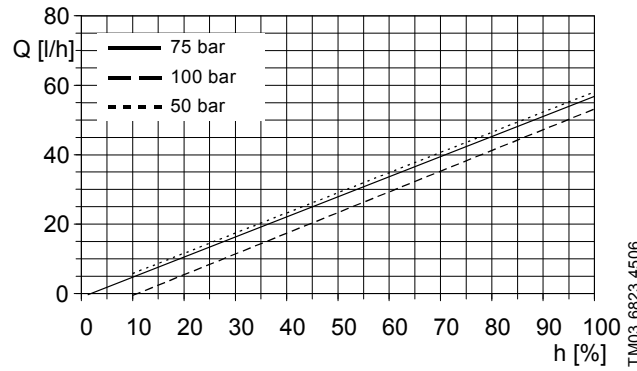

Fig. 80 DMH 52-100 (50 Hz),  $Q_0 = 75$  bar



Fig. 81 DMH 52-100 (60 Hz),  $Q_0 = 75$  bar

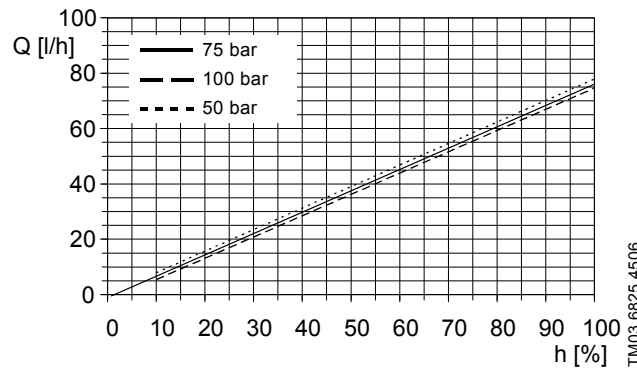

Fig. 82 DMH 70-100 (50 Hz),  $Q_0 = 75$  bar

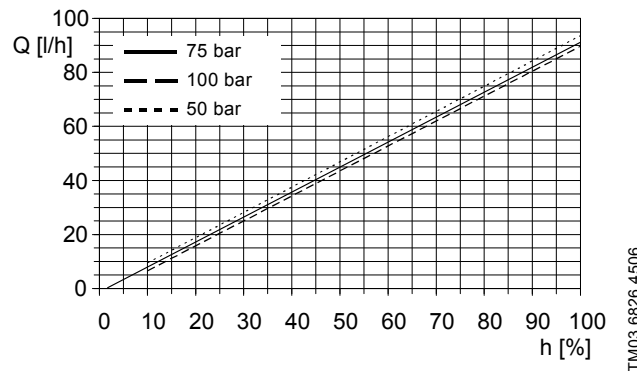

Fig. 83 DMH 70-100 (60 Hz),  $Q_0 = 75$  bar

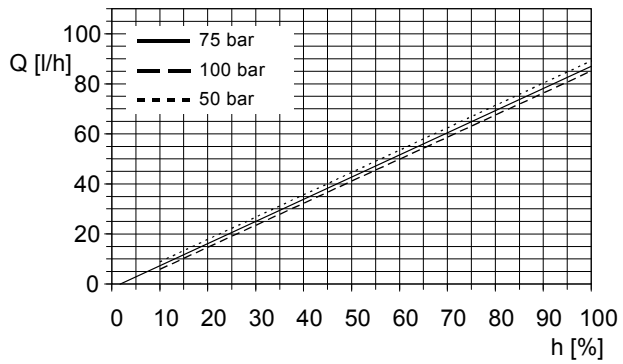

Fig. 84 DMH 80-100 (50 Hz),  $Q_0 = 75$  bar

TM03 6827 4506

DMH 286

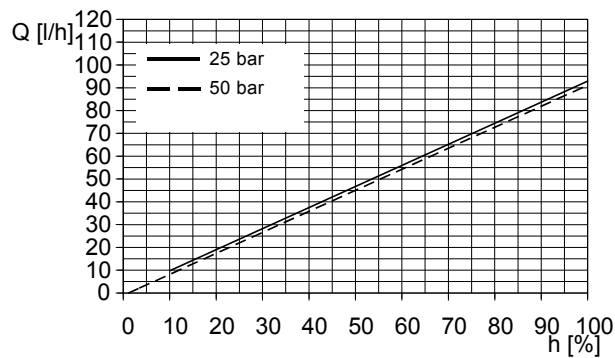

Fig. 87 DMH 85-50 (50 Hz),  $Q_0 = 25$  bar

TM03 6873 4506

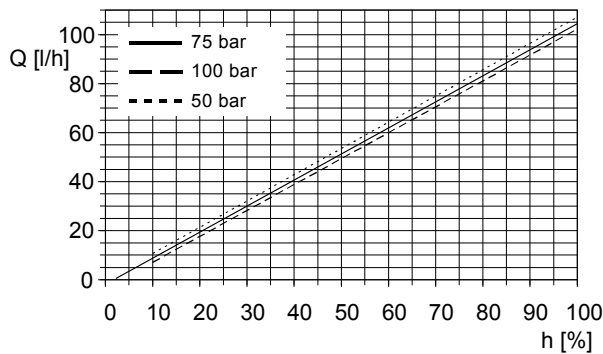

Fig. 85 DMH 80-100 (60 Hz),  $Q_0 = 75$  bar

TM03 6828 4506

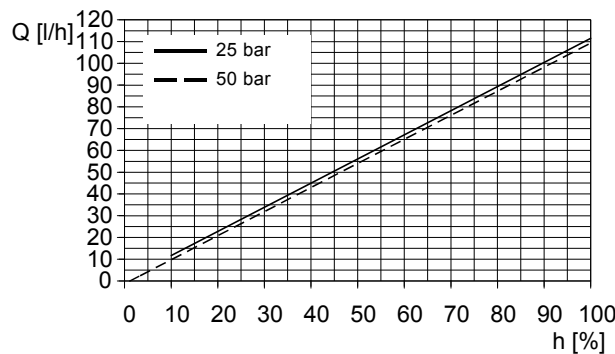

Fig. 88 DMH 85-50 (60 Hz),  $Q_0 = 25$  bar

TM03 6874 4506

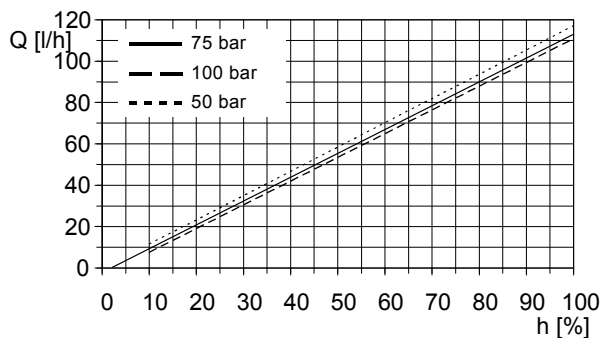

Fig. 86 DMH 105-100 (50 Hz),  $Q_0 = 75$  bar

TM03 6829 4506

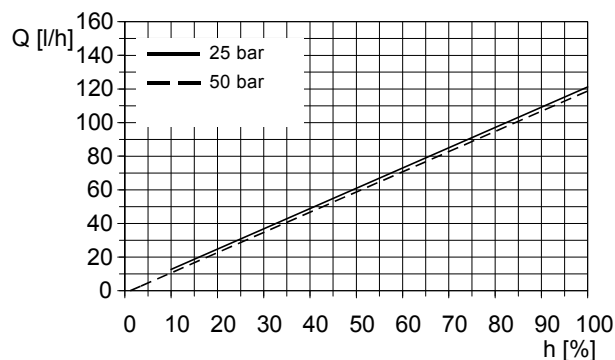

Fig. 89 DMH 111-50 (50 Hz),  $Q_0 = 25$  bar

TM03 6875 4506

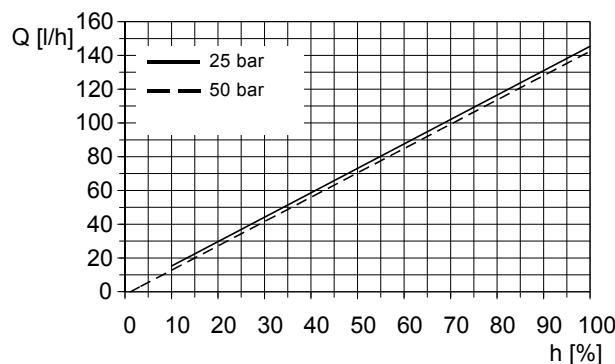

Fig. 90 DMH 111-50 (60 Hz),  $Q_0 = 25$  bar

TM03 6876 4506

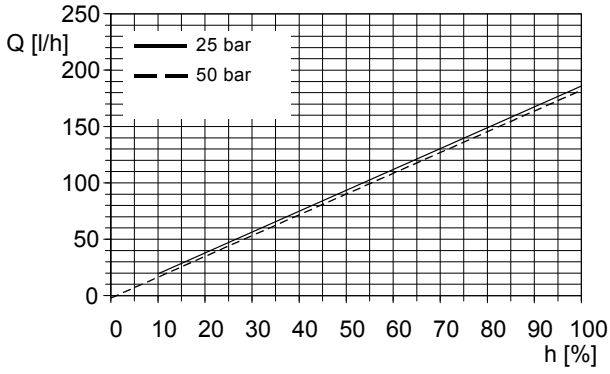

Fig. 91 DMH 170-50 (50 Hz),  $Q_0 = 25$  bar

TM03 6830 4506

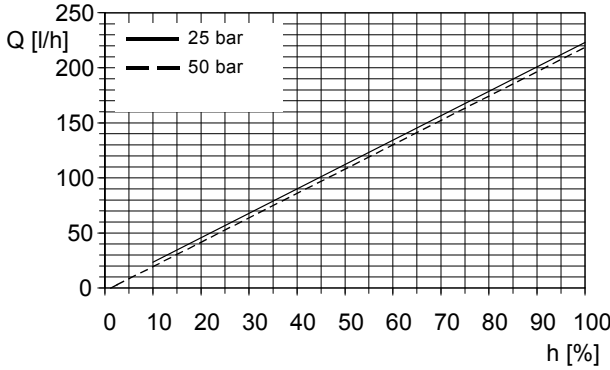

Fig. 92 DMH 170-50 (60 Hz),  $Q_0 = 25$  bar

TM03 6831 4506

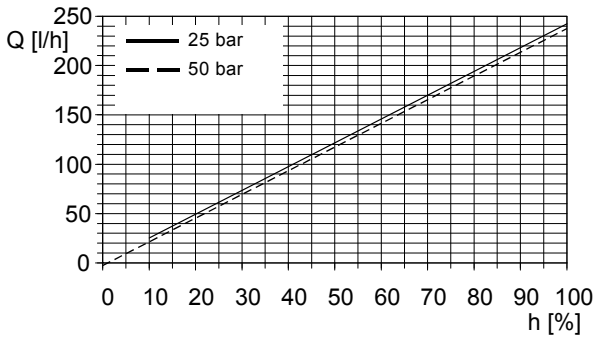

Fig. 93 DMH 222-50 (50 Hz),  $Q_0 = 25$  bar

TM03 6832 4506

DMH 287

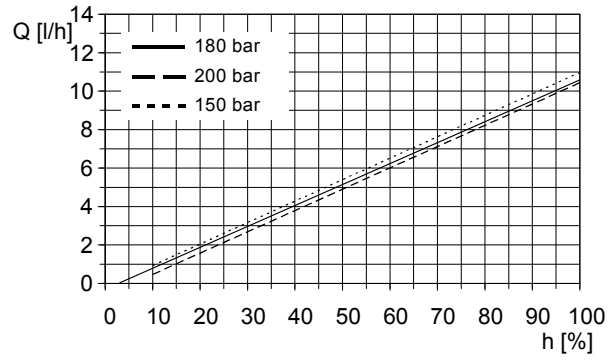

Fig. 94 DMH 9-200 (50 Hz),  $Q_0 = 180$  bar

TM03 6833 4506

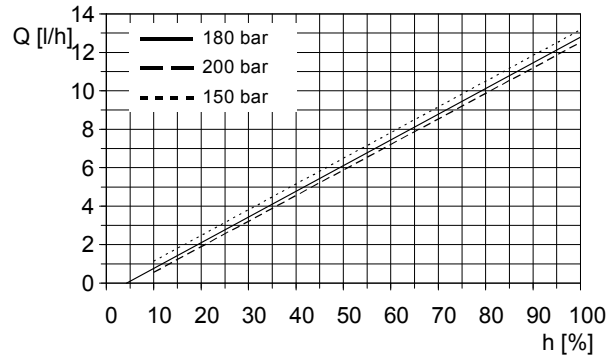

Fig. 95 DMH 9-200 (60 Hz),  $Q_0 = 180$  bar

TM03 6834 4506

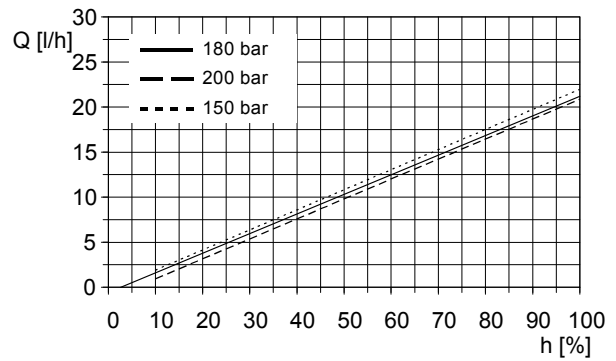

Fig. 96 DMH 18-200 (50 Hz),  $Q_0 = 180$  bar

TM03 6835 4506

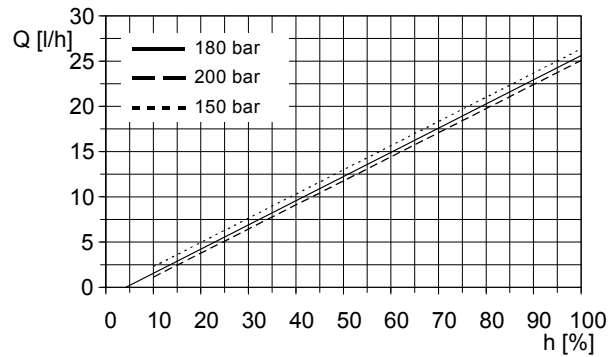
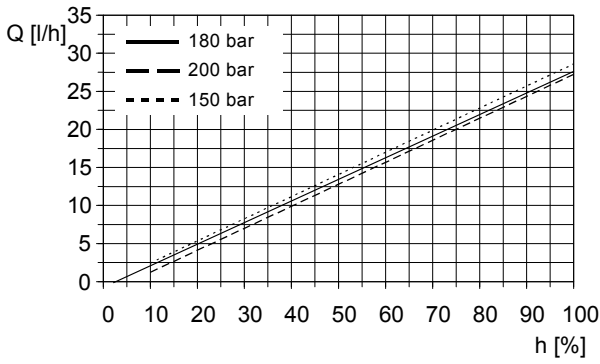

Fig. 97 DMH 18-200 (60 Hz),  $Q_0 = 180$  bar

TM03 6836 4506



TM03 6837 4506

Fig. 98 DMH 23-200 (50 Hz),  $Q_0 = 180$  bar

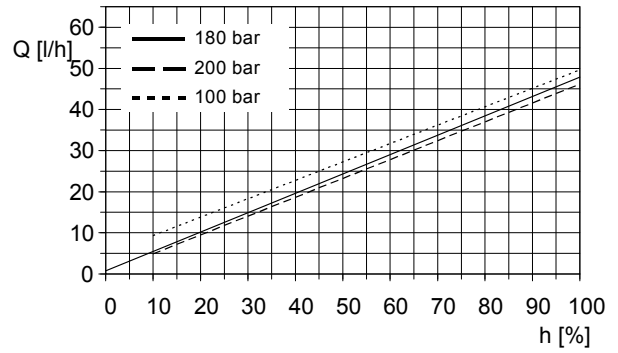

TM03 6841 4506

Fig. 102 DMH 36-200 (50 Hz),  $Q_0 = 180$  bar

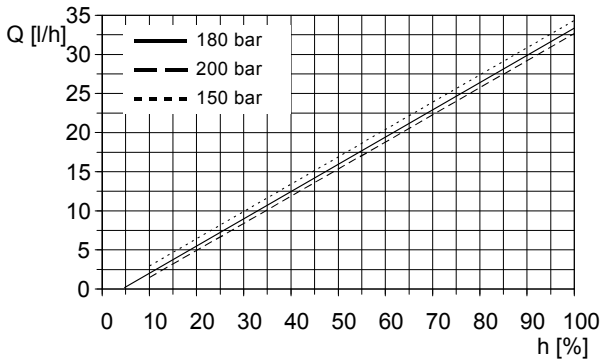

TM03 6838 4506

Fig. 99 DMH 23-200 (60 Hz),  $Q_0 = 180$  bar

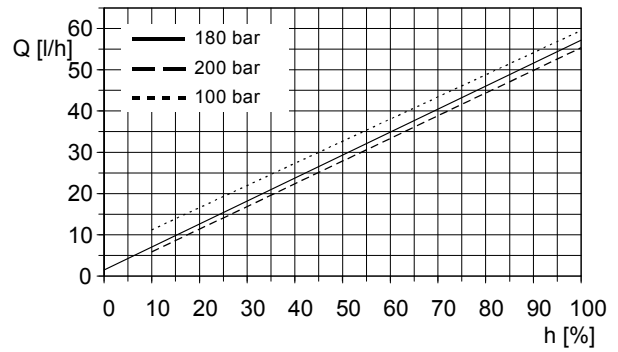

TM03 6842 4506

Fig. 103 DMH 36-200 (60 Hz),  $Q_0 = 180$  bar

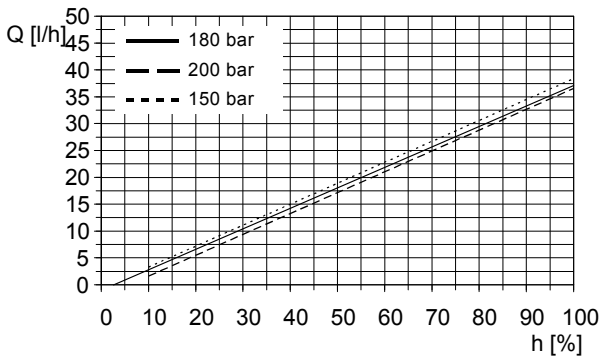

TM03 6839 4506

Fig. 100 DMH 31-200 (50 Hz),  $Q_0 = 180$  bar

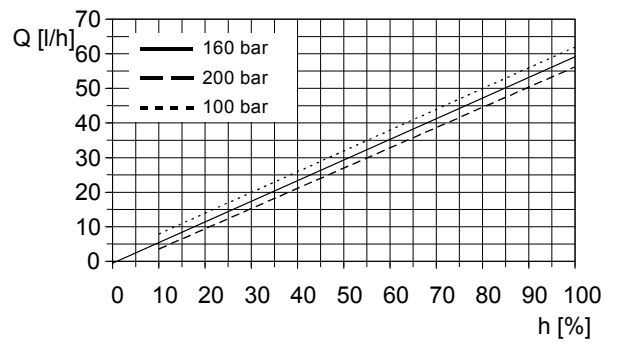

TM03 6843 4506

Fig. 104 DMH 50-200 (50 Hz),  $Q_0 = 160$  bar

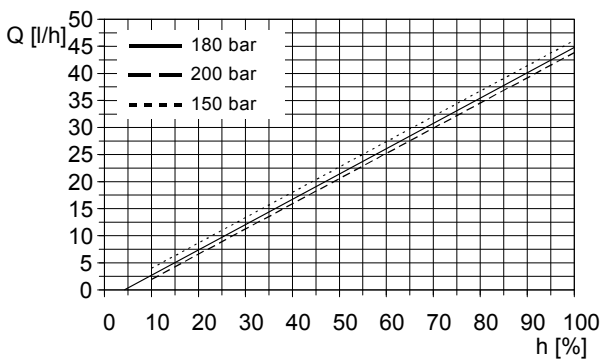

TM03 6840 4506

Fig. 101 DMH 31-200 (60 Hz),  $Q_0 = 180$  bar

DMH 288

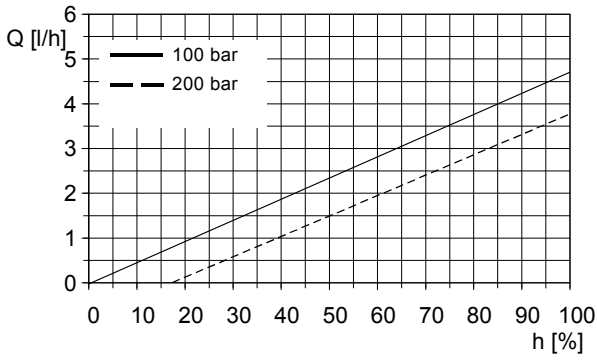

Fig. 105 DMH 3-200 (50 Hz),  $Q_0 = 100$  bar

TM03 6844 4506

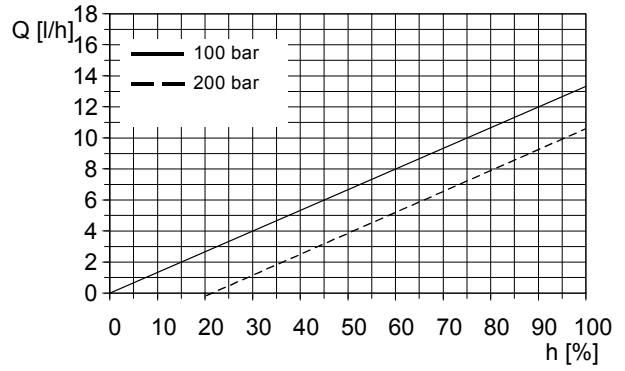

Fig. 109 DMH 10-200 (50 Hz),  $Q_0 = 100$  bar

TM03 6848 4506

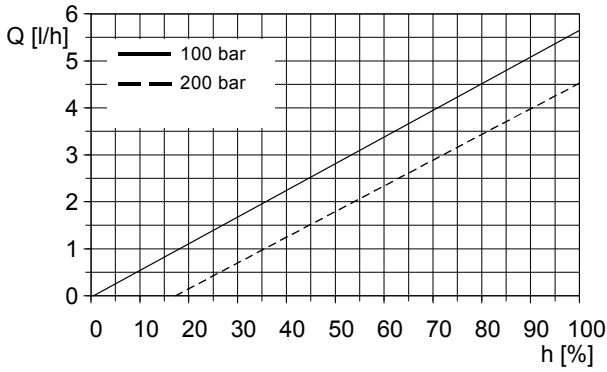

Fig. 106 DMH 3-200 (60 Hz),  $Q_0 = 100$  bar

TM03 6845 4506

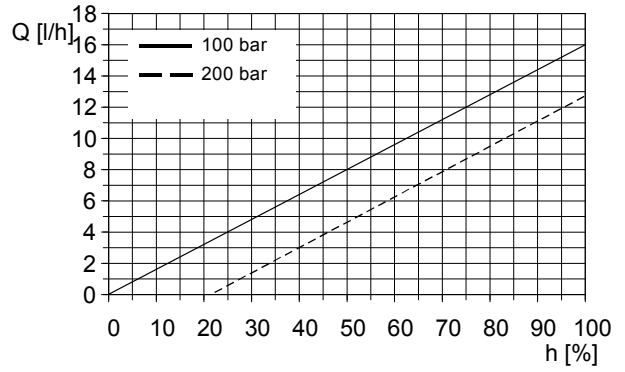

Fig. 110 DMH 10-200 (60 Hz),  $Q_0 = 100$  bar

TM03 6849 4506

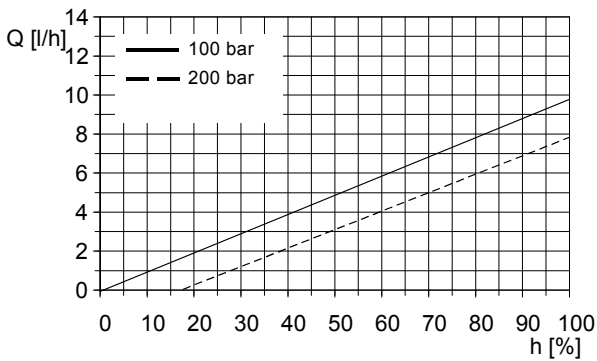

Fig. 107 DMH 7.5-200 (50 Hz),  $Q_0 = 100$  bar

TM03 6846 4506

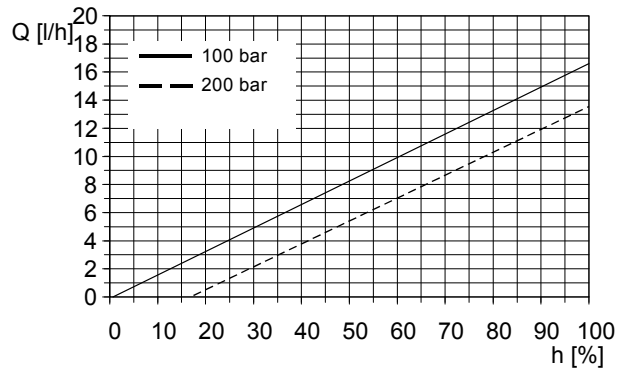

Fig. 111 DMH 13-200 (50 Hz),  $Q_0 = 100$  bar

TM03 6850 4506

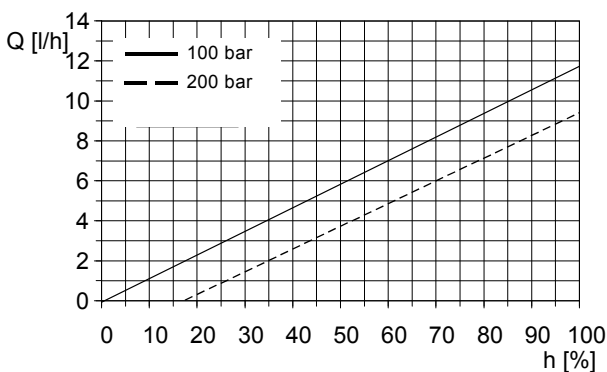

Fig. 108 DMH 7.5-200 (60 Hz),  $Q_0 = 100$  bar

TM03 6847 4506

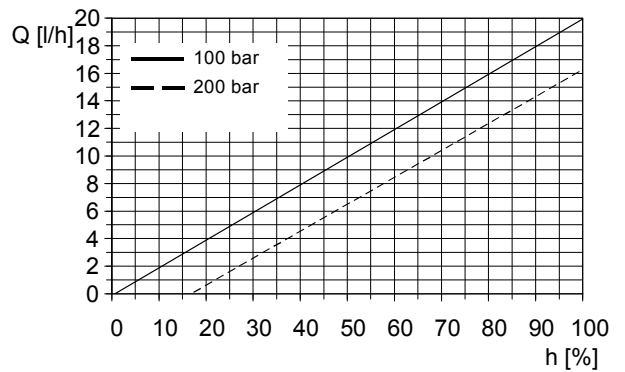

Fig. 112 DMH 13-200 (60 Hz),  $Q_0 = 100$  bar

TM03 6851 4506

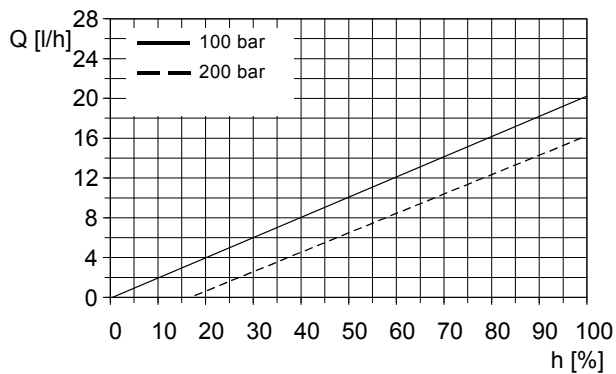

Fig. 113 DMH 15-200 (50 Hz),  $Q_0 = 100$  bar

TM03 6852 4506

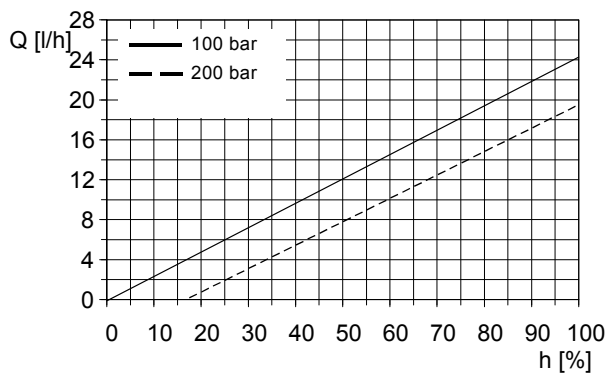

Fig. 114 DMH 15-200 (60 Hz),  $Q_0 = 100$  bar

TM03 6853 4506

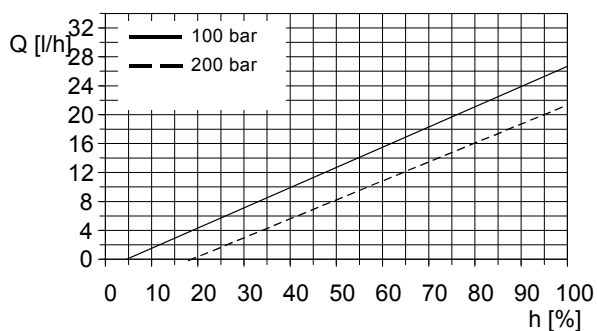

Fig. 115 DMH 21-200 (50 Hz),  $Q_0 = 100$  bar

TM03 6854 4506

### 13. Disposal

This product or parts of it must be disposed of in an environmentally sound way. Use appropriate waste collection services. If this is not possible, contact the nearest Grundfos company or service workshop.

Subject to alterations.

# Safety declaration

Please copy, fill in and sign this sheet and attach it to the pump returned for service.

**Note** Fill in this document using English or German language.

We hereby declare that this product is free from hazardous chemicals,  
biological and radioactive substances:

Product type: \_\_\_\_\_

Model number: \_\_\_\_\_

No media or water: \_\_\_\_\_

A chemical solution, name: \_\_\_\_\_

(see pump nameplate)

## Fault description

Please make a circle around the damaged part.  
In the case of an electrical or functional fault, please mark the cabinet.

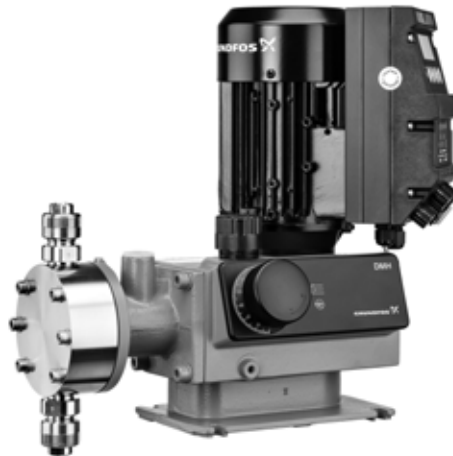

GRA3504

Please give a short description of the fault:

\_\_\_\_\_  
Date and signature

\_\_\_\_\_  
Company stamp







**Argentina**

Bombas GRUNDFOS de Argentina S.A.  
Ruta Panamericana km. 37.500 Centro  
Industrial Garin  
1619 - Garin Pcia. de B.A.  
Phone: +54-3327 414 444  
Telefax: +54-3327 411 111

**Australia**

GRUNDFOS Pumps Pty. Ltd.  
P.O. Box 2040  
Regency Park  
South Australia 5942  
Phone: +61-8-8461-4611  
Telefax: +61-8-8340 0155

**Austria**

GRUNDFOS Pumpen Vertrieb Ges.m.b.H.  
Grundfosstraße 2  
A-5082 Grödig/Salzburg  
Tel.: +43-6246-883-0  
Telefax: +43-6246-883-30

**Belgium**

N.V. GRUNDFOS Bellux S.A.  
Boomssesteenweg 81-83  
B-2630 Aartselaar  
Tél.: +32-3-870 7300  
Télécopie: +32-3-870 7301

**Belarus**

Представительство ГРУНДФОС в  
Минске  
220125, Минск  
ул. Шафарнянская, 11, оф. 56  
Тел.: +7 (375 17) 286 39 72, 286 39 73  
Факс: +7 (375 17) 286 39 71  
E-mail: minsk@grundfos.com

**Bosnia/Herzegovina**

GRUNDFOS Sarajevo  
Trg Heroja 16,  
BiH-71000 Sarajevo  
Phone: +387 33 713 290  
Telefax: +387 33 659 079  
e-mail: grundfos@bih.net.ba

**Brazil**

BOMBAS GRUNDFOS DO BRASIL  
Av. Humberto de Alencar Castelo Branco,  
630  
CEP 09850 - 300  
São Bernardo do Campo - SP  
Phone: +55-11 4393 5533  
Telefax: +55-11 4343 5015

**Bulgaria**

Grundfos Bulgaria EOOD  
Slatina District  
Iztochna Tangenta street no. 100  
BG - 1592 Sofia  
Tel. +359 2 49 22 200  
Fax. +359 2 49 22 201  
email: bulgaria@grundfos.bg

**Canada**

GRUNDFOS Canada Inc.  
2941 Brighton Road  
Oakville, Ontario  
L6H 6C9  
Phone: +1-905 829 9533  
Telefax: +1-905 829 9512

**China**

**Grundfos Alldos  
Dosing & Disinfection**  
ALLDOS (Shanghai) Water Technology  
Co. Ltd.  
West Unit, 1 Floor, No. 2 Building (T 4-2)  
278 Jinhua Road, Jin Qiao Export Process-  
ing Zone  
Pudong New Area  
Shanghai, 201206  
Phone: +86 21 5055 1012  
Telefax: +86 21 5032 0596  
E-mail: grundfosalldos-CN@grundfos.com

**China**

GRUNDFOS Pumps (Shanghai) Co. Ltd.  
50/F Maxdo Centre No. 8 Xing Yi Rd.  
Hongqiao Development Zone  
Shanghai 200336  
PRC  
Phone: +86-21 6122 5222  
Telefax: +86-21 6122 5333

**Croatia**

GRUNDFOS CROATIA d.o.o.  
Cebini 37, Buzin  
HR-10010 Zagreb  
Phone: +385 1 6595 400  
Telefax: +385 1 6595 499  
www.grundfos.hr

**Czech Republic**

GRUNDFOS s.r.o.  
Čapkovského 21  
779 00 Olomouc  
Phone: +420-585-716 111  
Telefax: +420-585-716 299

**Denmark**

GRUNDFOS DK A/S  
Martin Bachs Vej 3  
DK-8850 Bjerringbro  
Tlf.: +45-87 50 50 50  
Telefax: +45-87 50 51 51  
E-mail: info\_GDK@grundfos.com  
www.grundfos.com/DK

**Estonia**

GRUNDFOS Pumps Eesti OÜ  
Peterburi tee 92G  
11415 Tallinn  
Tel: + 372 606 1690  
Fax: + 372 606 1691

**Finland**

OY GRUNDFOS Pumpat AB  
Mestarintie 11  
FIN-01730 Vantaa  
Phone: +358-(0)207 889 900  
Telefax: +358-(0)207 889 550

**France**

Pompes GRUNDFOS Distribution S.A.  
Parc d'Activités de Chesnes  
57, rue de Malacombe  
F-38290 St. Quentin Fallavier (Lyon)  
Tél.: +33-4 74 82 15 15  
Télécopie: +33-4 74 94 10 51

**Germany**

GRUNDFOS Water Treatment GmbH  
Reetzstraße 85  
D-76327 Pfinztal (Söllingen)  
Tel.: +49 7240 61-0  
Telefax: +49 7240 61-177  
E-mail: gwt@grundfos.com

**Germany**

GRUNDFOS GMBH  
Schlüterstr. 33  
40699 Erkrath  
Tel.: +49-(0) 211 929 69-0  
Telefax: +49-(0) 211 929 69-3799  
E-mail: infoservice@grundfos.de  
Service in Deutschland:  
E-mail: kundendienst@grundfos.de

**Greece**

GRUNDFOS Hellas A.E.B.E.  
20th km. Athinon-Markopoulou Av.  
P.O. Box 71  
GR-19002 Peania  
Phone: +0030-210-66 83 400  
Telefax: +0030-210-66 46 273

**Hong Kong**

GRUNDFOS Pumps (Hong Kong) Ltd.  
Unit 1, Ground floor  
Siu Wai Industrial Centre  
29-33 Wing Hong Street &  
68 King Lam Street, Cheung Sha Wan  
Kowloon  
Phone: +852-27861706 / 27861741  
Telefax: +852-27858664

**Hungary**

GRUNDFOS Hungária Kft.  
Park u. 8  
H-2045 Törökbálint,  
Phone: +36-23 511 110  
Telefax: +36-23 511 111

**India**

GRUNDFOS Pumps India Private Limited  
118 Old Mahabalipuram Road  
Thoraiakkam  
Chennai 600 097  
Phone: +91-44 4596 6800

**Indonesia**

PT GRUNDFOS Pompa  
Jl. Rawa Sumur III, Blok III / CC-1  
Kawasan Industri, Pulogadung  
Jakarta 13930  
Phone: +62-21-460 6909  
Telefax: +62-21-460 6910 / 460 6901

**Ireland**

GRUNDFOS (Ireland) Ltd.  
Unit A, Merrywell Business Park  
Ballymount Road Lower  
Dublin 12  
Phone: +353-1-4089 800  
Telefax: +353-1-4089 830

**Italy**

GRUNDFOS Pompe Italia S.r.l.  
Via Gran Sasso 4  
I-20060 Truccazzano (Milano)  
Tel.: +39-02-95838112  
Telefax: +39-02-95309290 / 95838461

**Japan**

GRUNDFOS Pumps K.K.  
Gotanda Metalion Bldg. 5F,  
5-21-15, Higashi-gotanda  
Shiagawa-ku, Tokyo,  
141-0022 Japan  
Phone: +81 35 448 1391  
Telefax: +81 35 448 9619

**Korea**

GRUNDFOS Pumps Korea Ltd.  
6th Floor, Aju Building 679-5  
Yeoksam-dong, Kangnam-ku, 135-916  
Seoul, Korea  
Phone: +82-2-5317 600  
Telefax: +82-2-5633 725

**Latvia**

SIA GRUNDFOS Pumps Latvia  
Deglava biznesa centrs  
Augusta Deglava ielā 60, LV-1035, Rīga,  
Tālr.: + 371 714 9640, 7 149 641  
Fakss: + 371 914 9646

**Lithuania**

GRUNDFOS Pumps UAB  
Smolensko g. 6  
LT-03201 Vilnius  
Tel: + 370 52 395 430  
Fax: + 370 52 395 431

**Malaysia**

GRUNDFOS Pumps Sdn. Bhd.  
7 Jalan Peguam U1/25  
Glenmarie Industrial Park  
40150 Shah Alam  
Selangor  
Phone: +60-3-5569 2922  
Telefax: +60-3-5569 2866

**Mexico**

Bombas GRUNDFOS de México S.A. de  
C.V.  
Boulevard TLC No. 15  
Parque Industrial Stiva Aeropuerto  
Apodaca, N.L. 66600  
Phone: +52-81-8144 4000  
Telefax: +52-81-8144 4010

**Netherlands**

GRUNDFOS Netherlands  
Veluwezoom 35  
1326 AE Almere  
Postbus 22015  
1302 CA ALMERE  
Tel.: +31-88-478 6336  
Telefax: +31-88-478 6332  
E-mail: info\_gnl@grundfos.com

**New Zealand**

GRUNDFOS Pumps NZ Ltd.  
17 Beatrice Tinsley Crescent  
North Harbour Industrial Estate  
Albany, Auckland  
Phone: +64-9-415 3240  
Telefax: +64-9-415 3250

**Norway**

GRUNDFOS Pumper A/S  
Strømsveien 344  
Postboks 235, Leirdal  
N-1011 Oslo  
Tlf.: +47-22 90 47 00  
Telefax: +47-22 32 21 50

**Poland**

GRUNDFOS Pompy Sp. z o.o.  
ul. Klonowa 23  
Baranowo k. Poznania  
PL-62-081 Przeźmierowo  
Tel: (+48-61) 650 13 00  
Fax: (+48-61) 650 13 50

**Portugal**

Bombas GRUNDFOS Portugal, S.A.  
Rua Calvet de Magalhães, 241  
Apartado 1079  
P-2770-153 Paço de Arcos  
Tel.: +351-21-440 76 00  
Telefax: +351-21-440 76 90

**Romania**

GRUNDFOS Pompe România SRL  
Bd. Biruintei, nr 103  
Pantelimon county Ilfov  
Phone: +40 21 200 4100  
Telefax: +40 21 200 4101  
E-mail: romania@grundfos.ro

**Russia**

ООО ГРУНДФОС  
Россия, 109544 Москва, ул. Школьная  
39  
Тел. (+7) 495 737 30 00, 564 88 00  
Факс (+7) 495 737 75 36, 564 88 11  
E-mail grundfos.moscow@grundfos.com

**Serbia**

GRUNDFOS Predstavništvo Beograd  
Dr. Milutina Ivkovića 2a/29  
YU-11000 Beograd  
Phone: +381 11 26 47 877 / 11 26 47 496  
Telefax: +381 11 26 48 340

**Singapore**

GRUNDFOS (Singapore) Pte. Ltd.  
25 Jalan Tukang  
Singapore 619264  
Phone: +65-6681 9688  
Telefax: +65-6681 9689

**Slovenia**

GRUNDFOS d.o.o.  
Šlandrova 8b, SI-1231 Ljubljana-Črnuče  
Phone: +386 1 568 0610  
Telefax: +386 1 568 0619  
E-mail: slovenia@grundfos.si

**South Africa**

Grundfos (PTY) Ltd.  
Corner Mountjoy and George Allen Roads  
Wilbart Ext. 2  
Bedfordview 2008  
Phone: (+27) 11 579 4800  
Fax: (+27) 11 455 6066  
E-mail: Ismart@grundfos.com

**Spain**

Bombas GRUNDFOS España S.A.  
Camino de la Fuentevilla, s/n  
E-28110 Algete (Madrid)  
Tel.: +34-91-848 8800  
Telefax: +34-91-628 0465

**Sweden**

GRUNDFOS AB  
(Box 333) Lunnagårdsgatan 6  
431 24 Mölndal  
Tel.: +46 31 332 23 000  
Telefax: +46 31-331 94 60

**Switzerland**

GRUNDFOS ALLDOS International AG  
Schönmattpfaffen 4  
CH-4153 Reinach  
Tel.: +41-61-717 5555  
Telefax: +41-61-717 5500  
E-mail: grundfosalldos-CH@grundfos.com

**Switzerland**

GRUNDFOS Pumpen AG  
Bruggacherstrasse 10  
CH-8117 Fällanden/ZH  
Tel.: +41-1-806 8111  
Telefax: +41-1-806 8115

**Taiwan**

GRUNDFOS Pumps (Taiwan) Ltd.  
7 Floor, 219 Min-Chuan Road  
Taichung, Taiwan, R.O.C.  
Phone: +886-4-2305 0868  
Telefax: +886-4-2305 0878

**Thailand**

GRUNDFOS (Thailand) Ltd.  
92 Chaloeam Phrakiat Rama 9 Road,  
Dokmai, Pravej, Bangkok 10250  
Phone: +66-2-725 8999  
Telefax: +66-2-725 8998

**Turkey**

GRUNDFOS POMPA San. ve Tic. Ltd. Sti.  
Gebze Organize Sanayi Bölgesi  
İhsan dede Caddesi,  
2. yol 200. Sokak No. 204  
41490 Gebze/ Kocaeli  
Phone: +90 - 262-679 7979  
Telefax: +90 - 262-679 7905  
E-mail: satis@grundfos.com

**Ukraine**

ТОВ ГРУНДФОС УКРАЇНА  
01010 Київ, Вул. Московська 86,  
Тел.: (+38 044) 390 40 50  
Факс: (+38 044) 390 40 59  
E-mail: ukraine@grundfos.com

**United Arab Emirates**

GRUNDFOS Gulf Distribution  
P.O. Box 16768  
Jebel Ali Free Zone  
Dubai  
Phone: +971-4- 8815 166  
Telefax: +971-4-8815 136

**United Kingdom**

GRUNDFOS Pumps Ltd.  
Grovebury Road  
Leighton Buzzard/Beds. LU7 4TL  
Phone: +44-1525-850000  
Telefax: +44-1525-850011

**U.S.A.**

GRUNDFOS Pumps Corporation  
17100 West 118th Terrace  
Olathe, Kansas 66061  
Phone: +1-913-227-3400  
Telefax: +1-913-227-3500

**Uzbekistan**

Grundfos Tashkent, Uzbekistan The Repre-  
sentative Office of Grundfos Kazakhstan in  
Uzbekistan  
38a, Oybek street, Tashkent  
Телефон: (+998) 71 150 3290 / 71 150  
3291  
Факс: (+998) 71 150 3292

Addresses revised 06.05.2013

<b>96771794</b> 1213
ECM: 1123334