



Tool Products

OPERATOR'S MANUAL

INCLUDING: OPERATION, INSTALLATION & MAINTENANCE

SECTION	M30
MANUAL	33
Released:	3-1-77
Revised:	1-27-95
Form:	1018-2

"O" SERIES "QRT" SCREWDRIVERS

Models: 8506-A(), 8509-A(),
8515-A() and 8521-A().



⚠ WARNING

**READ THIS MANUAL CAREFULLY BEFORE INSTALLING,
OPERATING OR SERVICING THIS EQUIPMENT.**

FAILURE TO OBSERVE THE FOLLOWING WARNINGS COULD RESULT IN INJURY.

Pneumatic tools should always be installed and used in accordance with A.N.S.I. B186.1 "Safety Code For Portable Air Tools."

⚠ WARNING

- Operate this tool at 90 p.s.i.g. (6.2 bar) maximum air pressure at the air inlet of the tool.
- Disconnect air supply from tool before removing/installing bit, socket or device attached to tool or performing maintenance procedures.
- Keep hands, clothing and long hair away from rotating end of tool.
- Anticipate and be alert for sudden changes in motion during start up and operation of any power tool.
- Never exceed rated r.p.m. of tool.
- Wear suitable eye and hearing protection while operating tool.
- Tool shaft can continue to rotate briefly after throttle is released.
- Do not lubricate tools with flammable or volatile liquids such as kerosene, diesel or jet fuel.
- Do not remove any labels. Replace any damaged label.
- Use only accessories recommended by ARO.

⚠ WARNING

Repeated prolonged operator exposure to vibrations which may be generated in the use of certain hand-held tools may produce Raynaud's phenomenon, commonly referred to as Whitefinger disease. The phenomenon produces numbness and burning sensations in the hand and may cause circulation and nerve damage as well as tissue necrosis. Repetitive users of hand-held tools who experience vibrations should closely monitor duration of use and their physical condition.

NOTICE

- The use of other than genuine ARO replacement parts may result in safety hazards, decreased tool performance and increased maintenance and may invalidate all warranties.
- ARO is not responsible for customer modification of tools for applications on which ARO was not consulted.
- Tool maintenance and repair should be performed by authorized, trained, competent personnel. Consult your nearest ARO authorized servicer.
- It is the responsibility of the employer to place the information in this manual into the hands of the operator.

For parts and service information, contact your local ARO distributor, or the Customer Service Dept. of the Ingersoll-Rand Distribution Center, White House, TN at PH: (615) 672-0321, FAX: (615) 672-0601.

ARO Tool Products

Ingersoll-Rand Company

1725 U.S. No. 1 North • P.O. Box 8000 • Southern Pines, NC 28388-8000
©1995 THE ARO CORPORATION • PRINTED IN U.S.A.



Part of worldwide Ingersoll-Rand

FAILURE TO OBSERVE THE FOLLOWING WARNINGS COULD RESULT IN INJURY.

⚠ WARNING



Wear eye protection when operating or performing maintenance on this tool.

⚠ WARNING



Wear hearing protection when operating this tool.

⚠ WARNING



Turn off air supply and disconnect air supply hose before installing, removing or adjusting any accessory on this tool, or before performing any maintenance on this tool.

⚠ WARNING



Air powered tools can vibrate in use. Vibration, repetitive motions or uncomfortable positions may be harmful to your hands and arms. Stop using any tool if discomfort, tingling feeling or pain occurs. Seek medical advice before resuming use.

⚠ WARNING



Do not carry the tool by the hose.

⚠ WARNING



Do not use damaged, frayed or deteriorated air hoses and fittings.

⚠ WARNING



Do not overreach when operating this tool. Keep body stance balanced and firm.

⚠ WARNING

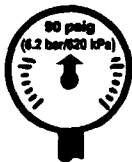

Operate at 90 p.s.i.g. (6.2 bar/620 kPa) maximum air pressure.

NOTICE

<p>⚠ WARNING</p> <p>Read the manual before operating this tool. Operate at 90 psig/6.2 bar max.</p>	
--	---

PN 48176-1 LABEL (NON-EU MODELS) **PN 49883 LABEL (-EU MODELS)**

This label must appear on the tool at all times. If it is lost or damaged, a replacement label is available at no cost.

WARNING = Hazards or unsafe practices which could result in severe personal injury, death or substantial property damage.

CAUTION = Hazards or unsafe practices which could result in minor personal injury or product or property damage.

NOTICE = Important installation, operation or maintenance information.

ROUTINE LUBRICATION REQUIREMENTS

Lack of or an excessive amount of lubrication will affect the performance and life of this tool. Use only recommended lubricants at below time intervals:

EVERY 8 HOURS OF TOOL OPERATION – Fill lubricator reservoir of recommended F.R.L. with spindle oil (29665). If an in line or air line lubricator is not used, apply several drops of spindle oil (29665) in air inlet.

EVERY 160 HOURS OF TOOL OPERATION – Lubricate clutch parts with molybdenum grease (40036-1). Lubricate gearing. Pack bearings, coat shafts and lubricate gears with NLGI #1 "EP" grease (33153). Gearing should contain approximately 1/8 oz. (3.5 g) of grease per reduction.

AIR SUPPLY REQUIREMENTS

For maximum operating efficiency, the following air supply specifications should be maintained to this air tool:

- AIR PRESSURE – 90 p.s.i.g. (6.2 bar)
- AIR FILTRATION – 50 micron
- LUBRICATED AIR SUPPLY
- HOSE SIZE – 5/16" (8 mm) I.D.

An ARO® model C28231-810 air line FILTER/REGULATOR/LUBRICATOR (F.R.L.) is recommended to maintain the above air supply specifications.

RECOMMENDED LUBRICANTS

After disassembly is complete, all parts, except sealed or shielded bearings, should be washed with solvent. To relubricate parts, or for routine lubrication, use the following recommended lubricants:



Where Used	ARO Part #	Description
Air Motor	29665	1 qt Spindle Oil
"O" Rings & Lip Seals	36460	4 oz. Stringy Lubricant
Gears and Bearings	33153	5 lb. "EP" - NLGI #1 Grease
Clutches	40036-1	1 lb. "EP" Molybdenum Disulfide

INSPECTION, MAINTENANCE AND INSTALLATION

Disconnect air supply from the tool or shut off air supply and exhaust (drain) line of compressed air before performing maintenance or service to the tool.

It is important that the tools be serviced and inspected at regular intervals for maintaining safe, trouble-free operation of the tool.

Be sure the tool is receiving adequate lubrication, as failure to lubricate can create hazardous operating conditions resulting from excessive wear.

Be sure that the air supply lines and connectors are of proper size to provide a sufficient quantity of air to the tool.

Tool maintenance and repair shall be performed by authorized, trained, competent personnel. Tools, hose and fittings shall be replaced if unsuitable for safe operation and responsibility should be assigned to be sure that all tools requiring guards or other safety devices shall be kept in legible condition. Maintenance and repair records should be maintained on all tools. Frequency of repair and the nature of the repairs can reveal unsafe application. Scheduled maintenance by competent authorized personnel should detect any mistreatment or abuse of the tool and worn parts. Corrective action should be taken before returning the tool for use.

Disassembly should be done on a clean work bench with a clean cloth spread to prevent the loss of small parts. After disassembly is completed, all parts should be thoroughly washed in a clean solvent, blown dry with air and inspected for wear levels, abuse and contamination. Double sealed or shielded bearings should never be placed in solvent unless a good method of re-lubricating the bearing is available. Open bearings may be washed but should not be allowed to spin while being blown dry.

Upon reassembling, lubricate parts where required. Use 33153 grease, or equivalent, in bearings. Use 36460 lubricant for "O" ring assembly. When assembling "O" rings or parts adjacent "O" rings, care must be exercised to prevent damage to the rubber sealing surfaces. A small amount of grease will usually hold steel balls and other small parts in place while assembling.

When replacement parts are necessary, consult drawing containing the part for identification.

Always use clean, dry air. Dust, corrosive fumes and/or excessive moisture can damage the motor of an air tool. An air line filter can greatly increase the life of an air tool. The filter removes rust, scale, moisture and other debris from the air lines. Low air pressure (less than 90 p.s.i.g.) reduces the speed of the air tool. High air pressure (more than 90 p.s.i.g.) raises performance beyond the rated capacity of the tool and could cause injury. Shown below is a typical piping arrangement.

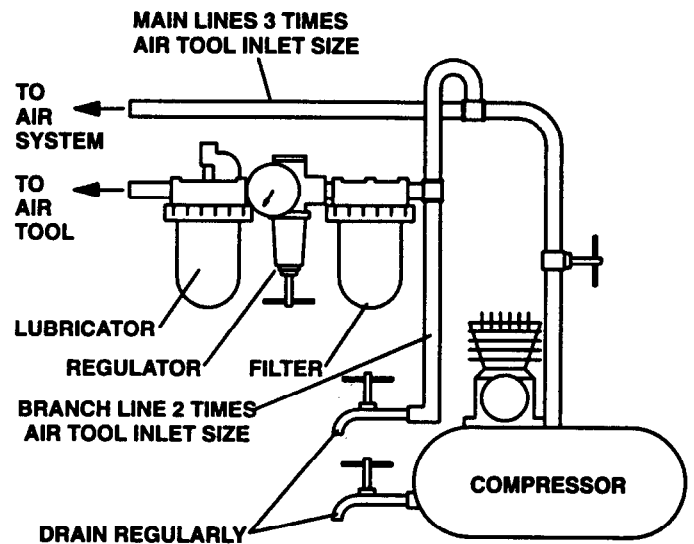

MODEL IDENTIFICATION

MODEL NUMBER	R.P.M.	CLUTCH ASSEMBLY	CLUTCH HOUSING ASSEMBLY	AUXILIARY GEARING	DRIVE GEARING	MOTOR ASSEMBLY	PISTOL GRIP ASSEMBLY	GEARING RED.
8506-APR-A	600	36310	36788	33837	36327	33816	45463	18.9:1
8506-APR-A-EU	600	36310	36788	33837	36327	33816	49889	18.9:1
8506-APR-P	600	37017	37025	33837	36327	33816	45463	18.9:1
8506-APR-T	600	38311-1	38312-2	33837	36327	33816	45463	18.9:1
8509-APR-A	900	36310	36788	33853	36327	33816	45463	11.56:1
8509-APR-A-EU	900	36310	36788	33853	36327	33816	49889	11.56:1
8509-APR-P	900	37017	37025	33853	36327	33816	45463	11.56:1
8509-APR-T	900	38311-1	38312-2	33853	36327	33816	45463	11.56:1
8515-APR-A	1500	36310	36788		36329	33811	45463	6.86:1
8515-APR-P	1500	37017	37025		36329	33811	45463	6.86:1
8521-APR-A	2100	36310	36788		36324	33816	45463	5.56:1
8521-APR-A-EU	2100	36310	36788		36324	33816	49889	5.56:1
8521-APR-P	2100	37017	37025		36324	33816	45463	5.56:1

■ CANCELLED

MODELS WITH -EU SUFFIX ARE "EC" COMPLIANT MODELS.

NOTE: GENERAL PURPOSE WRENCH 37167 FURNISHED WITH -A AND -T MODELS.

DISASSEMBLY AND ASSEMBLY OF TOOLS

Disconnect air supply from tool or shut off air supply and exhaust (drain) line of compressed air before performing maintenance or service to tool.

Before starting to disassemble or assemble this tool (any part or completely), be sure to read "Inspection, Maintenance and Installation" section.

To minimize the possibility of parts damage and for convenience, the steps for disassembly or assembly listed on the following pages are recommended.

The basic sections and instructions for removing them from the tool are as follows:

DRIVE SECTION

Remove clutch housing from tool (left hand threads); grasp clutch assembly and pull from gearing.

GEARING SECTION

Remove drive section. Hold motor housing in a suitable fixture or strap wrench and remove gearing using a wrench on flats of ring gear.

MOTOR SECTION

Motor may be removed from housing after removal of gearing.

TYPICAL CROSS SECTION OF TOOL

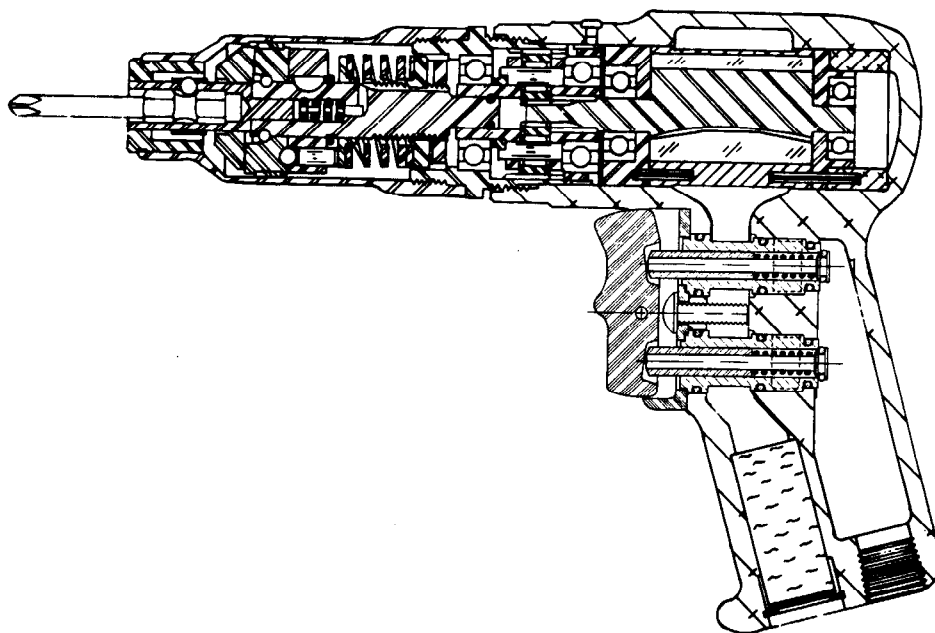

DRIVE SECTION ADJUSTABLE CLUTCH

M30
33

CLUTCH ADJUSTMENT

Remove clutch assembly (36310) from tool. Place pin in hole of jaw (36318) or wrench on square end of spindle (36311) to adjust nut (36313). To adjust properly, release nut to least tension. Tighten nut one or two positions – each click = one position. Assemble clutch to tool and test torque on fastener to be tightened. Repeat until desired torque is obtained.

DISASSEMBLY

- a. Remove clutch housing (left hand threads) and bit holder assembly (36322) from tool. Grasp clutch assembly and pull from gearing.
- b. Remove nut (36313), releasing washer (33609), clutch spring, pad (36316), pins (36317) and balls (Y16-205).
- c. Remove retaining ring (37243), releasing jaw (36318), key (36319), jaw (40772) and balls (Y16-203).

ASSEMBLY

NOTE: Lubricate balls, jaw faces, bit holder shaft, pins and thrust pad with ARO 40036-1 grease when assembling clutch. Clutch assembly should contain approximately 1/8 oz. (3.5 g) of grease.

- a. Assemble jaw (40772) to spindle (36311), aligning face of jaw with center of bearing groove in spindle. Assemble balls (Y16-203) into groove and slide jaw ahead to retain balls in groove.
- b. Assemble key (36319) and jaw (36318) to spindle and secure with retaining ring (37243). **NOTE:** Assemble jaw (36318) to spindle with small hole in face of jaw facing jaw (40772).
- c. Assemble balls (Y16-205), pins (36317), thrust pad (36316), clutch spring, washer (33609) and nut (36313). Adjust to desired tension (see "Clutch Adjustment").
- d. Assemble spring (31092), plug (31093), bit holder assembly (36322) and bit to spindle and assemble to tool. Assemble clutch housing to tool.

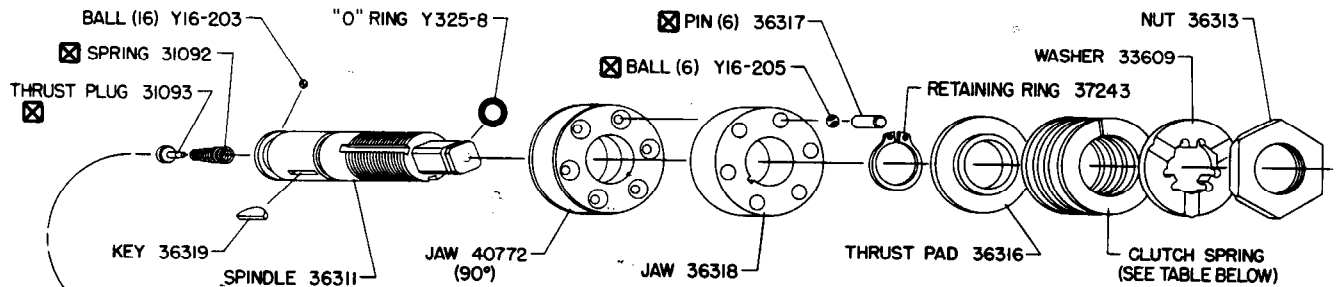

PARTS SHOWN BELOW THIS LINE ARE NOT INCLUDED IN 36310 () CLUTCH ASS'Y

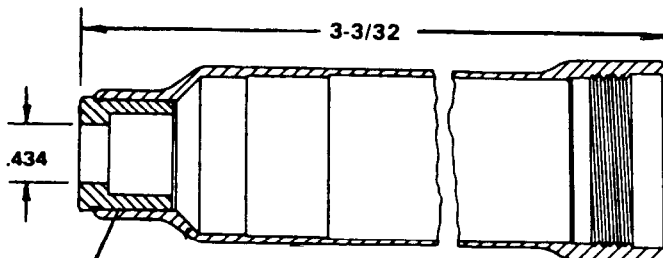
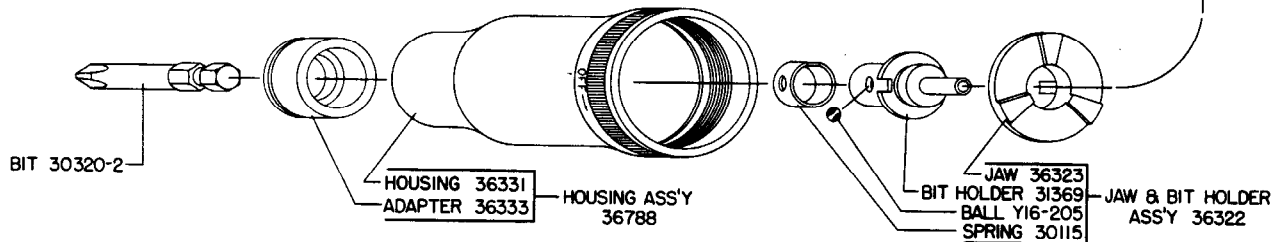

GUIDE ADAPTER IS PRESSED INTO HOUSING
SEE PAGE 14 FOR ADDITIONAL GUIDE ADAPTERS

CLUTCH ASS'Y. NO.	TYPE	CLUTCH SPRING NO.	SPRING IDENTIFICATION	
			TYPE WIRE	WIRE THICKNESS
36310-1	HIGH TORQUE	37872	FLAT	.093" x .188"
36310	MED. TORQUE	36315	FLAT	.062" x .156"
36310-2	LOW TORQUE	36512	ROUND	.080" DIAMETER

PARTS MARKED THIS ARE INCLUDED IN SERVICE KIT NO. 42114 AND/OR 42341, SEE PAGE 12.

DRIVE SECTION TORQMATIC CLUTCH

CLUTCH ADJUSTMENT

Remove clutch assembly from tool. Place wrench on square end of spindle (38322) to adjust nut (36313). To adjust properly, release nut to least tension. Tighten nut one or two positions – each click = one position. Assemble clutch to tool and test torque on fastener to be tightened. Repeat until desired torque is obtained.

DISASSEMBLY

- a. Remove clutch housing (left hand threads) and bit holder assembly (36322) from tool. Grasp clutch assembly and pull from gearing.
- b. Remove nut (36313), releasing washer (33609) and clutch spring.
- c. Remove snap ring (31124), releasing retaining ring (37241-1), retainer (38317) and spring (44668). Driver (38319) and cams (38320 and 38321) are now free to be removed, releasing steel balls (Y16-203) and pins (38325). Lockout cam (38324) and springs (38313 and 38314) are now free to be removed.
- d. Remove retaining ring (38327), releasing spacer (38316), jaw (40771) and steel balls (Y16-204).

ASSEMBLY

NOTE: Lubricate balls, pins, jaw faces, lockout cam, cams, driver and bit holder shaft with ARO 40036-1 grease when assembling

clutch. Clutch assembly should contain approximately 1/8 oz. (3.5 g) of grease.

- a. Place jaw (40771) on bench, cam face down, start spindle into jaw, assemble one row of steel balls (Y16-204) and slide to shoulder of spindle. Invert spindle and jaw, assemble balance of steel balls (Y16-204) and spacer (38316) and secure with retaining ring (38327).
- b. Assemble lockout cam (38324) and springs (38313 and 38314) into end of spindle (38322) in proper sequence.
- c. Assemble cam (38321) to spindle, tang end first. Assemble cam (38320) onto spindle until cam face is flush with groove in spindle, assemble first row of steel balls (Y16-203) into groove, slip cam ahead to second groove, assemble steel balls into second groove and slide cam ahead to secure.
- d. Assemble driver (38319) over cam (38320) until face is flush with holes in spindle, assemble pins (38325) into holes and slide drive ahead to secure.
- e. Assemble spring (44668) over shoulder of cam (38320), assemble spring retainer (38317) to spindle and secure with retainers (37241-1) and snap ring (31124).
- f. Assemble spring and washer (33609) to spindle and secure with nut (36313). Adjust to desired tension and assemble with bit holder assembly (36322) into housing.

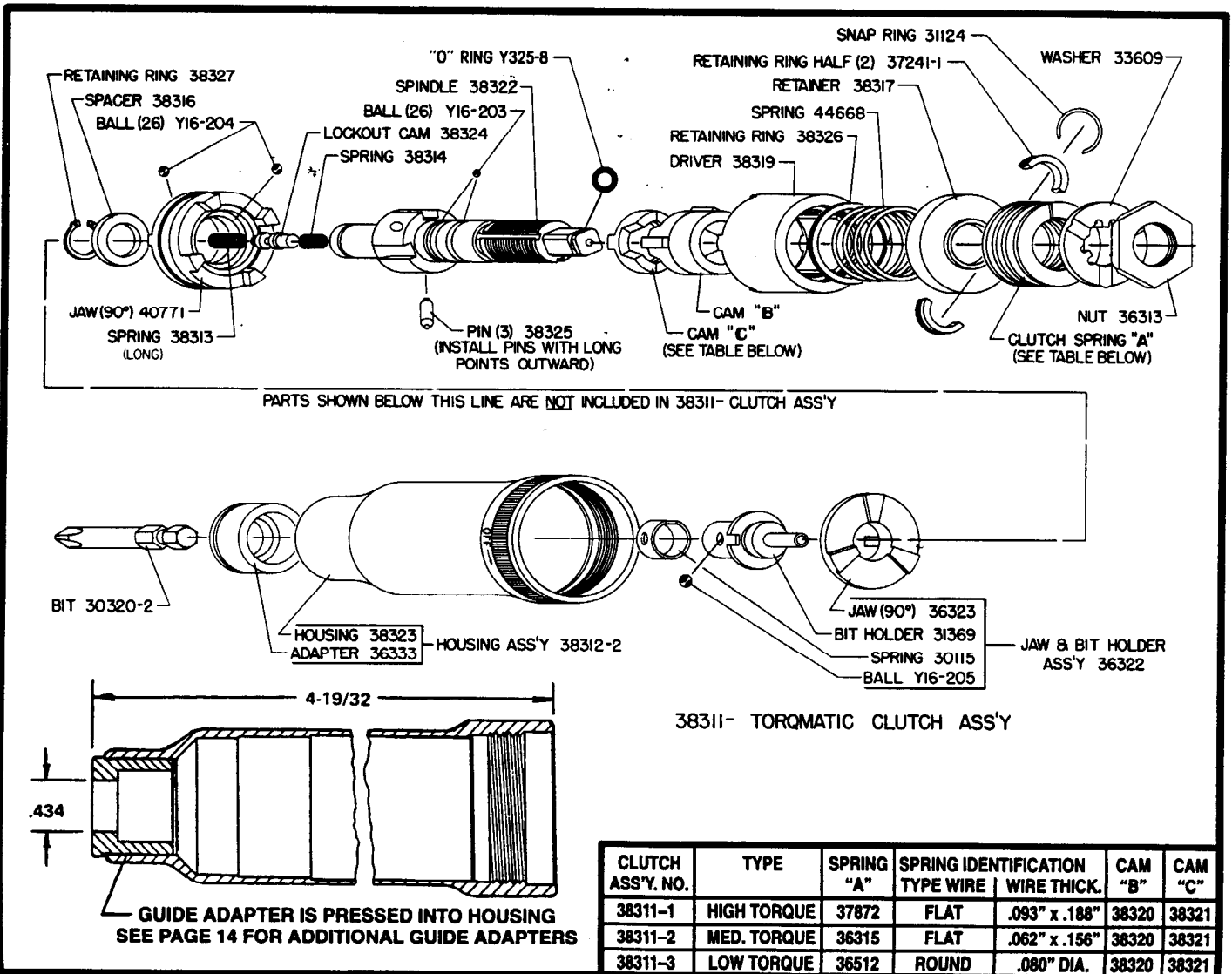

DRIVE SECTION

POSITIVE CLUTCH

M30
33

DISASSEMBLY

- a. Remove clutch housing (left hand threads) and bit holder assembly (37021) from tool. Grasp clutch assembly and pull from gearing.

should contain approximately 1/32 oz. (.9 g) of grease.

ASSEMBLY

NOTE: Lubricate bit holder shaft and faces of jaws with ARO 40036-1 grease when assembling clutch. Clutch assembly

- a. Assemble jaw (37029), spring (31092), plug (31093) and "O" ring (Y325-8) to spindle (37033).
- b. Assemble bit holder assembly (37021) to clutch assembly and assemble to tool.

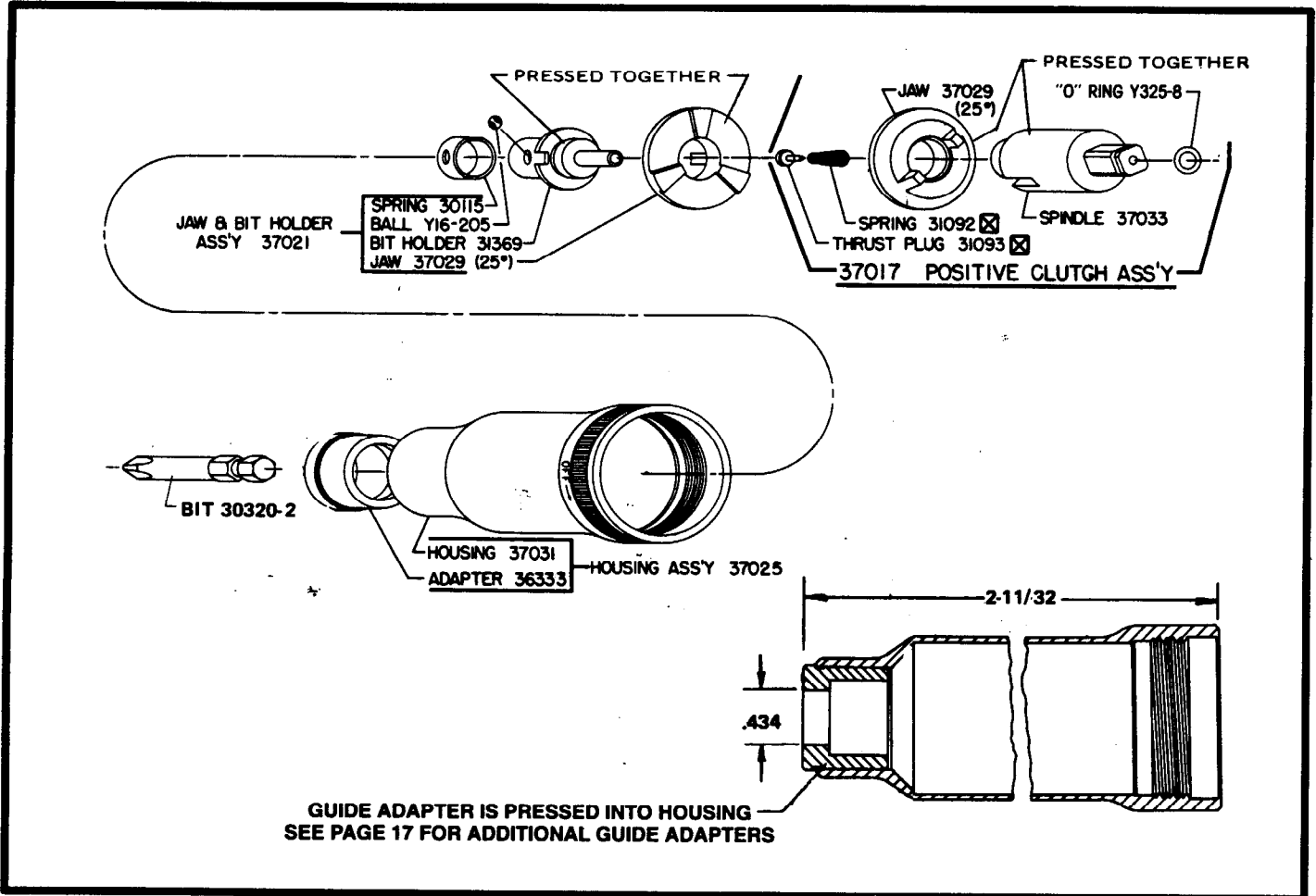

GEARING SECTION DRIVE GEARING

DISASSEMBLY

- a. Remove spindle and components from ring gear.
- b. To remove gears from spindle, remove bearing, spacer and shafts.

approximately 1/8 oz. (3.5 g) of grease.

ASSEMBLY

NOTE: Pack bearings and lubricate gears liberally with ARO 33153 grease upon assembly. Gearing assembly should contain

- a. Assemble spacer (33691 or 33693) and gears to spindle and secure with shafts, aligning notch in shafts with spacer.
NOTE: Shafts (33686) contain fifteen (15) loose needle bearings (33458) per shaft.
- b. Assemble spacer (37676), where applicable, and bearings to spindle and assemble to ring gear.

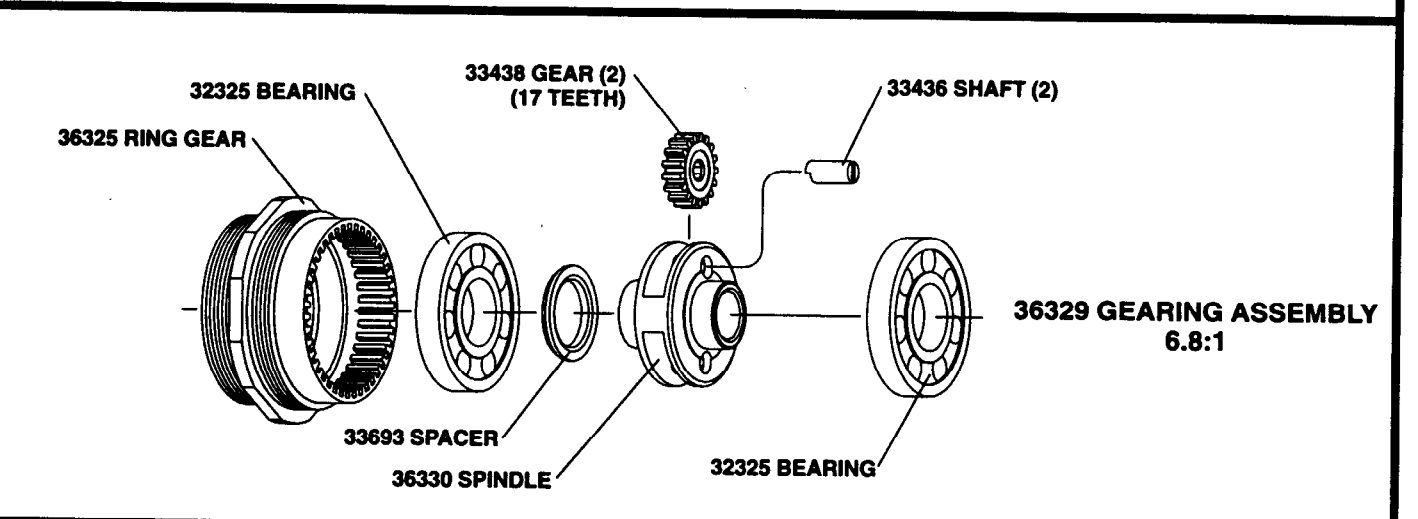
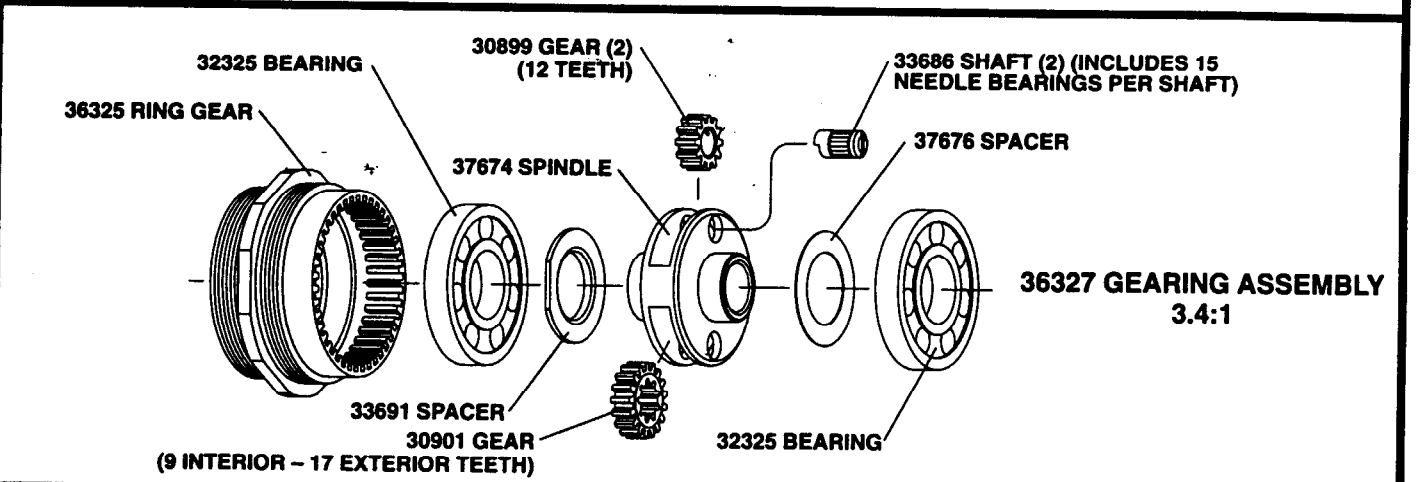
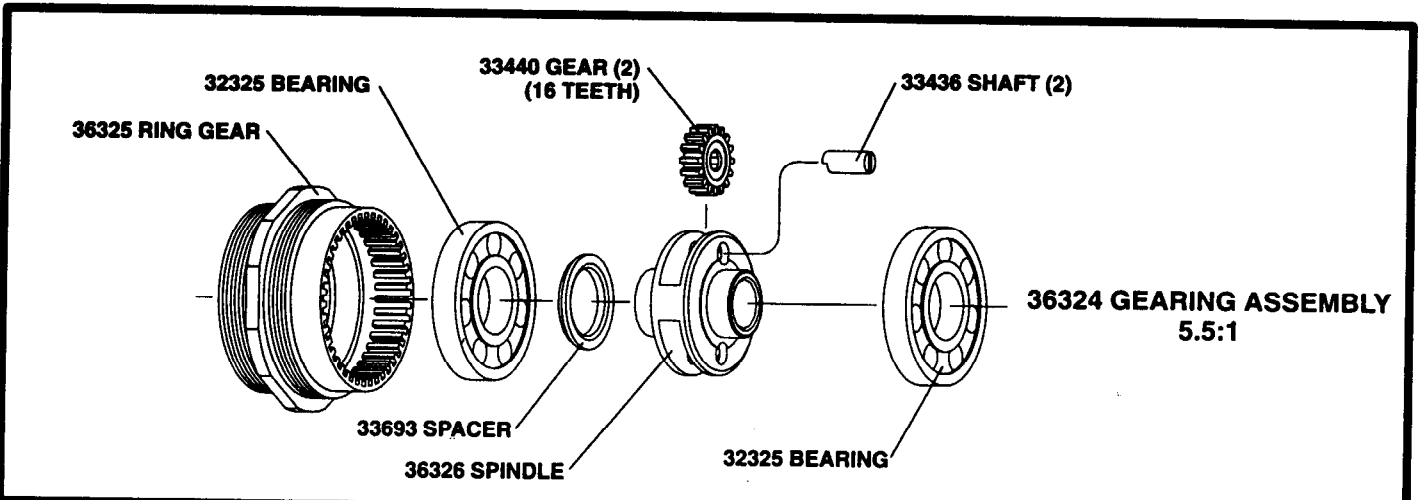

GEARING SECTION AUXILIARY GEARING

M30
33

DISASSEMBLY

- a. Grasp adapter (ring gear) in one hand and tap splined end of spindle with a soft face hammer; spindle and components will loosen from adapter.
- b. To remove gears from spindle, remove bearing, spacer and shafts.

33153 grease upon assembly. Gearing should contain approximately 1/8 oz. (3.5 g) of grease.

- a. Assemble spacer (32314 or 32312) and gears to spindle and secure with shafts, aligning notch in shafts with spacer.
NOTE: Shafts (33686) contain fifteen (15) loose needle bearings (33458) per shaft.

ASSEMBLY

NOTE: Pack bearings and lubricate gears liberally with ARO

- b. Assemble spacer (37676), where applicable, and bearings to spindle and assemble to adapter (32326).

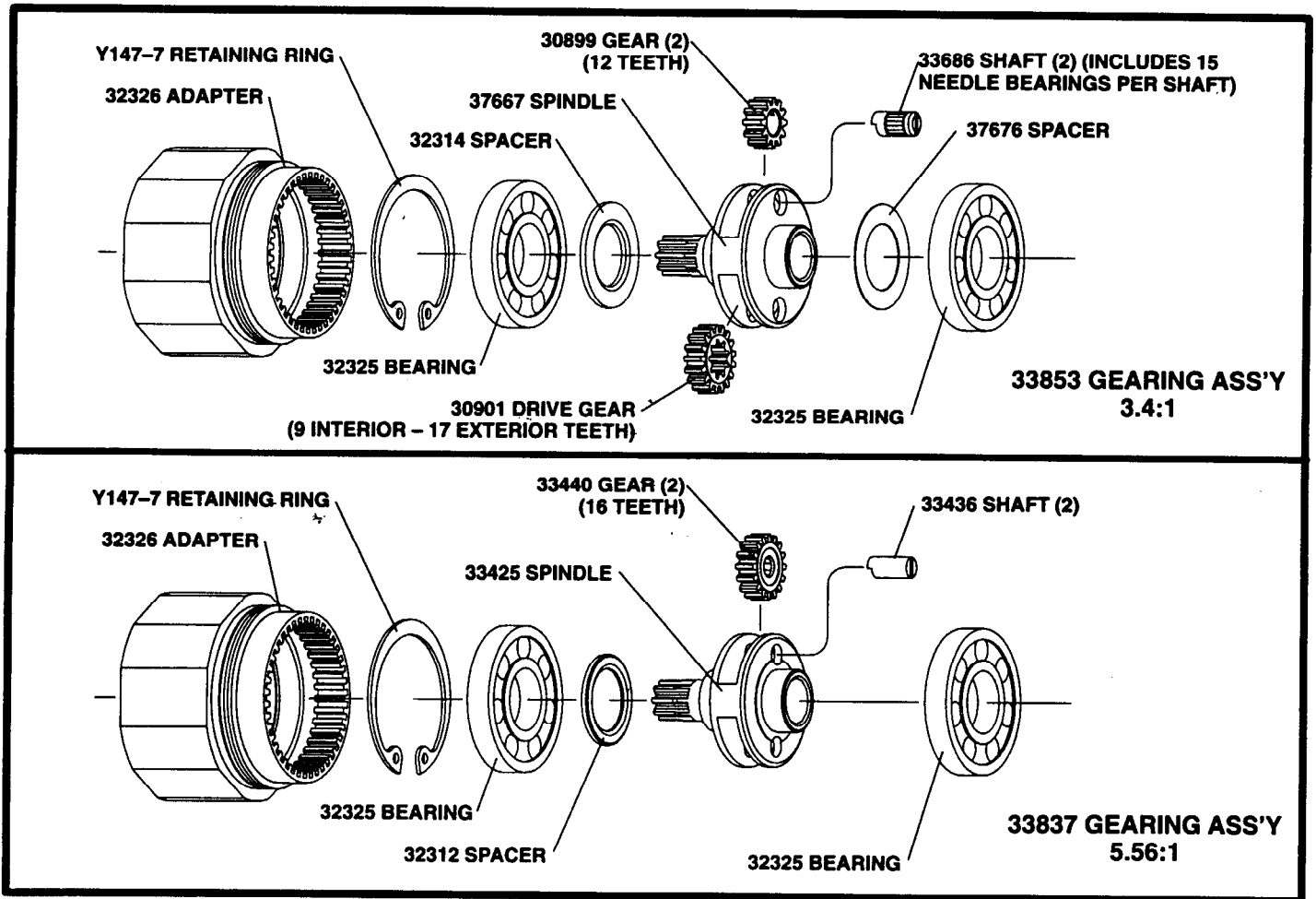

MOTOR SECTION

DISASSEMBLY

- Remove motor from housing. Grasp cylinder in one hand and tap splined end of rotor with a soft face hammer; motor will come apart.

ASSEMBLY

- Pack bearings with ARO 33153 grease and assemble bearing (Y65-7) into end plate (31601), pressing on outer race of bearing.
- Assemble end plate (31601) to rotor, pressing on inner race of bearing.
- Coat i.d. of cylinder (37684) with ARO 29665 spindle oil and

- assemble over rotor, aligning air inlet holes of cylinder with air inlet slots of end plate.
- Coat blades (31363) with ARO 29665 spindle oil and assemble to rotor slots – straight side out.
- Assemble bearing (Y65-15) to end plate (31602), pressing on outer race of bearing.
- Assemble end plate (31602) to cylinder, aligning roll pin in cylinder with hole in end plate.
- Be sure rotor does not bind (if rotor binds, tap splined end lightly with a soft face hammer to loosen) and assemble motor to housing with locating pin (32814) and porting block (45471).
- Assemble spacers (32310 and 32305) and gearing to tool.

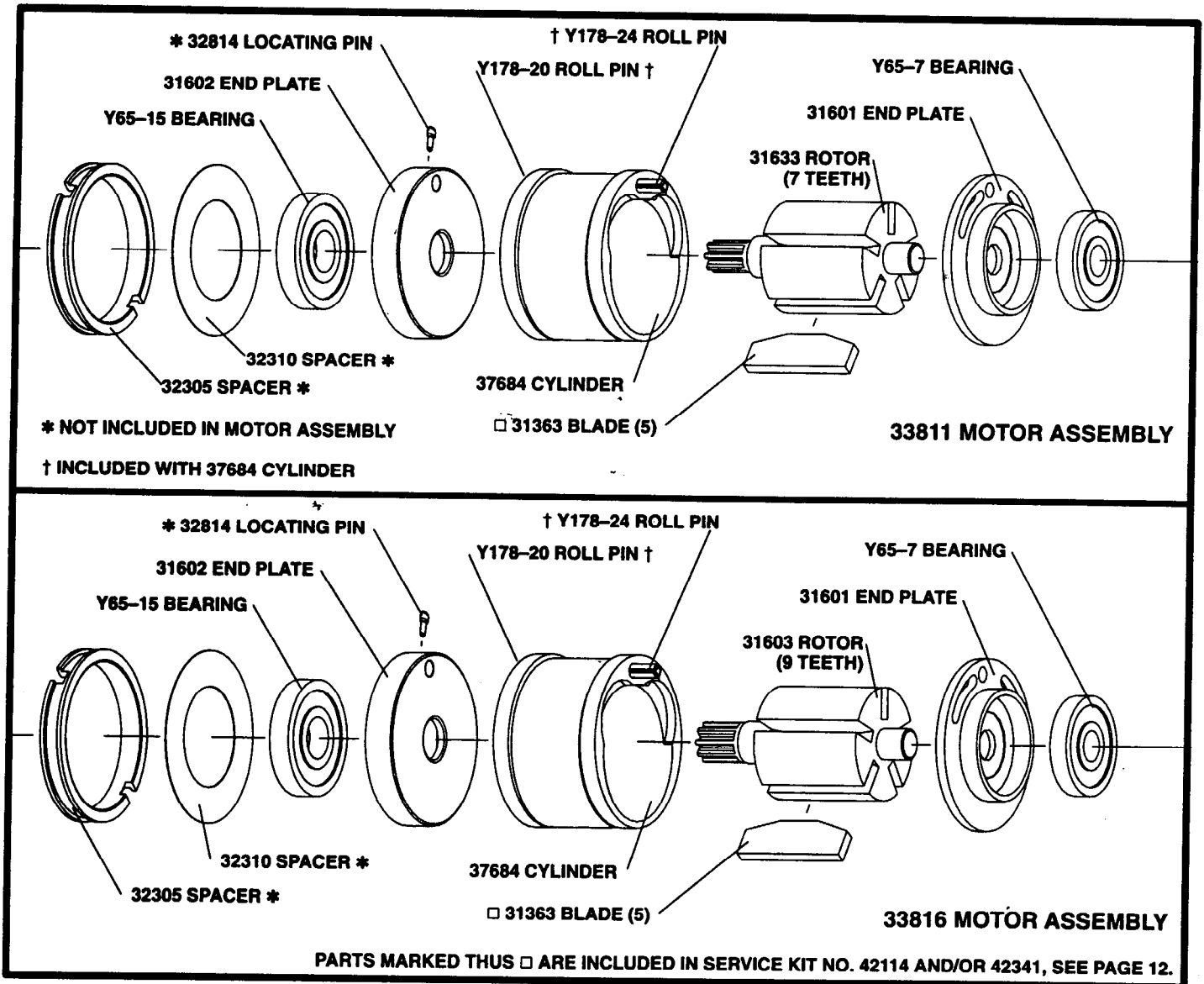

DISASSEMBLY

- Remove roll pin (Y178-25), releasing trigger (45469).
- Remove screw (Y222-156-C), releasing shroud (45468).
- Grasp end of valve assembly (47880) and pull to remove valve assembly and bushing (45465).
- Remove retaining ring (Y147-68), releasing screens (42911) and muffler (45474).

ASSEMBLY

NOTE: Whenever a part containing "O" rings has been removed from the tool, it is recommended the "O" rings be replaced. Grease all "O" rings before assembly.

- Assemble "O" rings (Y325-13, Y325-12 and Y325-11) to

- bushings (45465).
- Assemble "O" ring (Y325-7) to valve assembly (47880).
- Lubricate plunger (47879) and valve assembly (47880) with ARO 29665 spindle oil.
- Assemble springs (48806-1) to valve assembly (47880).
- Assemble plungers (47879) and valve assemblies (47880) to bushings (45465) and assemble bushings to housing, aligning flats of bushings with flats of shroud.
- Assemble shroud (45468) to housing, securing with screw (Y222-156-C).
- Assemble trigger to shroud, securing with roll pin (Y178-25).
- Assemble muffler (45474) and screens (42911) to housing, securing with retaining ring (Y147-68).

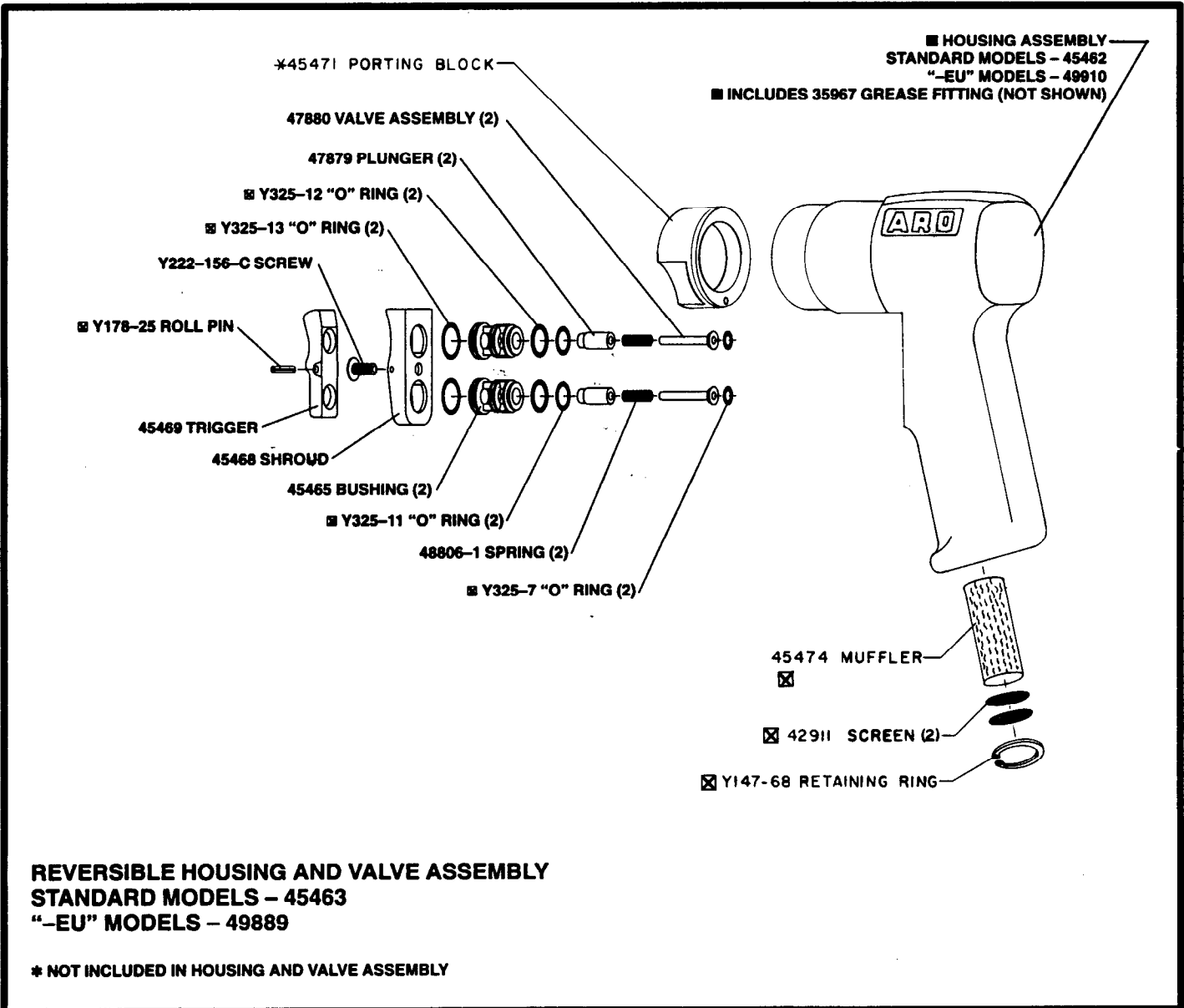

PARTS MARKED THUS ■ ARE INCLUDED IN SERVICE KIT NO. 42114 AND/OR 42341, SEE PAGE 12.

SERVICE KIT NO. 42114
FOR SERVICING ADJUSTABLE CLUTCH MODELS

<u>QTY</u>	<u>PART NUMBER</u>	<u>DESCRIPTION</u>	<u>QTY</u>	<u>PART NUMBER</u>	<u>DESCRIPTION</u>
1	31092	SPRING	6	Y16-205	BALL
1	31093	THRUST PIN	1	Y147-68	RETAINING RING
5	31363	BLADE	1	Y178-25	ROLL PIN
6	36317	PIN	2	Y180-13	"E" RETAINING RING
1	41795	MOTOR OIL	2	Y325-7	"O" RING
1	41799	GEAR LUBE	2	Y325-11	"O" RING
1	41954	"O" RING LUBE	2	Y325-12	"O" RING
2	42911	SCREEN	2	Y325-13	"O" RING
1	45474	MUFFLER			

SERVICE KIT NO. 42341
FOR SERVICING DIRECT DRIVE AND POSITIVE CLUTCH MODELS

<u>QTY</u>	<u>PART NUMBER</u>	<u>DESCRIPTION</u>	<u>QTY</u>	<u>PART NUMBER</u>	<u>DESCRIPTION</u>
1	31092	SPRING	1	Y147-68	RETAINER RING
1	31093	THRUST PIN	1	Y178-25	ROLL PIN
5	31363	BLADE	2	Y180-13	"E" RING
1	41795	MOTOR OIL	2	Y325-7	"O" RING
1	41799	GEAR LUBE	2	Y325-11	"O" RING
1	41954	"O" RING LUBE	2	Y325-12	"O" RING
2	42911	SCREEN	2	Y325-13	"O" RING
1	45474	MUFFLER			

TROUBLE SHOOTING

LISTED BELOW ARE SOME OF THE MOST COMMON CAUSES FOR THE SCREWDRIVER TO MALFUNCTION. MALFUNCTIONS BEYOND THE SCOPE OF THIS MANUAL SHOULD BE BROUGHT TO THE ATTENTION OF YOUR ARO REPRESENTATIVE OR RETURN THE TOOL TO THE FACTORY FOR REPAIR.

<u>CONDITION</u>	<u>POSSIBLE CAUSE</u>	<u>CORRECTIVE ACTION</u>
LOW SPEED OR FAILURE TO OPERATE.	1. INADEQUATE AIR SUPPLY.	1. CHECK AIR SUPPLY FOR CORRECT REGULATOR ADJUSTMENT (90 P.S.I.G. MAX. WHEN TOOL IS OPERATING).
	2. CLOGGED AIR INLET, BADLY WORN OR DAMAGED THROTTLE COMPONENTS OR CLOGGED MUFFLER.	2. DISASSEMBLE, CLEAN, INSPECT THROTTLE COMPONENTS, REPLACE WORN OR DAMAGED PARTS. REFER TO PAGE 11.
	3. IMPROPER LUBRICATION OF UNIT (MOTOR AND/OR GEARING), DIRTY MOTOR (ROTOR BLADES STICKING, ETC.), OR BROKEN OR BADLY WORN ROTOR BLADES OR BEARINGS IN MOTOR.	3. BE SURE LUBRICATOR IS FULL OF OIL AND GEARING IS LUBRICATED REGULARLY, REFER TO PAGE 3. DISASSEMBLE, CLEAN, INSPECT, REPLACE WORN OR DAMAGED PARTS, LUBRICATE.
	4. BADLY WORN OR DAMAGED CLUTCH COMPONENTS.	4. DISASSEMBLE CLUTCH. CLEAN, INSPECT, REPLACE WORN OR DAMAGED PARTS, LUBRICATE.
CLUTCH DISENGAGES TOO SOON OR FAILURE OF CLUTCH TO DISENGAGE.	1. IMPROPER CLUTCH ADJUSTMENT.	1. REFER TO CLUTCH ADJUSTMENT, PAGES 5 AND 6.
	2. BADLY WORN OR DAMAGED CLUTCH COMPONENTS.	2. DISASSEMBLE CLUTCH, CLEAN, INSPECT, REPLACE WORN OR DAMAGED PARTS, LUBRICATE. REFER TO PAGES 5 AND 6.

44361-() PIPED EXHAUST SYSTEM ASSEMBLY

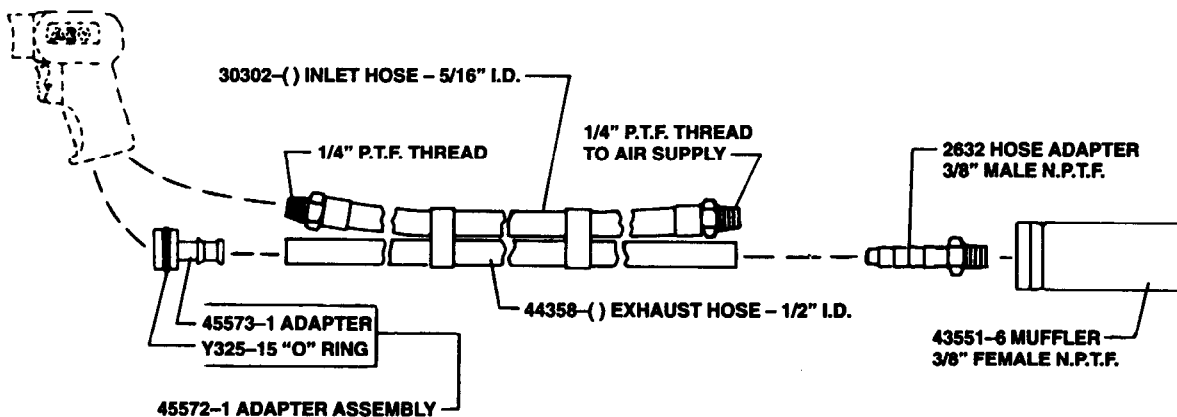

PIPED EXHAUST ASSEMBLY CONSISTS OF 5/16" I.D. AIR INLET HOSE WITH 1/4" MALE FITTING AT EACH END, 1/2" I.D. EXHAUST HOSE, 45572-1 ADAPTER ASSEMBLY AND 2632 BARBED INSERT WITH 3/8" MALE THREAD.

TO ORDER PIPED EXHAUST SYSTEM ASSEMBLY: ADD DASH NUMBER TO PART NUMBER TO INDICATE DESIRED LENGTH OF HOSE IN FEET. EXAMPLE: 44361-20, THE -20 INDICATES 20 FEET OF HOSE. ORDER LENGTH DESIRED UP TO 30 FEET MAXIMUM.

TO ASSEMBLE ADAPTER TO TOOL: REMOVE RETAINING RING (Y147-68), 2 SCREENS (42911) AND MUFFLER (45474) FROM TOOL. INSERT ADAPTER (45572-1) INTO HOUSING UNTIL IT BOTTOMS IN HOUSING AND SECURE WITH RETAINING RING (Y147-68). THREAD INLET HOSE TO TOOL AND TIGHTEN SO EXHAUST HOSE ALIGNS WITH ADAPTER (45572) AND SLIP EXHAUST HOSE OVER ADAPTER. NO CLAMP IS NEEDED TO SECURE HOSE TO ADAPTER SINCE EXHAUST PRESSURE IS VERY LOW.



37526 AIR REGULATOR

CAN BE USED ON THE "QRT" SCREWDRIVER AS AN IN-LINE REGULATOR. HAS 1/4" MALE N.P.T.F. AND 1/4" FEMALE N.P.T.F. INLET FOR AIR HOSE.

ACCESSORIES

HOUSING AND ADAPTER ASSEMBLIES

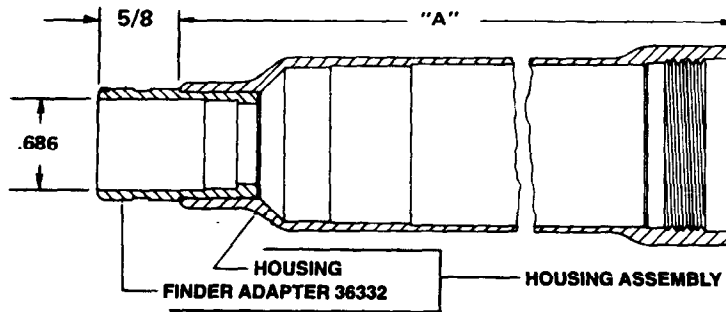

FINDER ADAPTER IS PRESSED INTO HOUSING.

HOUSING AND FINDER ADAPTER - USE WITH FINDERS 36106-(), 36105-(), 41291-() AND 41292-(). ALSO USE WITH GUIDES 30334-(), 40261 AND 41767. ALSO FOR USE WITH BALL LOCK ADAPTER ASSEMBLY 44589 WITHOUT USE OF GUIDE BUSHING.

ASSEMBLY NUMBER	HOUSING	DIMENSION "A"	CLUTCH USED ON
36786	36331	3"	ADJUSTABLE
38312-1	38323	4-1/2"	TORQMATIC
37023	37031	2-1/4"	POSITIVE
37023	37031	2-1/4"	DIRECT DRIVE

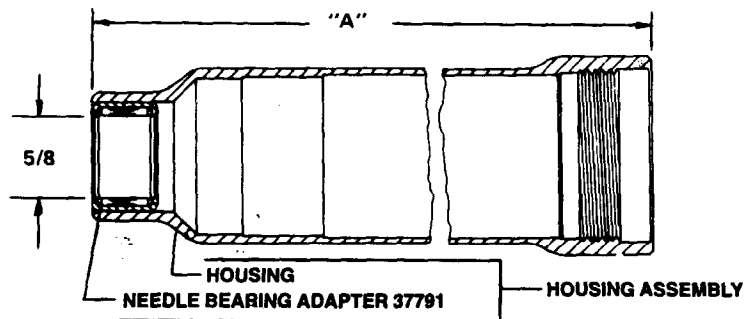

NEEDLE BEARING ADAPTER IS PRESSED INTO HOUSING.

FOR USE WITH 37792-4 BALL LOCK ASSEMBLY AND 38815-2 AND 38815-4 SQUARE DRIVE ASSEMBLIES, PAGE 17.

ASSEMBLY NUMBER	HOUSING	DIMENSION "A"	CLUTCH USED ON
36788-1	36331	3"	ADJUSTABLE
38312-3	38323	4-1/2"	TORQMATIC
37025-1	37031	2-1/4"	POSITIVE
37025-1	37031	2-1/4"	DIRECT DRIVE

FINDERS

STANDARD LENGTH FOR 1/4" HEX BITS

NOTE: SPRING 30111 AND LOCK SPRING 31574 REQUIRED FOR USE WITH FINDERS (ORDER SEPARATELY). USE WITH FINDER ADAPTER 36332.

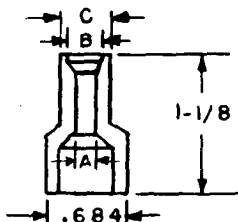

FINDER NO.	SCREW SIZE	"A"	"B"	"C"	USE BIT NO.
36106-1	1F 2R	.125"	.149"	.218"	30145-1
36106-2	2F 3R	.141"	.180"	.250"	30145-2
36106-3	3F 4R	.159"	.211"	.281"	30145-3
36106-4	4F 5R	.190"	.228"	.296"	30145-4
36106-5	5F 6R	.220"	.255"	.343"	30145-5
36106-6	6F 7R	.253"	.282"	.359"	30145-6
36106-7	7F 8R	.253"	.308"	.375"	30145-6
36106-8	8F 10R	.280"	.335"	.406"	30145-8
36106-10	10F 12R	.315"	.388"	.468"	30145-10
36106-12	12F 14R	.363"	.450"	.531"	30145-12

FINDERS

EXTENSION FINDER FOR 1/4" HEX BITS



NOTE: SPRING 30111 AND LOCK SPRING 31574 REQUIRED FOR USE WITH FINDERS (ORDER SEPARATELY). USE WITH FINDER ADAPTER 36332.

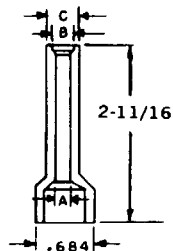

FINDER NO.	SCREW SIZE	"A"	"B"	"C"	USE BIT NO.
36105-1	1F 2R	.125"	.149"	.250"	31370-1
36105-2	2F 3R	.141"	.180"	.250"	31370-2
36105-3	3F 4R	.159"	.211"	.281"	31370-3
36105-4	4F 5R	.190"	.228"	.296"	31370-4
36105-5	5F 6R	.220"	.255"	.359"	31370-5
36105-6	6F 8R	.253"	.300"	.375"	31370-6
36105-8	8F 10R	.280"	.335"	.406"	31370-8
36105-10	10F 12R	.315"	.388"	.468"	31370-10
36105-12	12F 14R	.363"	.450"	.531"	31370-12

BELL MOUTH FINDER FOR 1/4" HEX BITS

Similar to standard finders, except that each finder will accept more sizes and types of screw heads.



NOTE: SPRING 30111 AND LOCK SPRING 31574 REQUIRED FOR USE WITH FINDERS (ORDER SEPARATELY). USE WITH FINDER ADAPTER 36332.

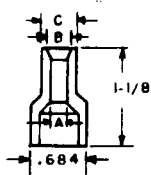

FINDER NO.	SCREW SIZE	"A"	"B"	"C"	USE BIT NO.
41291-1	1 - 3	.125"	.187"	.265"	30145-1
41291-2	3 - 4	.141"	.218"	.296"	30145-2
41291-3	4 - 6	.159"	.281"	.359"	30145-3
41291-4	5 - 8	.190"	.312"	.390"	30145-4
41291-5	7 - 9	.253"	.343"	.421"	30145-6
41291-6	8 - 10	.253"	.375"	.453"	30145-7
41291-7	10 - 12	.280"	.437"	.484"	30145-8

BELL MOUTH EXTENSION FINDER FOR 1/4" HEX BITS

Similar to standard finders, except that each finder will accept more sizes and types of screw heads.



NOTE: SPRING 30111 AND LOCK SPRING 31574 REQUIRED FOR USE WITH FINDERS (ORDER SEPARATELY). USE WITH FINDER ADAPTER 36332.

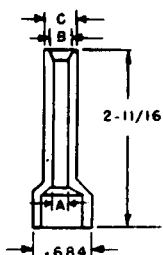

FINDER NO.	SCREW SIZE	"A"	"B"	"C"	USE BIT NO.
41292-1	1 - 3	.125"	.187"	.265"	31370-1
41292-2	3 - 4	.141"	.218"	.296"	31370-2
41292-3	4 - 6	.159"	.281"	.359"	31370-3
41292-4	5 - 8	.190"	.312"	.390"	31370-4
41292-5	7 - 9	.253"	.343"	.421"	31370-6
41292-6	8 - 10	.253"	.375"	.453"	31370-6
41292-7	10 - 12	.280"	.437"	.484"	31370-8

BITS AND BIT HOLDERS

1/4" HEX DRIVE BITS

STANDARD LENGTH
BLADED BITS FOR
SLOTTED SCREWS.



PART NO.	LENGTH	SCREW SIZE	SHAFT DIA.
30145-1	1-15/16"	1F - 2R	.122"
30145-2		2F - 3R	.134"
30145-3		3F - 4R	.154"
30145-4		4F - 5R	.187"
30145-5		5F - 6R	.215"
30145-6		6F - 7R	.250"
30145-7		7F - 8R	.250"
30145-8		8F - 10R	.275"
30145-10		10F - 12R	.312"
30145-12		12F - 14R	.360"

ACCESSORIES

BITS AND BIT HOLDERS

1/4" HEX DRIVE BITS

**EXTENSION BLADED BITS
FOR SLOTTED SCREWS.**

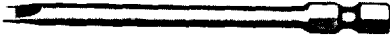

PART NO.	LENGTH	SCREW SIZE	SHAFT DIA.
31370-2	3-1/2"	2F - 3R	.134"
31370-3		3F - 4R	.154"
31370-4		4F - 5R	.187"
31370-5		5F - 6R	.215"
31370-6		6F - 7R	.250"
31370-7		5F - 6R	.250"
31370-8		8F - 10R	.275"
31370-10		10F - 12R	.312"
31370-12		12F - 14R	.360"

PHILLIPS BITS



PART NO.	LENGTH	POINT SIZE	SHAFT DIA.
30320-1	1-15/16"	1	.182"
30320-2	1-15/16"	2	.246"
30320-3	1-15/16"	3	.310"
31531-1	2-3/4"	1	.182"
31531-2	2-3/4"	2	.246"
31531-3	2-3/4"	3	.310"

REED & PRINCE BITS



PART NO.	LENGTH	POINT SIZE	SHAFT DIA.
30776-1	1-15/16"	1/4	.250"
30776-2	2-3/4"	1/4	.250"

POSI-DRIVE BITS



PART NO.	LENGTH	POINT SIZE	SHAFT DIA.
41279-1	1-15/16"	1	.182"
41279-2	1-15/16"	2	.246"
41279-3	1-15/16"	3	.310"

**EXTENDED BIT WITH INTEGRAL
FINDER FOR SLOTTED SCREWS.**



PART NO.	LENGTH	SCREW SIZE	SHAFT DIA.
30351-5	3-23/32"	5F - 6R	.193"
30351-6	3-23/32"	6F - 8R	.241"
30351-8	3-23/32"	8F - 10R	.290"
30351-10	3-29/32"	10F - 12R	.350"
30382-5	6-23/32"	5F - 6R	.193"
30382-6	6-23/32"	6F - 8R	.241"
30382-8	6-23/32"	8F - 10R	.290"
30382-10	6-25/32"	10F - 12R	.350"

INSERT BITS



PART NO.	LENGTH	POINT SIZE	SHAFT
31151-1	1"	#1 Phillips	1/4" Hex
31151-2	1"	#2 Phillips	1/4" Hex
31151-3	1"	#3 Phillips	1/4" Hex
31148	1-1/8"	#6 & Larger	1/4" Hex
41280-1	1"	#1 Posidriv	1/4" Hex
41280-2	1"	#2 Posidriv	1/4" Hex
41280-3	1"	#3 Posidriv	1/4" Hex

INSERT BIT HOLDER

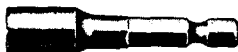

PART NO.	LENGTH	SHAFT DIA.	SHAFT
31150	2-1/8"	.312"	1/4" Hex

ACCESSORIES

BITS AND BIT HOLDERS

M30
33

SOCKET HEAD DRIVERS



PART NO.	LENGTH	HEX SIZE	SET SCREW SIZE	CAP SCREW SIZE	SHAFT DIA.
30370-2	1-15/16"	3/32"	#10 - #12	#4 - #5	.187"
30370-3		1/8"	1/4		.187"
30370-4		5/32"	5/16	#10	.187"
30370-5		3/16"	3/8	1/4	.250"
30370-6		7/32"	7/16		.250"
30370-7		1/4"	1/2	5/16	.312"
30370-8		7/64"		#6	.187"
30370-9		9/64"		#8	.187"

MAGNETIC BIT HOLDER

USE WITH GUIDE BUSHING 40261.



SQUARE DRIVE ADAPTERS

USE WITH GUIDE BUSHING 30334-().



HEX BALL LOCK ADAPTER

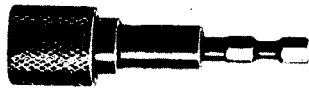

PART NO.	LENGTH	BIT SIZE	SHAFT DIA.
40259	2-31/32"	1/4" Hex	7/16"

PART NO.	LENGTH	SQ. DRIVE	SHANK DIA.
32988-2	2"	1/4"	.312"
30337-2	2"	9/32"	.375"
30337-3	2"	3/8"	.312"
32988-4	4"	1/4"	.360"
30337-4	4"	9/32"	.375"
32988-6	6"	1/4"	.312"

PART NO.	LENGTH	BIT SIZE	USE GUIDE NO.
41764	2-3/4"	1/4" Hex	41767
41765	2-3/4"	1/4" Hex	41767
44589	2-3/8"	1/4" Hex	NONE

NOTE: 41764 - PULL SLEEVE TO RELEASE BIT.
 41765 - PUSH SLEEVE TO RELEASE BIT.
 44589 - PULL SLEEVE TO RELEASE BIT. USE WITH HOUSING ASSEMBLY 36786 WITHOUT GUIDE BUSHING.

GUIDE BUSHINGS

USE WITH FINDER ADAPTER 36332 AND LOCK SPRING 31574.

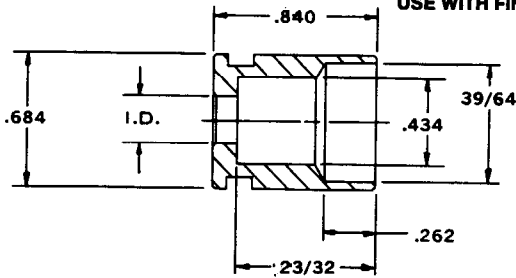

30334-() GUIDE BUSHING (STEEL)

PART NO.	I.D.
30334-1	.252"
30334-2	.383"
30334-3	.453"
30334-4	.189"
30334-5	.320"

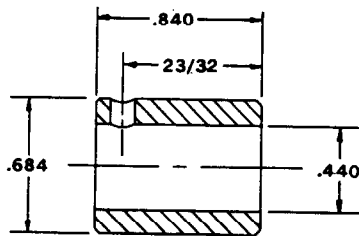

GUIDE BUSHING 40261 (BRONZE)

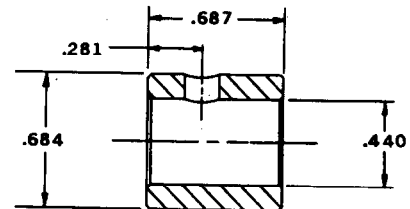

GUIDE BUSHING 41767 (BRONZE)



Part of worldwide Ingersoll-Rand

PN 49999-032