

BRONZE PEDESTAL RUBBER IMPELLER PUMP

DIMENSIONS

501M-05 & 501M-06

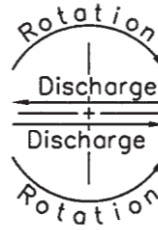
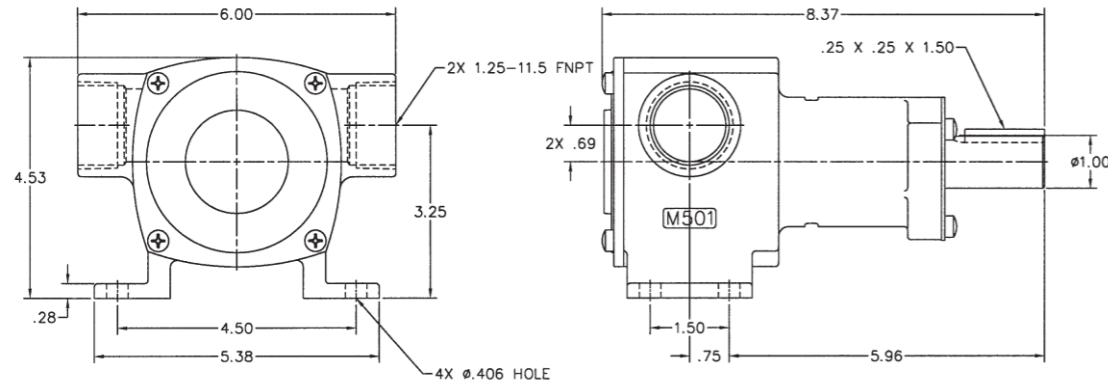

501M-05 & 501M-06 WITH ELECTRIC CLUTCH

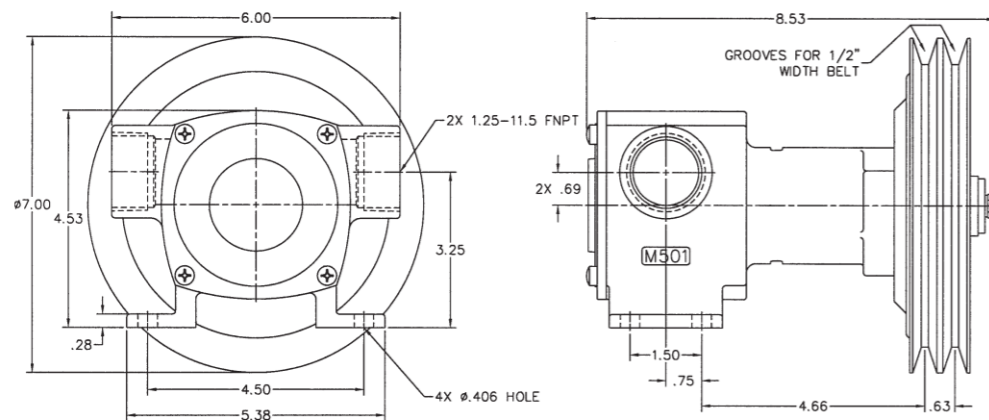

DIMENSIONS
501M-05 & 501M-06
w/ ELECTRIC CLUTCH

501-07

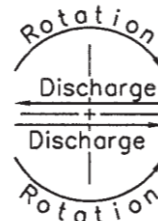
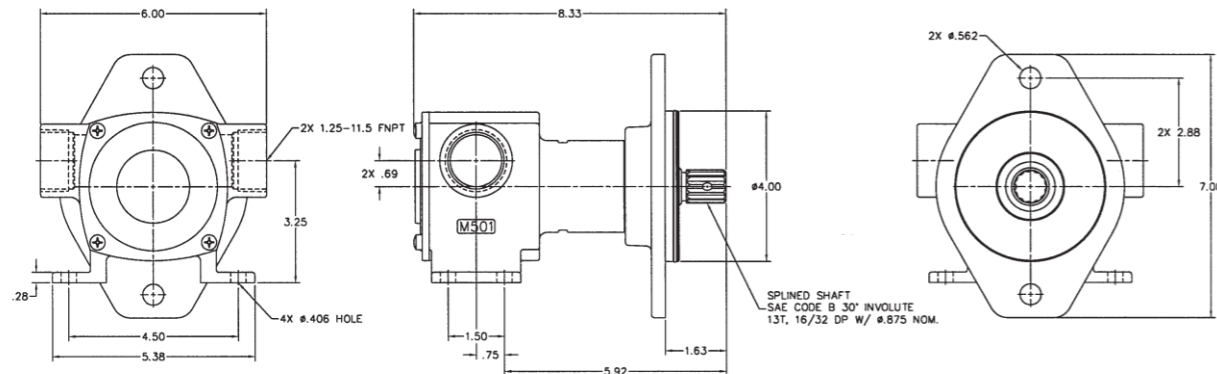

DIMENSIONS
501-07

501M PEDESTAL

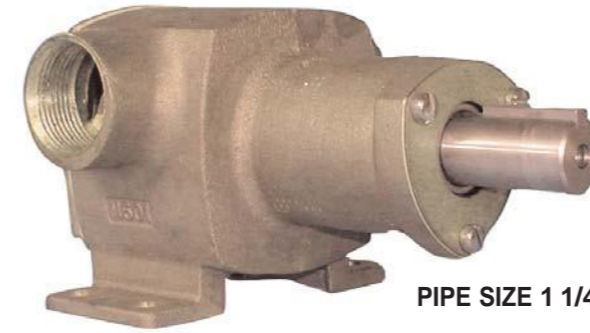

501E CLUTCH DRIVEN



501-07 SAE B FLANGE MOUNT



FEATURES

- Bronze Construction - Corrosion Resistance
- Machined-in cam for reduced impeller wear
- Teflon Barrier Seals Protecting Ball Bearings
- Mechanical Carbon Ring, Ceramic Face Main Pump Seal
- Two Sealed Ball Bearings Spaced for Maximum Load Ability
- Large Vent & Drain Openings Separate Seal & Bearing Areas
- Shaft Slinger for Additional Bearing Protection
- Neoprene (05) or Buna (06) impellers
- Stainless Steel Shaft
- O-Ring Seal Between Body and Cover
- Impeller easily replaced
- Option: Flanged Engine mount SAE 'B' available

ROTATION

Direction of shaft rotation determines inlet and outlet ports (see line drawing)

MOUNTING

Pump will operate satisfactorily when mounted in any position. **DO NOT RUN DRY.** Rubber impellers generate high rubbing friction unless lubricated by liquid pumped. Lack of liquid will cause impeller to burn up.

DRIVE

Either direct drive with flexible coupling or pulley drive can be used. Make sure both flexible coupling halves are properly aligned. When using pulley, do not overtighten belt.

LIQUIDS AND TEMPERATURE

Liquids compatible with neoprene (05) can be pumped including fresh and salt water solutions and mild chemicals. Do not pump severe solvents or acids. Buna (06) impellers can handle oil contaminated water. When possible, flush pump with fresh water after each usage.

Extremes of cold and heat will affect impeller life. Limits of 40° to 140° F should be observed. Do not allow liquid in pump to freeze. Drain pump by loosening cover screws. Use methyl alcohol based anti-freeze compounds such as Zerex®, Shell Zone®, Pyro Permanent®, Permagard®, Dowgard®.

SUCTION LIFT

Suction lift of 15 feet is possible when impeller is wet. Suction lines must be air tight in order for pump to self prime. A foot valve at beginning of suction line is recommended.

PERFORMANCE

WATER AT 60°F

BUNA (NITRILE)

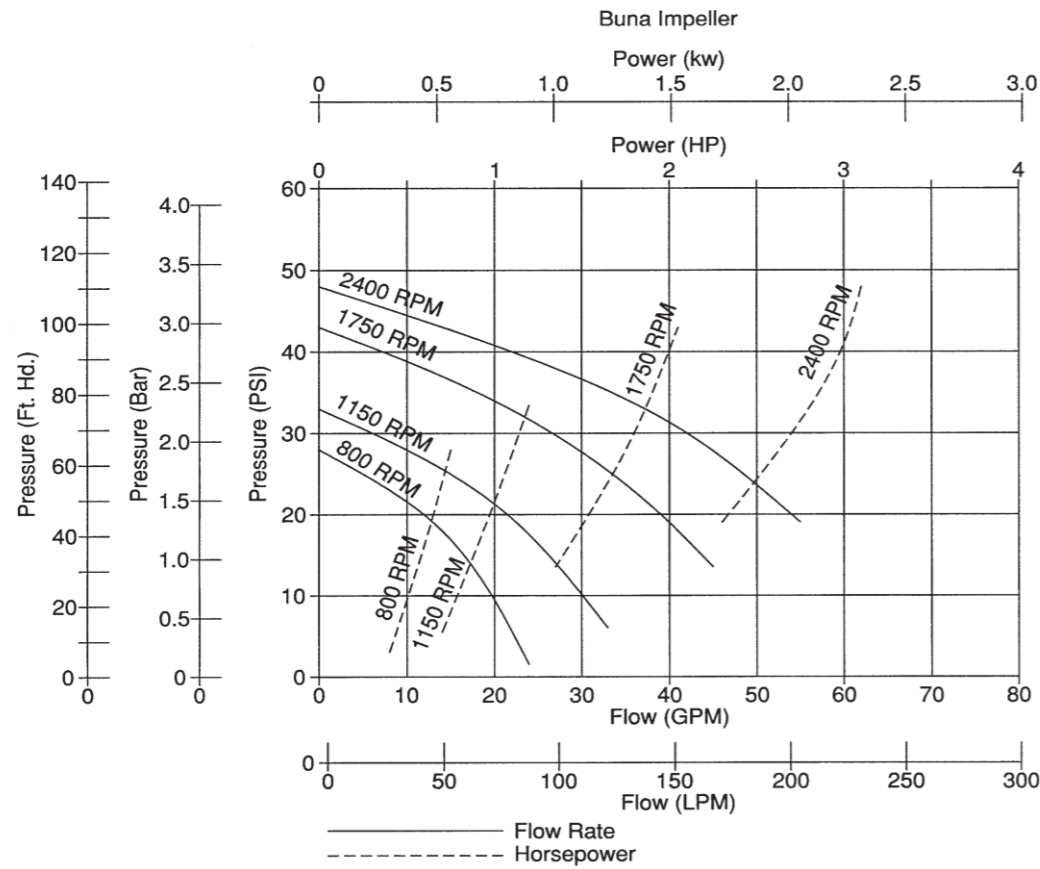

NEOPRENE

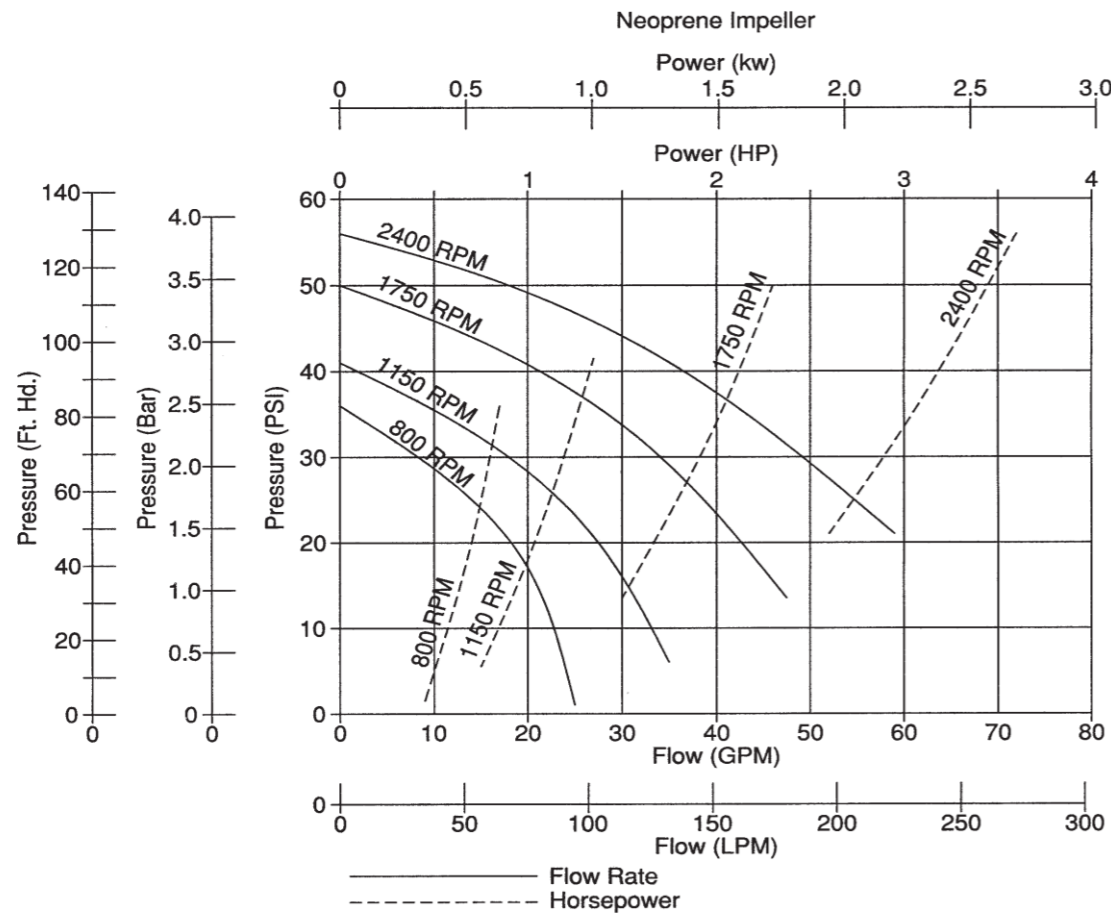

EXPLODED VIEW AND PARTS LIST

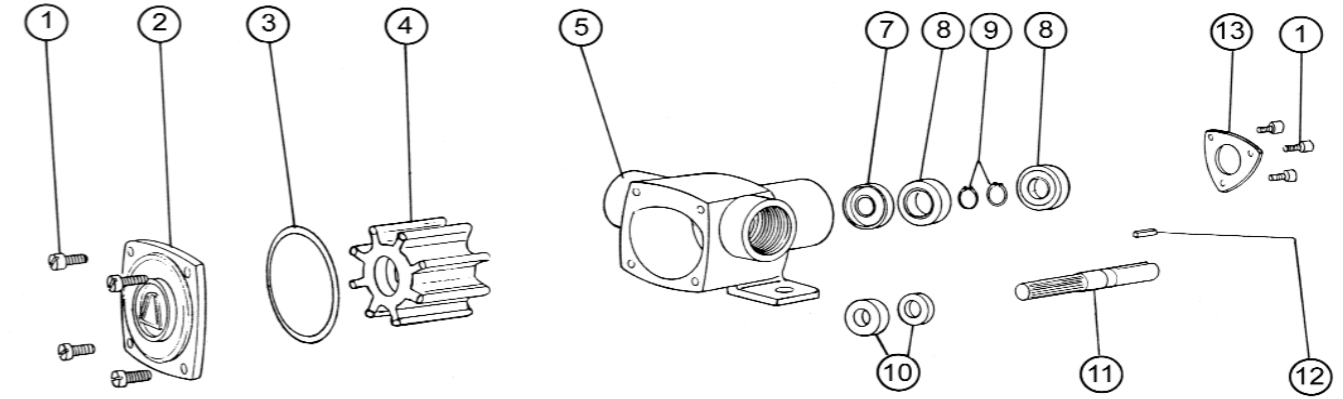

Pump No	Configuration	1	2	3*	4*	5	6	7	8	9	10*	11	12	13	14	15	16	Repair Kit *
		Screw 7 or 4 Req'd	Cover 1 Req'd	O-ring 1 Req'd	Impeller 1 Req'd	Body 1 Req'd	Set Screw 1 or 4 Req'd	Lip Seal 1 Req'd	Ball Bearing 2 Req'd	Ret. Ring 2 Req'd	Seal Assy 1 Req'd	Shaft 1 Req'd	Key 1 Req'd	End Plate or Flange 1 Req'd	Lip Seal 1 Req'd	Flange O-ring 1 Req'd	Flange Gasket 1 Req'd	
501M-05	Pedestal / Neoprene	5504	6717	8232	7054	9932	6436	6710	6332	6559	32953	9930	6342	6713	-----	-----	-----	10706
501M-06	Pedestal / Buna	5504	6717	8232	7593	9932	6436	6710	6332	6559	32953	9930	6342	6713	-----	-----	-----	11672
501-07	SAE B / Neoprene	5504	6717	8232	7054	9932-1	6436	6710	6332	6559	32953	9930-1	-----	2396	7262	2395-044	2397	10706

* Repair Kit includes these items

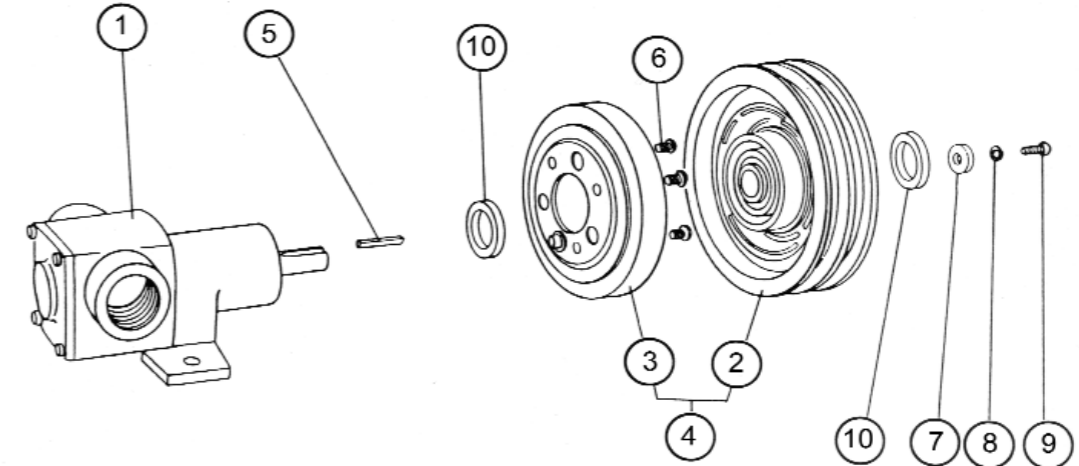

Pump No.	1**	2	3	4*	5	6	7	8	9	10	Clutch Kit #
	Pump	Clutch Body	Coil	Clutch Assy	Key	Screw	Washer	Lock Washer	Screw	Spacer	
501-05E12	501M-05	7227	7224	32238	6711	6437	6663	5016	7735	6715	10717
501-05E24	501M-05	7227	9902	33066	6711	6437	6663	5016	7735	6715	10853
501-05E32	501M-05	7227	7225	32239	6711	6437	6663	5016	7735	6715	10856
501-06E12	501M-06	7227	7224	32238	6711	6437	6663	5016	7735	6715	10717
501-06E32	501M-06	7227	7225	32239	6711	6437	6663	5016	7735	6715	10856

* Item 4 Clutch Assy. Is items 2 & 3 combined.

** Item 1 is pump listed above with (3) 5504 screws removed.

E 12 models are 12 Volt D.C., E 32 models are for 32 Volt D.C.

Clutch Kits contain items 2, 3, 5, 6, 7, 8, 9 & 10.

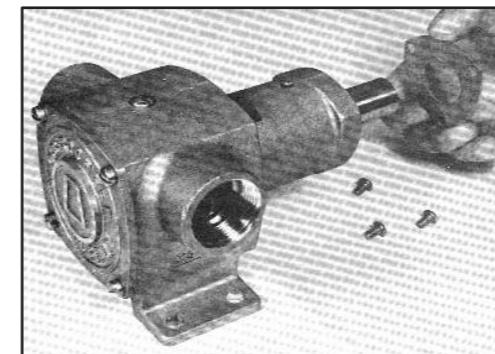

INSTALLING ELECTRIC CLUTCH PARTS

1. Remove bearing end plate as shown in photograph.
2. Slide spacer ring item 10 onto pump shaft against bearing.
3. Attach electric coil portion of clutch item 3 to pump body using three screws item 6 previously removed.
4. Insert shaft key item 5 into shaft keyslot.
5. Slide pulley portion of electric clutch item 2 onto pump shaft engaging the shaft key.
6. Slide spacer ring item 10 onto pump shaft.
7. Install washer item 7.
8. Install lockwasher item 8.
9. Install screw item 9.