

ANSI 1796 Series

CHEMICAL PROCESS SELF PRIMING PUMPS

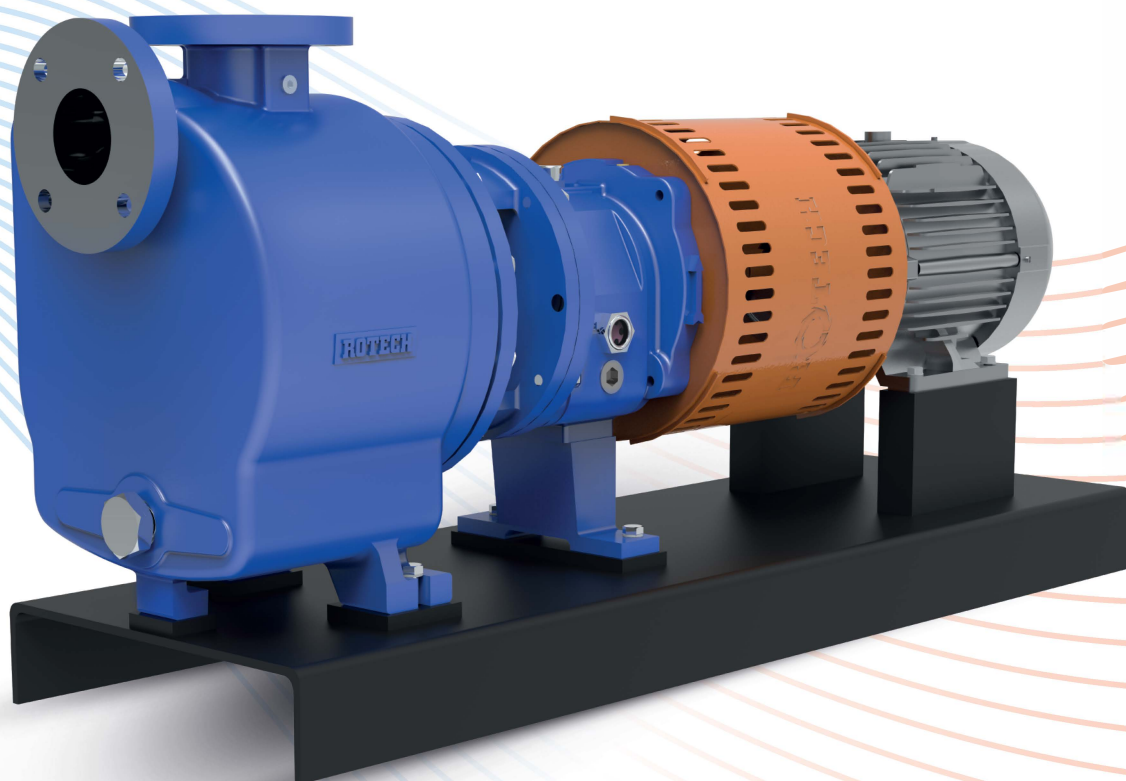

QUALITY | COMMITMENT | ADAPTABILITY



HIGH ON **PERFORMANCE**
GREAT ON **RELIABILITY**

PUMP DESIGN FEATURES / ADVANTAGES

Rotech 1796 Series ANSI Self priming pumps are designed to provide self priming application in chemical process, oil & gas, petro-chemical, water, and wastewater industries. Rotech ANSI self priming pump offers interchangeability of parts with 1196 series of Pumps.

Definitive Self - Priming Operation

- Prior to any centrifugal pump operation, it's first task is to be primed; so that gases or air extracted from the impeller eye area and suction, and filled with liquid. There is no problem when the pump is submerged or liquid supply is above the pump. But, when suction pressure is negative, air must be expelled to achieve pump priming.
- Rotech 1796 series is designed to assure that adequate amount of liquid for reprime always keep inside the priming chamber that makes it completely operational, compact and integral self-priming pump.

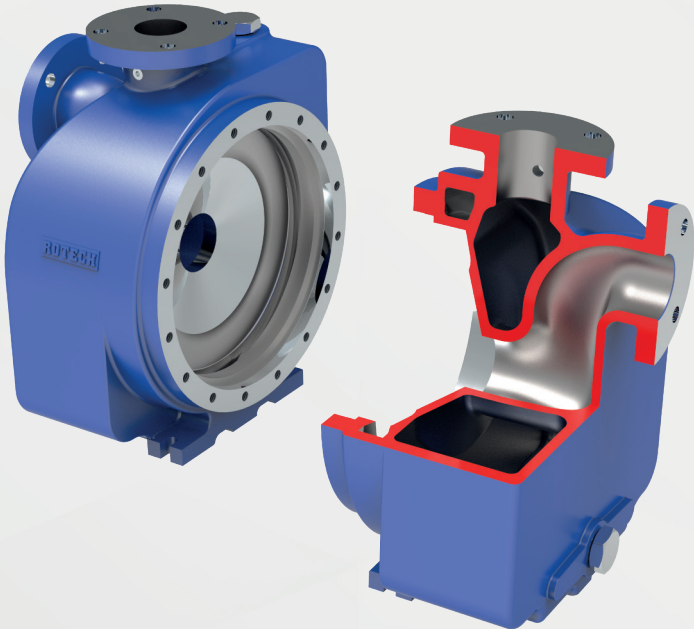

Priming achieved inside Casing

- In Dual volute designed casing an initial amount of liquid is use for suction priming. During this process, the lower volute work as suction while upper volute discharges liquid and driving air into separation chamber.
- While liquid recirculates into lower volute, air is separated and removed from pump discharge. Once air is completely removed from suction and liquid fill impeller eye, pump is fully primed and works as conventional centrifugal pump with both volute work as discharge.

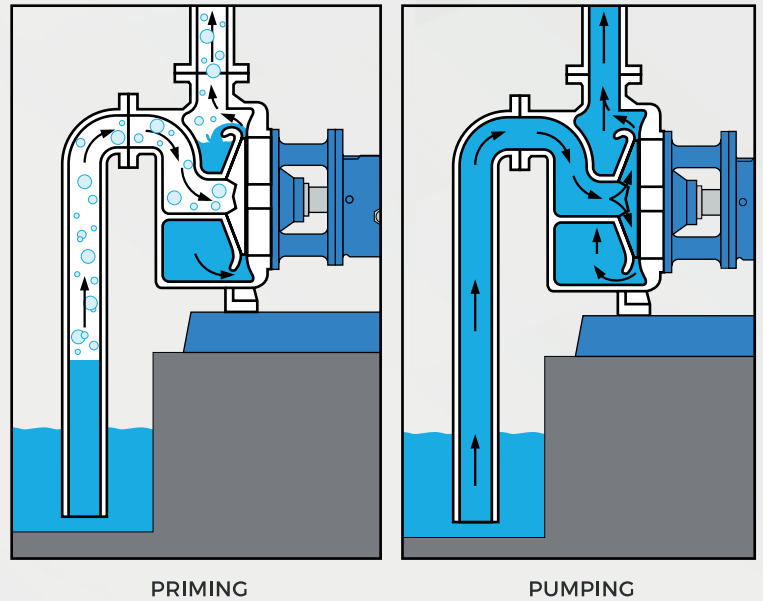

Performance Features

- One-piece casing with integral priming and air separation
- Positive retention of pumpage under siphon conditions
- Rapid priming time
- Self-purge of vapors

Maintenance Advantage

- Back pull-out design
- External impeller adjustment
- Parts interchangeable with Rotech model 1196
- Easy retrofit

ROTECH ANSI / ASME B73.1 PROCESS PUMP

Design Features



Material Options

- Ductile iron · Carbon steel · Stainless Steel · Duplex SS · Alloy 20
- Hastelloy B & C · Nickel Alloys · Titanium and Any Other Special Alloys

Power Frame

- Bearing Frame: Ductile Iron Standard
Optional: Carbon Steel, 316SS.
- Internal surface cleaned, rust preventive applied, and enamel coated assuring internal casting cleanliness.

Shaft and Shaft Kit Assembly

- AISI 4140 Steel Shaft as a standard,
Optional: 316SS Sleeved, 316SS Solid Shaft, 2205, 2507, Alloy 20 or any other special alloys against request.

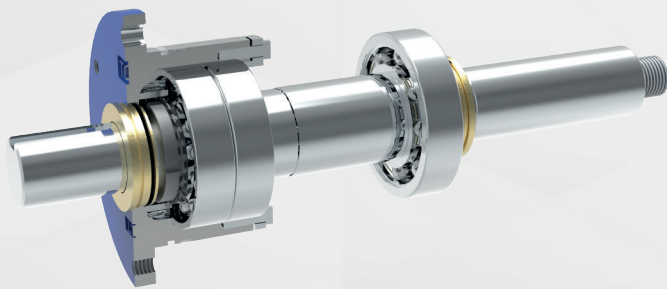

Base Frame Options

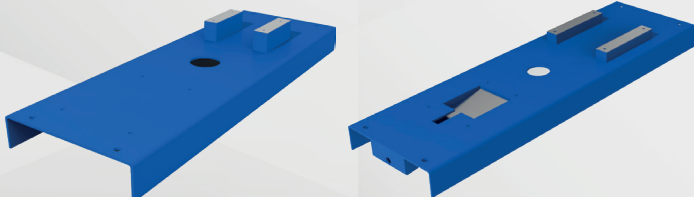

1796 Base Frame
Sheet Metal

1796 Drip Pan
Base Frame

Stuffing Box Covers / Sealing Options

- Standard Bore: Designed for packing & mechanical seal.
- Large Bore: Improved cooling & lubrication.
- Taper Bore: Lower seal face temperature, self-venting and draining, solid & vapours circulated away from seal face.

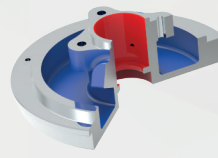

Standard Bore

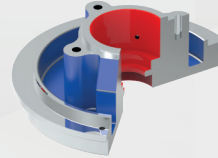

Large Bore

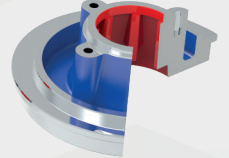

Taper Bore



Component Seal

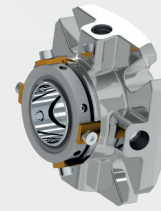

Single
Cartridge Seal

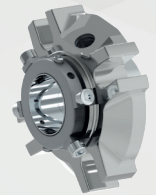

Dual
Cartridge Seal

High Temperature Application

- Finned Cooler: Directly cools oil for lower bearing temperature. Requires minimum cooling water. Corrosion resistant construction. Recommended for temperature over 350°F (177°C)
- Jacketed Stuffing Box: Keep proper temperature control of sealing environment. Perfect for polymerizing liquids.
- Jacketed Casing: Ideal for heating or cooling applications.

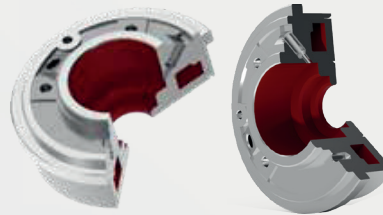

Jacketed SBC



Finned Cooler

Dynamic Sealing Option

- Sealing problem eliminated, Maintenance cost minimized, Utility costs reduced. No external flushing required.

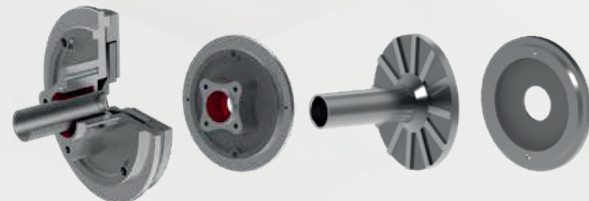

ROTECH ANSI/ASME B73.1 PROCESS PUMP

Design Features

Sealing Options & Stuffing box cover

- Various component & ANSI cartridge seal configurations
- Various API Sealing Flush Plans
- Leak protection with maximum heat dissipation, extended seal life and pump reliability

Casing

- Full line of corrosive resistant materials
- Centerline mounted discharge flange
- Precision serrated flange face finish for optimum gasket retention and sealing
- Flange Options: Class 150# (Standard) and Class 300# (Optional)
- Increased casing thickness for extended casing life.
- Back Pull-out design for easy maintenance

Gasket

- Non-Asbestos Aramid Fibre
- PTFE, Glass filled Teflon
- Positive liquid sealing

Impeller

- Semi-open Impeller design for increasing abrasion, corrosion and solid wear resistance
- Solid handling capacity with ease in pumping fibrous material
- Back pump-out vanes reduces pressure on shaft seal
- Adjustment of clearance is easy when wear & tear takes place

Casing Drain

- Casing drain port as standard
- Drain piping as optional

Foot Mounted Casing

- Maximum casing stability and support for back pull out maintenance feature
- Reduced vibration

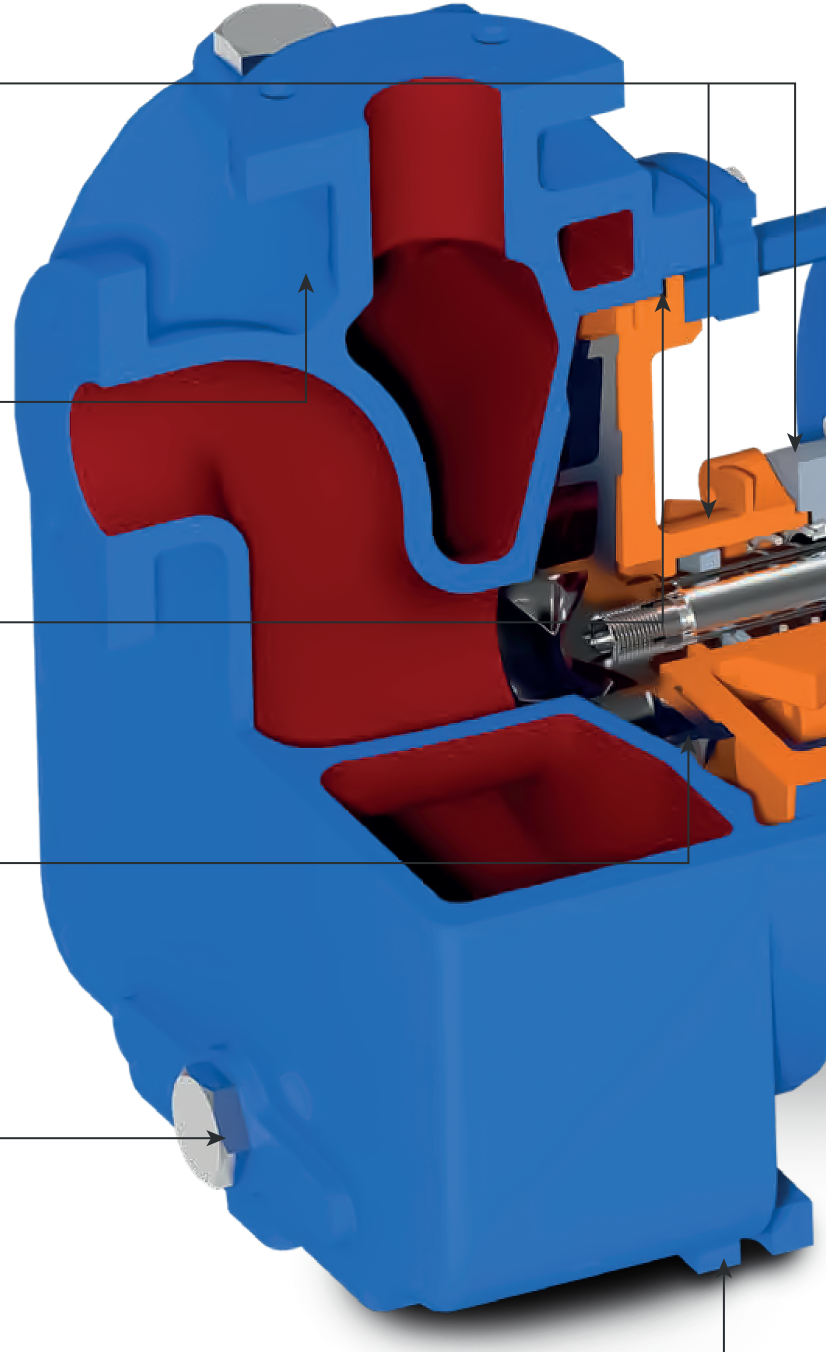

DELIVERY

Pumps / parts are strategically inventoried at various locations in North America, Asia for rush delivery in various material options.

PUMP SELECTOR PROGRAM

Helps to select & size the pumps for various applications. Please contact us for more details.

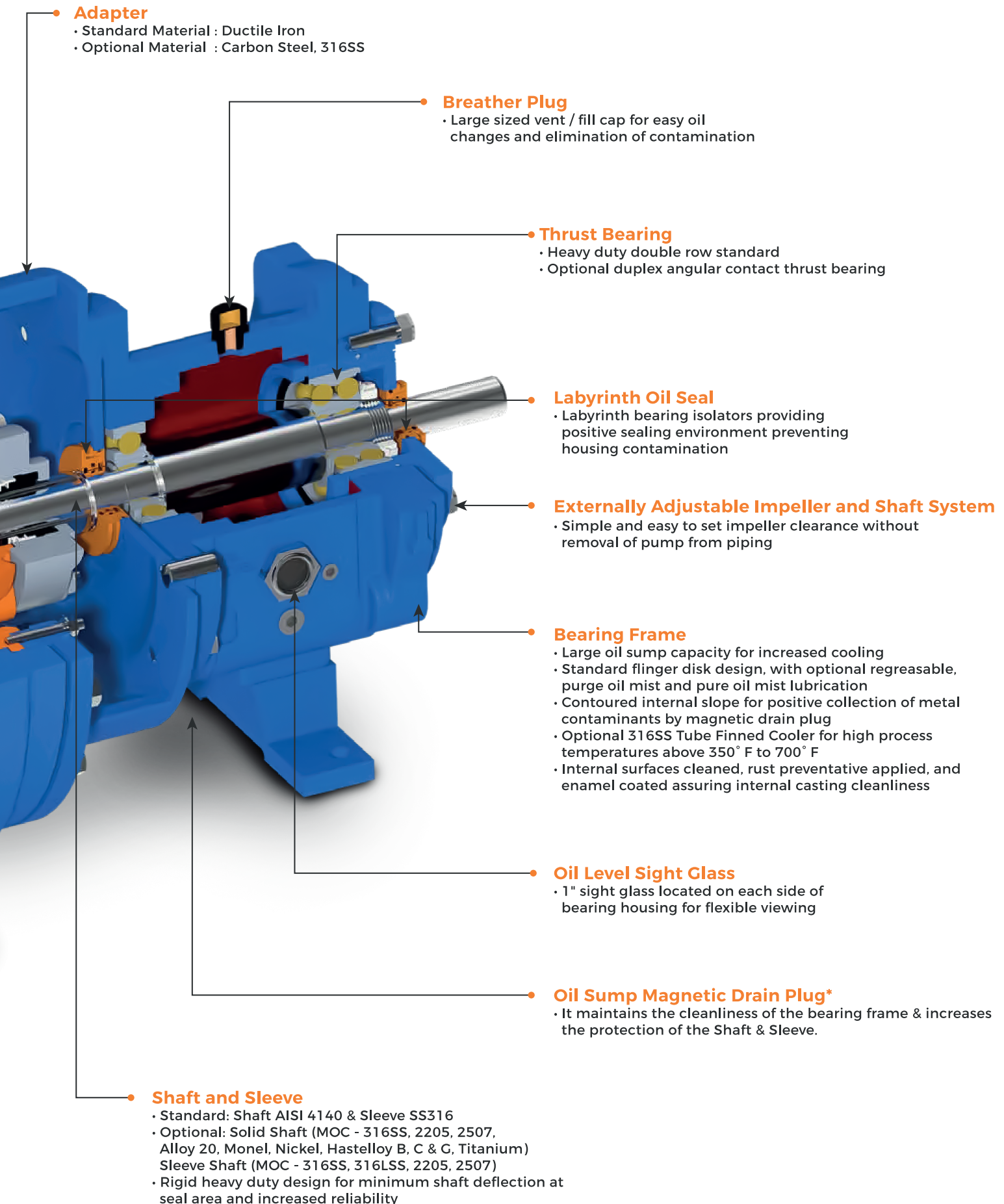

• **Adapter**

- Standard Material : Ductile Iron
- Optional Material : Carbon Steel, 316SS

• **Breather Plug**

- Large sized vent / fill cap for easy oil changes and elimination of contamination

• **Thrust Bearing**

- Heavy duty double row standard
- Optional duplex angular contact thrust bearing

• **Labyrinth Oil Seal**

- Labyrinth bearing isolators providing positive sealing environment preventing housing contamination

• **Externally Adjustable Impeller and Shaft System**

- Simple and easy to set impeller clearance without removal of pump from piping

• **Bearing Frame**

- Large oil sump capacity for increased cooling
- Standard flinger disk design, with optional regreasable, purge oil mist and pure oil mist lubrication
- Contoured internal slope for positive collection of metal contaminants by magnetic drain plug
- Optional 316SS Tube Finned Cooler for high process temperatures above 350° F to 700° F
- Internal surfaces cleaned, rust preventative applied, and enamel coated assuring internal casting cleanliness

• **Oil Level Sight Glass**

- 1" sight glass located on each side of bearing housing for flexible viewing

• **Oil Sump Magnetic Drain Plug***

- It maintains the cleanliness of the bearing frame & increases the protection of the Shaft & Sleeve.

• **Shaft and Sleeve**

- Standard: Shaft AISI 4140 & Sleeve SS316
- Optional: Solid Shaft (MOC - 316SS, 2205, 2507, Alloy 20, Monel, Nickel, Hastelloy B, C & G, Titanium)
- Sleeve Shaft (MOC - 316SS, 316LSS, 2205, 2507)
- Rigid heavy duty design for minimum shaft deflection at seal area and increased reliability

HYDRAULIC PERFORMANCE COVERAGE

4 Pole Motor

Capacity up to 1350 GPM (307 m³/h) | Head up to 165 feet (50 m) | Temperature to 500°F (260°C)
Pressure up to 375 PSIG (2586 kPa) | Effective static lift to 20 feet (6 m)

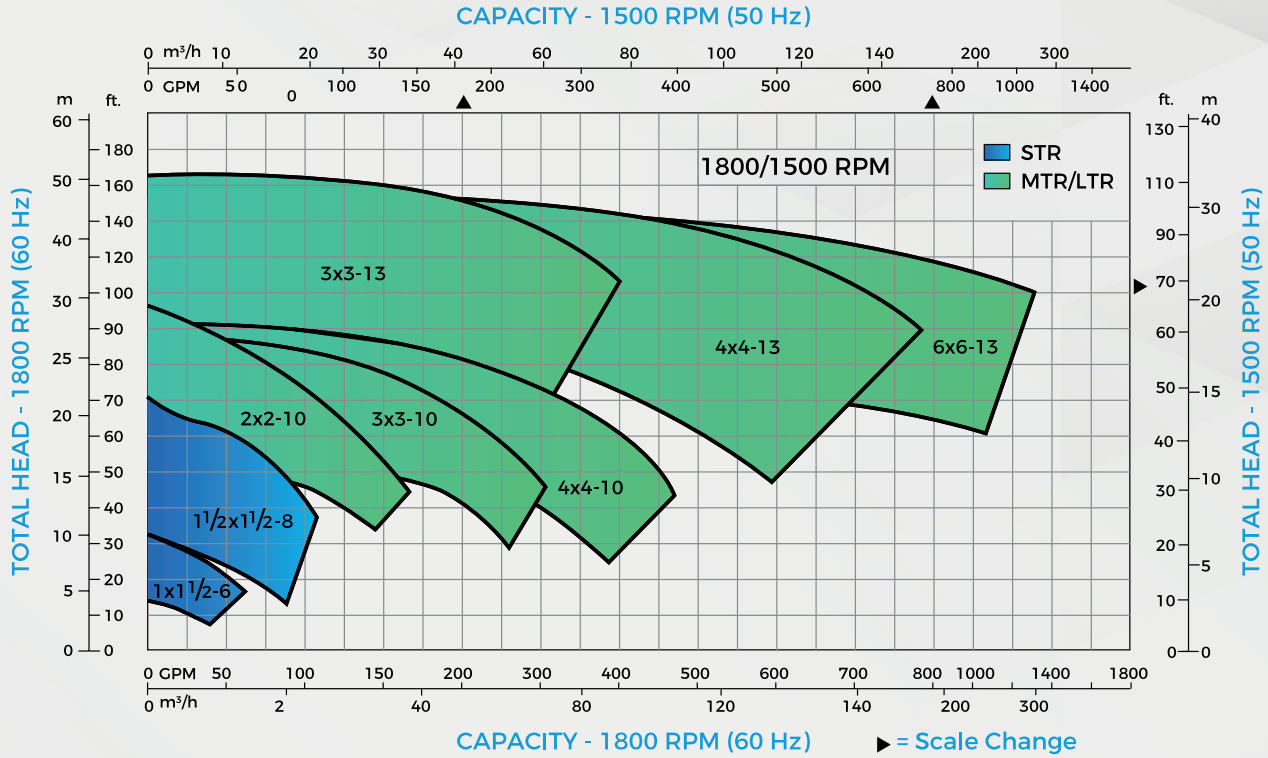

2 Pole Motor

Capacity up to 600 GPM (136 m³/h) | Head up to 430 feet (131 m) | Temperature to 500°F (260°C)
Pressure up to 375 PSIG (2586 kPa) | Effective static lift to 20 feet (6 m)

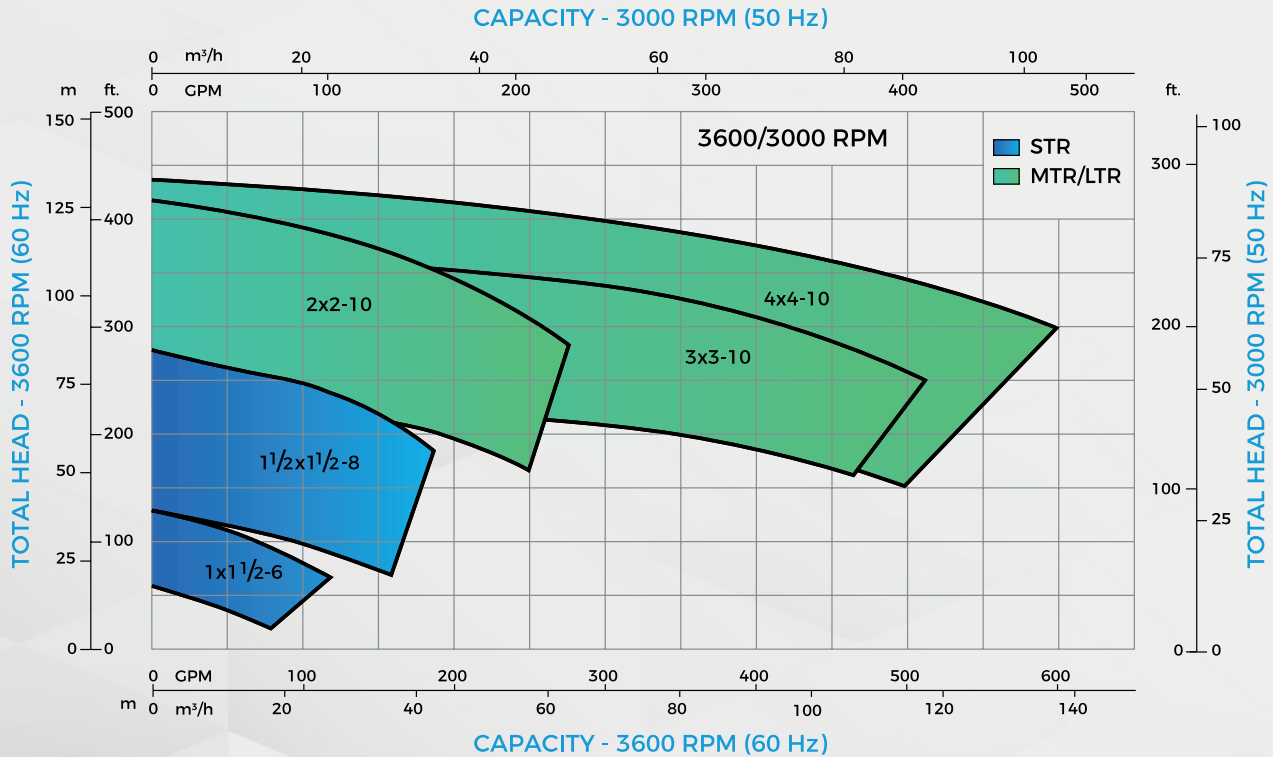

DIMENSIONAL DATA

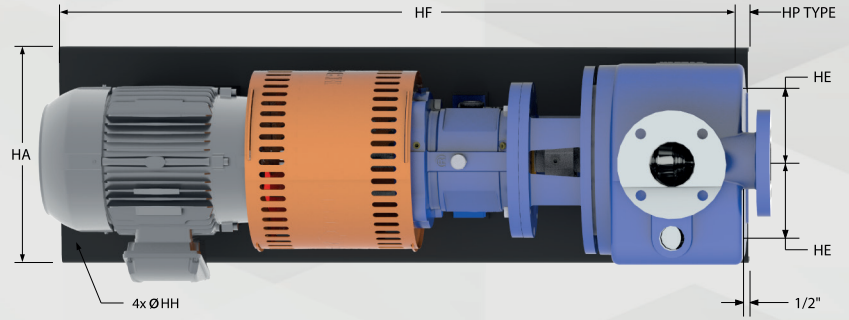
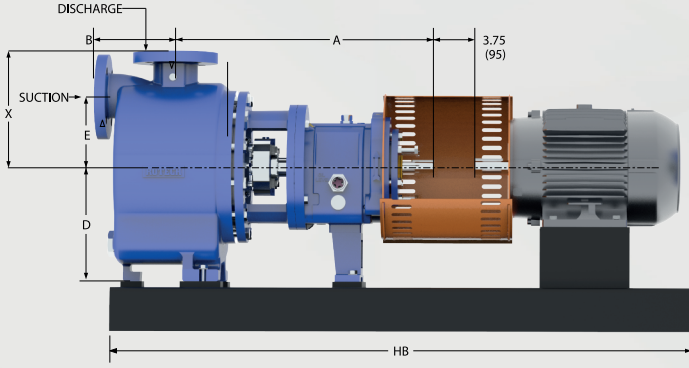

PUMP DIMENSIONS AND WEIGHTS

PUMP FRAME	PUMP SIZE	DISCHARGE SIZE	SUCTION SIZE	X	A	B	D	E	SP	RARE PUMP WEIGHT LBS (KG)
STR	1x1.5-6	1	1.5	7.25(184)	15.5(394)	5(127)	7.5(191)	4(102)	3.75(95)	85(38)
	1.5x1.5-8	1.5		7.875(200)						170(77)
MTR/LTR	2x2-10	2	2	10(254)	21.75(552)	6.5(165)	10(254)	6(152)		270(123)
	3x3-10	3	3	22.625(575)	6.75(171)	315(143)				
	4x4-10	4	4	23.375(594)	9.18(233)	370(168)				
	3x3-13	3	3	11.5(292)	22.625(575)	6.75(171)	400(182)			
	4x4-13	4	4	23.375(594)	9.18(233)	470(214)				
	6x6-13	6	6	15(381)	23.375(594)	10(254)	12(304.8)	8(203)	690(314)	

PARTS LIST AND MATERIALS OF CONSTRUCTION

PART#	PART NAME	Carbon Steel	Carbon Steel w/ 316SS Impeller	316SS	316L SS	Duplex SS	Super Duplex SS	Alloy 20 (Carpenter 20)	Monel	Nickel	Hastelloy B & C	Titanium	
100	Casing	CS	CS	316SS	316L SS	CD4MCUN	SS Gr5A	Alloy 20	Monel	Nickel	Hastelloy B & C	Titanium	
101	Impeller	CS	316SS	316SS	316L SS	CD4MCUN	SS Gr5A	Alloy 20	Monel	Nickel	Hastelloy B & C	Titanium	
106	Packing, Stuffing Box (Optional)	Teflon - Impregnated Fibers										Titanium	
108	Adapter, Frame*	DI (Optional : Carbon Steel)					DI (Optional : Carbon Steel/316SS)					Titanium	
122	Shaft - Less Sleeve (Optional)	AISI4140	316SS (Optional 316L SS, Alloy 20 & A2205)			2205	2507	Alloy 20	Monel	Nickel	Hastelloy B & C	Titanium	
122	Shaft with Sleeve				AISI4140	316SS					Titanium		
126	Shaft Sleeve	316SS				316L SS	CD4MCUN	Gr5A	Alloy 20	Monel	Nickel	Hastelloy B & C	Titanium
134	Thrust Bearing Housing	DI (Optional : Carbon Steel)					DI (Optional : Carbon Steel/316SS)					Titanium	
184	Cover, Stuffing Box (Packed Box)	CS	CS	316SS	316L SS	CD4MCUN	SS Gr5A	Alloy 20	Monel	Nickel	Hastelloy B & C	Titanium	
184	Seal Chamber (Mechanical Seal)	CS	CS	316SS	316L SS	CD4MCUN	SS Gr5A	Alloy 20	Monel	Nickel	Hastelloy B & C	Titanium	
228	Frame, Bearing	DI (Optional : Carbon Steel)					DI (Optional : Carbon Steel/316SS)					Titanium	
250	Gland - Seal/Packing	CS	CS	316SS	316L SS	CD4MCUN	SS Gr5A	Alloy 20	Monel	Nickel	Hastelloy B & C	Titanium	
319	Sight Glass - Oil											Titanium	
332A	Labyrinth Seal (IB & OB)											Titanium	
358	Plug, Casing Drain (Optiona)	MS	MS	316SS	316L SS	Duplex A2205	A2507	Alloy 20	Monel	Nickel	Hastelloy B & C	Titanium	
637	Breather Plug	Carbon Steel										Titanium	

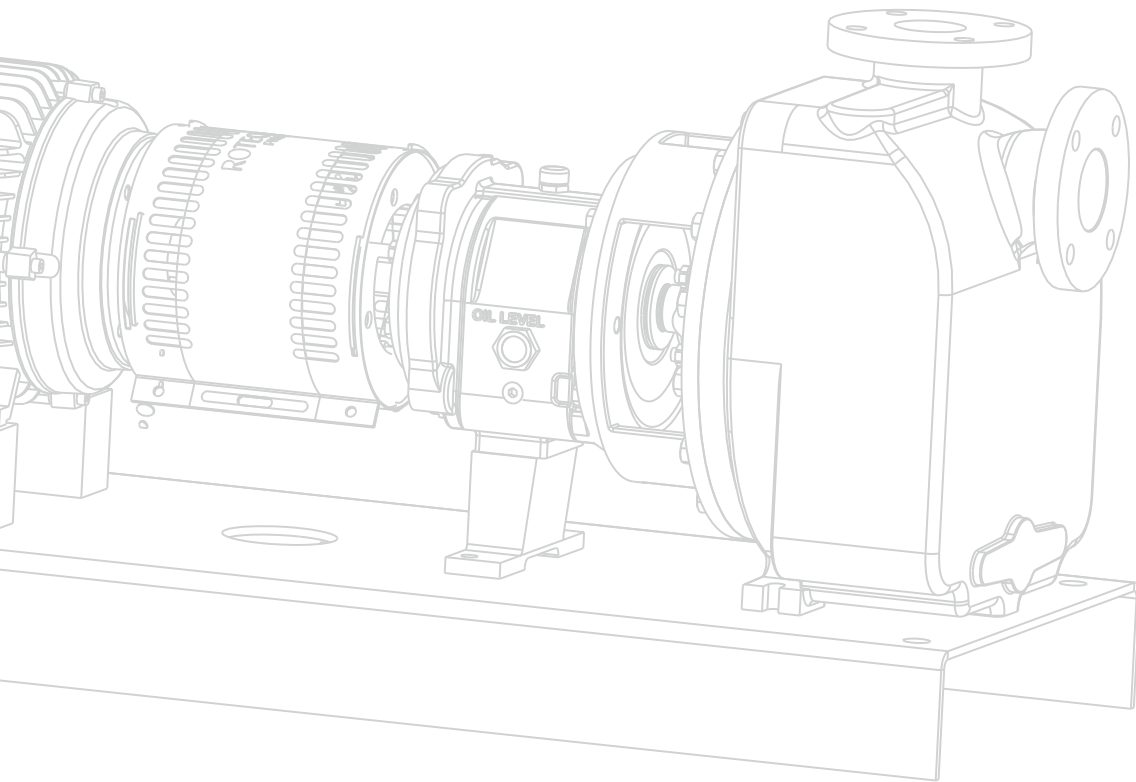

QUALITY | COMMITMENT | ADAPTABILITY

CANADA

Headquarters

1180 Britannia Road East,
Mississauga, Ontario, L4W 1C8

☎ 1 - 866 - 217 - 7867

✉ sales@rotechpumps.com



USA

Headquarters

4555 Brittmoore Road,
Houston, Texas, 77041

☎ 1 - 866 - 217 - 7867

✉ sales@rotechpumps.com

www.rotechpumps.com