

D
C
B

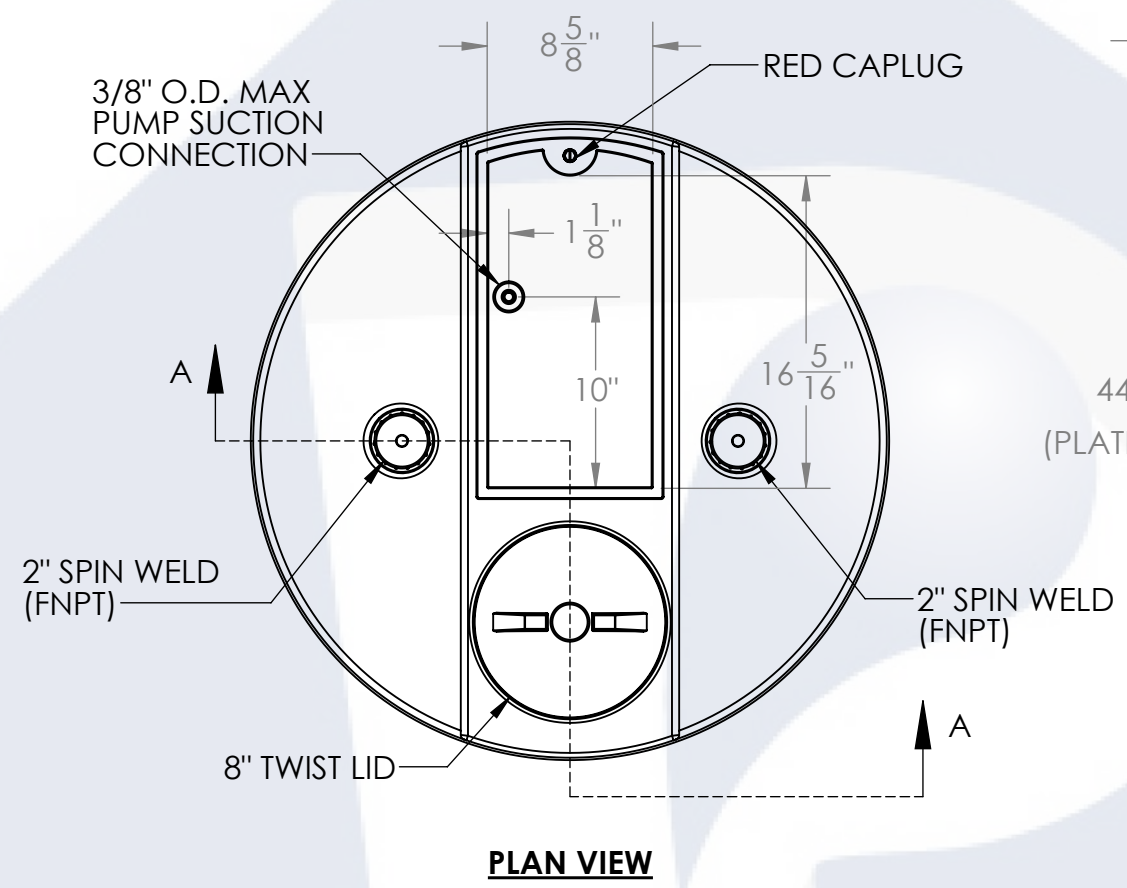

**ISOMETRIC VIEW
(ASSEMBLED)**



PLAN VIEW

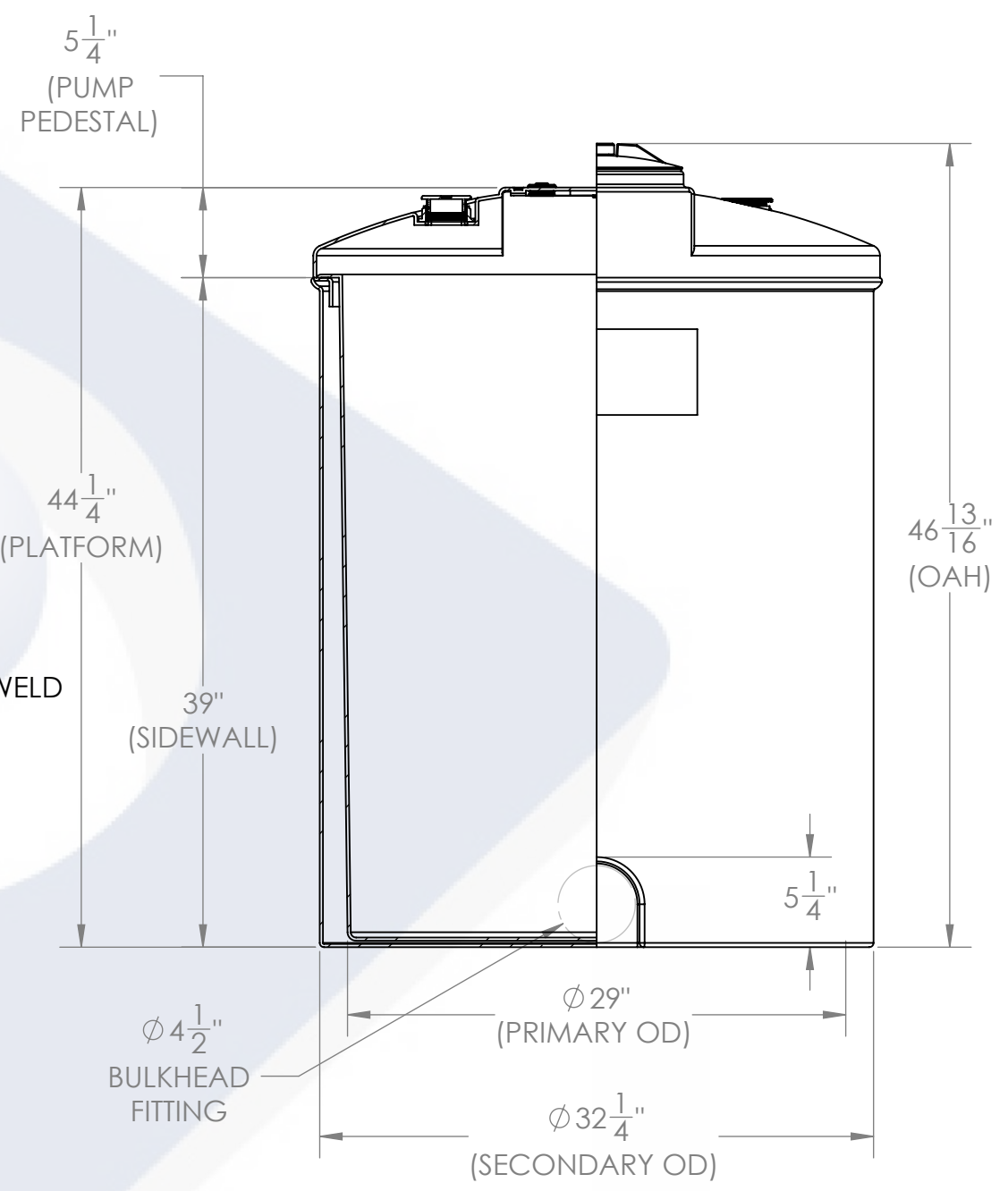

SECTION A-A

ALTERNATE CONFIGURATION TO MEET
NSF/ANSI STANDARD 61 AVAILABLE

120 GALLON GEMINI TANK, Ø33" x 47"	PART NUMBER	
	BLUE	NATURAL
POLYETHYLENE LDPE (SD 1.5)	01-14870	01-1072
POLYETHYLENE LDPE (HD 1.9)	01-29777	01-29768
CROSSLINK XLPE (SD 1.5)	CALL FOR INFO	01-30130
CROSSLINK XLPE (HD 1.9)	CALL FOR INFO	01-30141
ALTERNATIVE MATERIALS, COLOR, AND ACCESSORIES ARE AVAILABLE. CALL FOR ADDITIONAL INFO.		

PROPRIETARY AND CONFIDENTIAL
THE INFORMATION CONTAINED IN THIS DRAWING IS THE SOLE PROPERTY OF PEABODY ENGINEERING. ANY REPRODUCTION IN PART OR AS A WHOLE WITHOUT THE WRITTEN PERMISSION OF PEABODY ENGINEERING IS PROHIBITED.

UNLESS OTHERWISE SPECIFIED:		NAME	DATE	
DIMENSIONS ARE IN INCHES TOLERANCES: ±1/4" ANGULAR: ±.5° ONE PLACE DECIMAL: ±.25 TWO PLACE DECIMAL: ±.125 THREE PLACE DECIMAL: ±.063		AAE	8/19/19	
TANK MATERIAL:				PROJECT: GEMINI DUAL CONTAINMENT TANKS
INNER TANK S/N:				CUSTOMER: PEABODY STANDARD
OUTER TANK S/N:				SITE/LOCATION: -
CUSTOMER PO#				SALES ORDER:
DO NOT SCALE DRAWING				SIZE: B DESC.: 120 GALLON GEMINI TANK, Ø33" x 47" REV.: E
				SCALE: 1:10 SHEET 1 OF 1