

ANSI LOW FLOW HIGH HEAD
1196LF SERIES

CHEMICAL PROCESS PUMPS

ASME B73.1 STANDARD



QUALITY | COMMITMENT | ADAPTABILITY

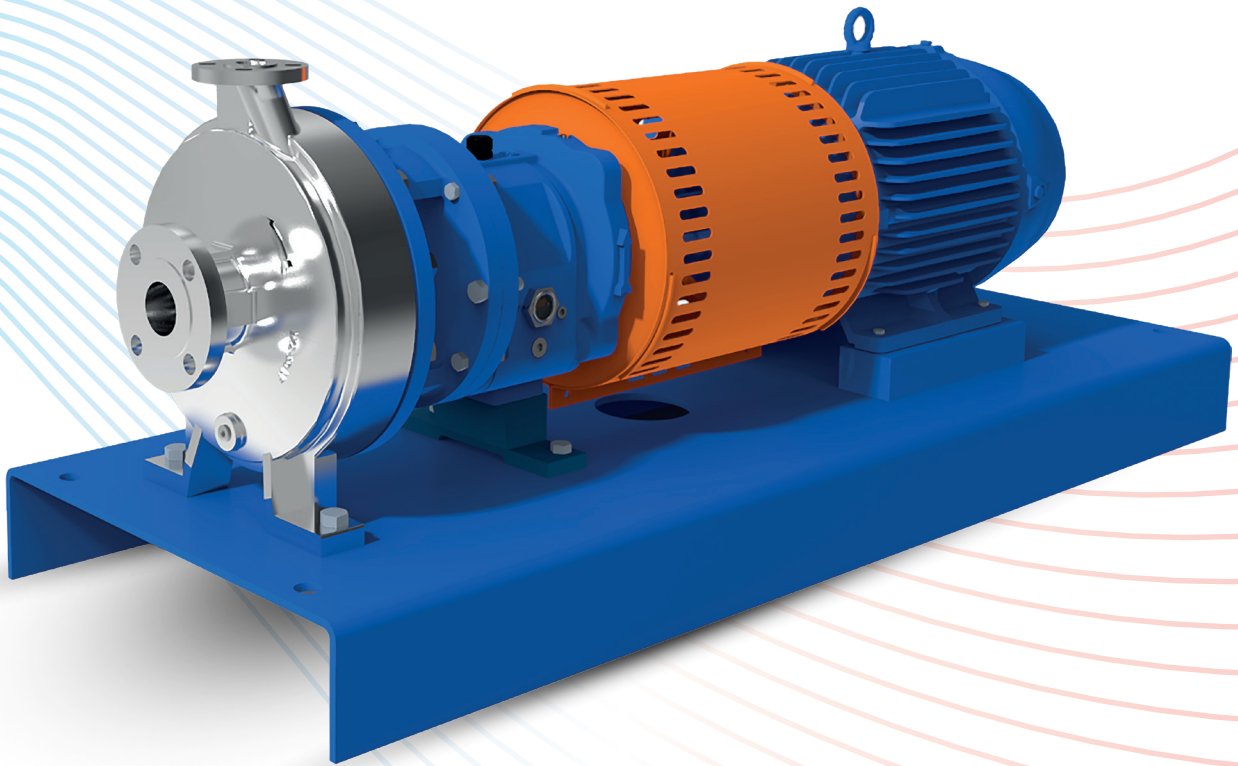

HIGH ON **PERFORMANCE**
GREAT ON **RELIABILITY**

THE 1196LF PROCESS PUMP IS DESIGNED TO OFFER LOW FLOW & HIGH PRESSURE APPLICATION IN INDUSTRIAL PROCESS APPLICATIONS.

Design Features

- Rotech LF 1196 circular (concentric volute) casing and open radial vane impeller are designed to eliminate hydraulic and mechanical problems at throttled low flow.
- **Circular Volute Casing**
Reduces radial loads during low flow condition. Mechanical seal and bearings life is longer. Fully machined discharge and volute provide maximum efficiency and precision control of hydraulics at low flow.
- **Rotech LF Impeller**
Multiple open radial vanes reduce vibrations pulsations, and vane stress Full shroud for superior vane strength when operating at extreme low flows. Balance holes reduce axial thrust, maximize stuffing box/seal chamber pressure for longer seal and bearing life.

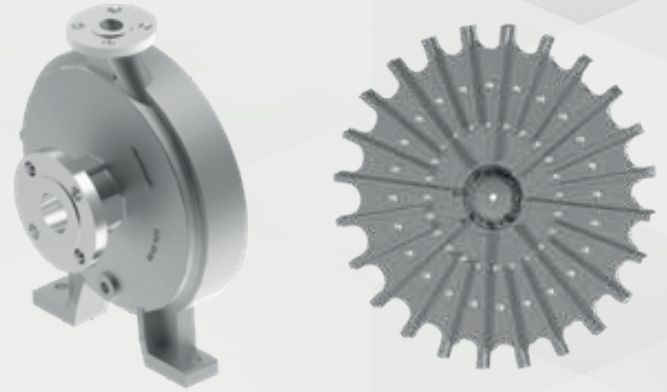

Disadvantages of Throttled Typical end Suction Pump

- Resultant higher radial loads
- Higher shaft deflection
- Failure of Bearing & Mechanical seal before their life cycle
- Unscheduled shut down.
- Higher service cost

To overcome all these disadvantages 1196LF Process Pump is designed to offer Low Flow with High pressure application in Process Industries.

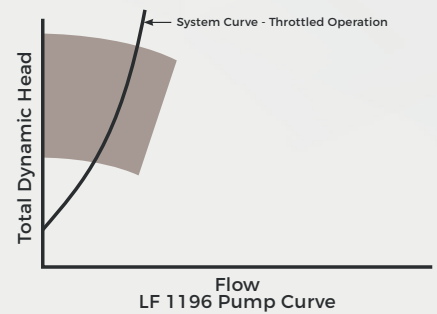
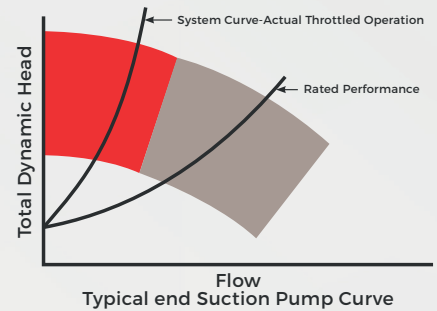

- Off Design Operation Range
- Recommended Operation Range

Reduced radial loads for optimum reliability.

- Radial loads are reduced by as much as 75% compared to end suction expanding volute pumps at low flows. Bearing, mechanical seal and overall pump life are optimized.

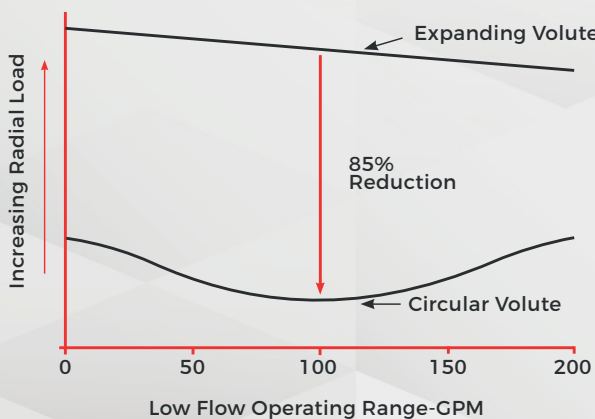

Expanding Volute Pump

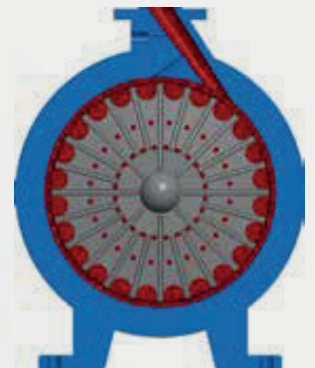

Rotech 1196LF Concentric Volute Pump

ROTECH ANSI / ASME B73.1 PROCESS PUMP

Stuffing Box Covers / Sealing Options

- Standard Bore: Designed for packing & mechanical seal.
- Large Bore: Improved cooling & lubrication.
- Taper Bore: Lower seal face temperature, self-venting and draining, solid & vapours circulated away from seal face.

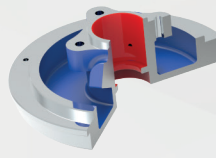

Standard Bore

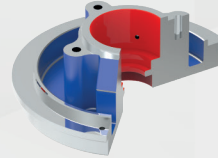

Large Bore

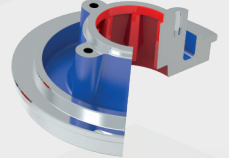

Taper Bore



Component Seal

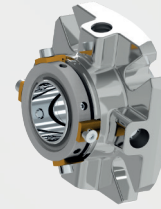

Single Cartridge Seal

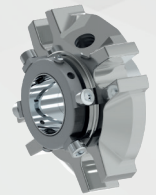

Dual Cartridge Seal

Material Options

- Ductile iron • Carbon steel • Stainless steel • Duplex SS • Alloy 20
- Hastelloy B & C • Nickel Alloys • Titanium and Any Other Special Alloys

Power Frame

- Bearing Frame: Ductile Iron Standard
Optional: Carbon Steel, 316SS.
- Internal surface cleaned, rust preventive applied, and enamel coated assuring internal casting cleanliness.

Shaft and Shaft Kit Assembly

- 4140 Steel Shaft as a standard,
Optional: 316SS Sleeved, 316SS Solid Shaft, 2205, 2507, Alloy 20 or any other special alloys against request.

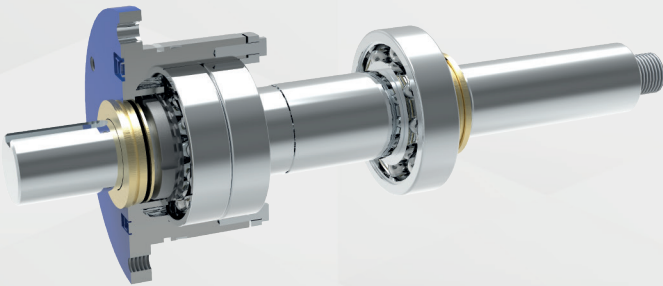

High Temperature Application

- Finned Cooler: Directly cools oil for lower bearing temperature. Requires minimum cooling water. Corrosion resistant construction. Recommended for temperature over 350°F (177°C)
- Jacketed Stuffing Box: Keep proper temperature control of sealing environment. Perfect for polymerizing liquids.
- Jacketed Casing: Ideal for heating or cooling applications.

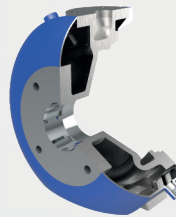

Jacketed Casing

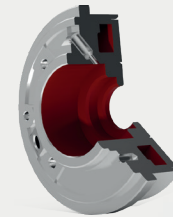

Jacketed SBC



Finned Cooler

Base Frame Options

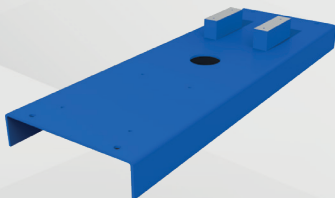

1196LF Base Frame Sheet Metal

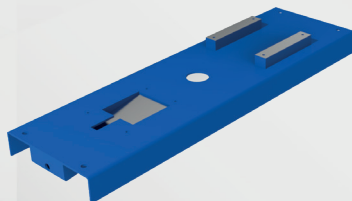

1196 Drip Pan Base Frame

Dynamic Sealing Option

Sealing problem eliminated, Maintenance cost minimized, Utility costs reduced, No requirement of external seal water.

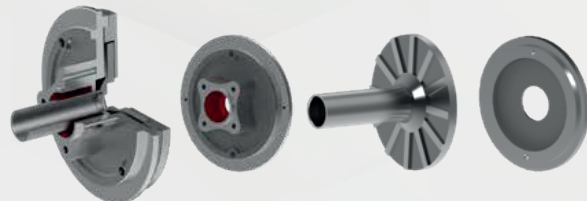

ROTECH ANSI / ASME B73.1 PROCESS PUMP

Sealing Options & Stuffing Box Cover

- Various component & ANSI cartridge seal configurations
- Various API Sealing Flush Plans
- Leak protection with maximum heat dissipation, extended seal life and pump reliability

Casing

- Full line of corrosive resistant materials
- Self venting, centerline mounted discharge flange
- Precision serrated flange face finish for optimum gasket retention and sealing
- Flange Options:-Class 150# RF (Standard) and Class 300# RF (Optional). Exception : 300# RF is standard in 1.5x3-13LF size.
- More casing thickness is provided as compared to ASME B73.1 specification for extended casing life.
- Back Pull out design for easy maintenance

Gasket

- Non-Asbestos Aramid Fibre
- PTFE, Glass filled Teflon
- Positive liquid sealing

Impeller

- Semi-open Impeller design for increasing abrasion, corrosion and solid wear resistance
- Solid handling capacity with ease in pumping fibrous material
- Back pump-out vanes reduces pressure on shaft seal
- Adjustment of clearance is easy when wear & tear takes place

Foot Mounted Casing

- Maximum casing stability and support for back pull out maintenance feature
- Reduced vibration

Casing Drain

- Casing drain port as standard
- Drain piping as optional

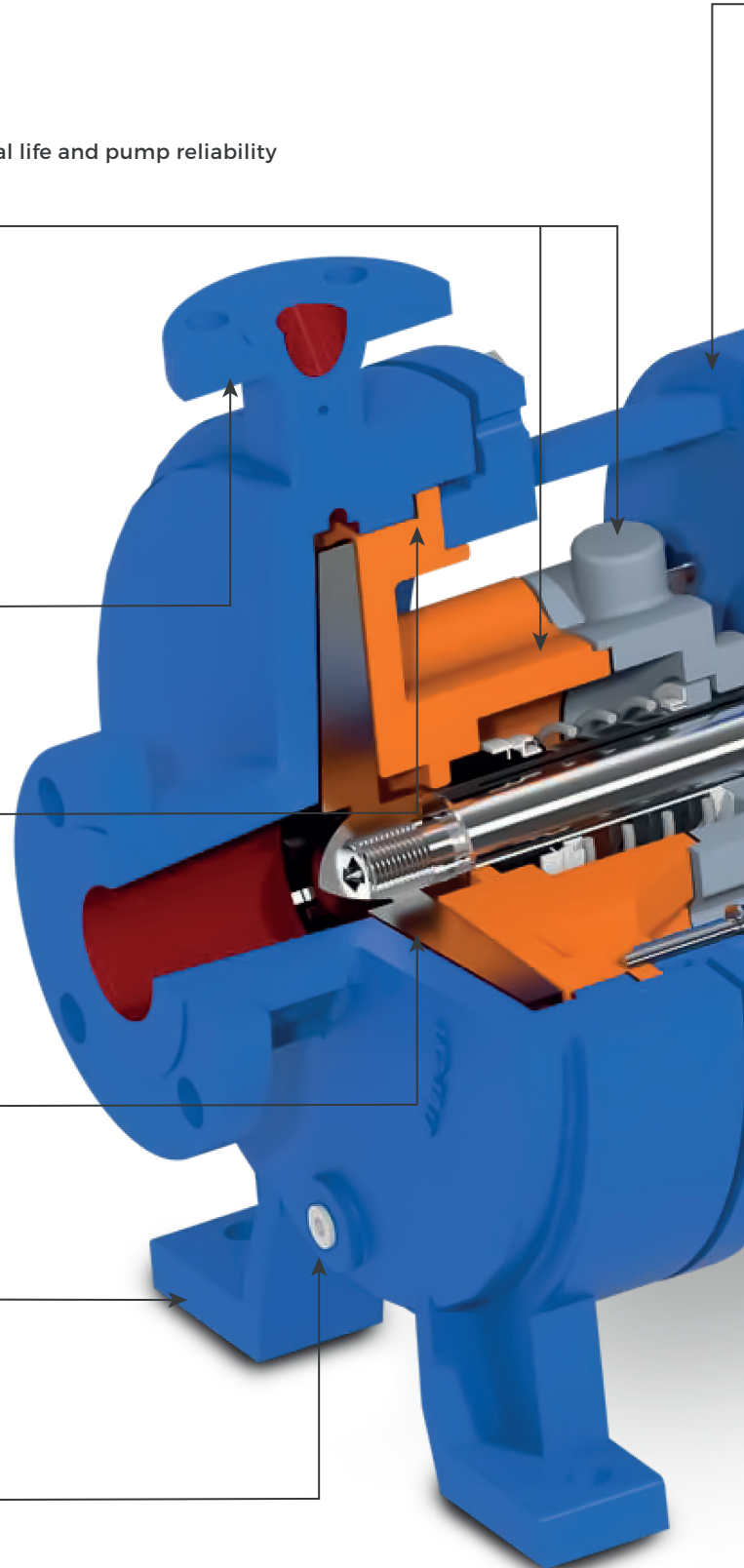

DELIVERY

Pumps / parts are strategically inventoried at various locations in North America, Asia for rush delivery in various material options.

PUMP SELECTOR PROGRAM

Helps to select & size the pumps for various applications. Please contact us for more details.

Adapter

- Standard Material: Ductile Iron
- Optional Material: Carbon Steel, 316SS (CF8M)

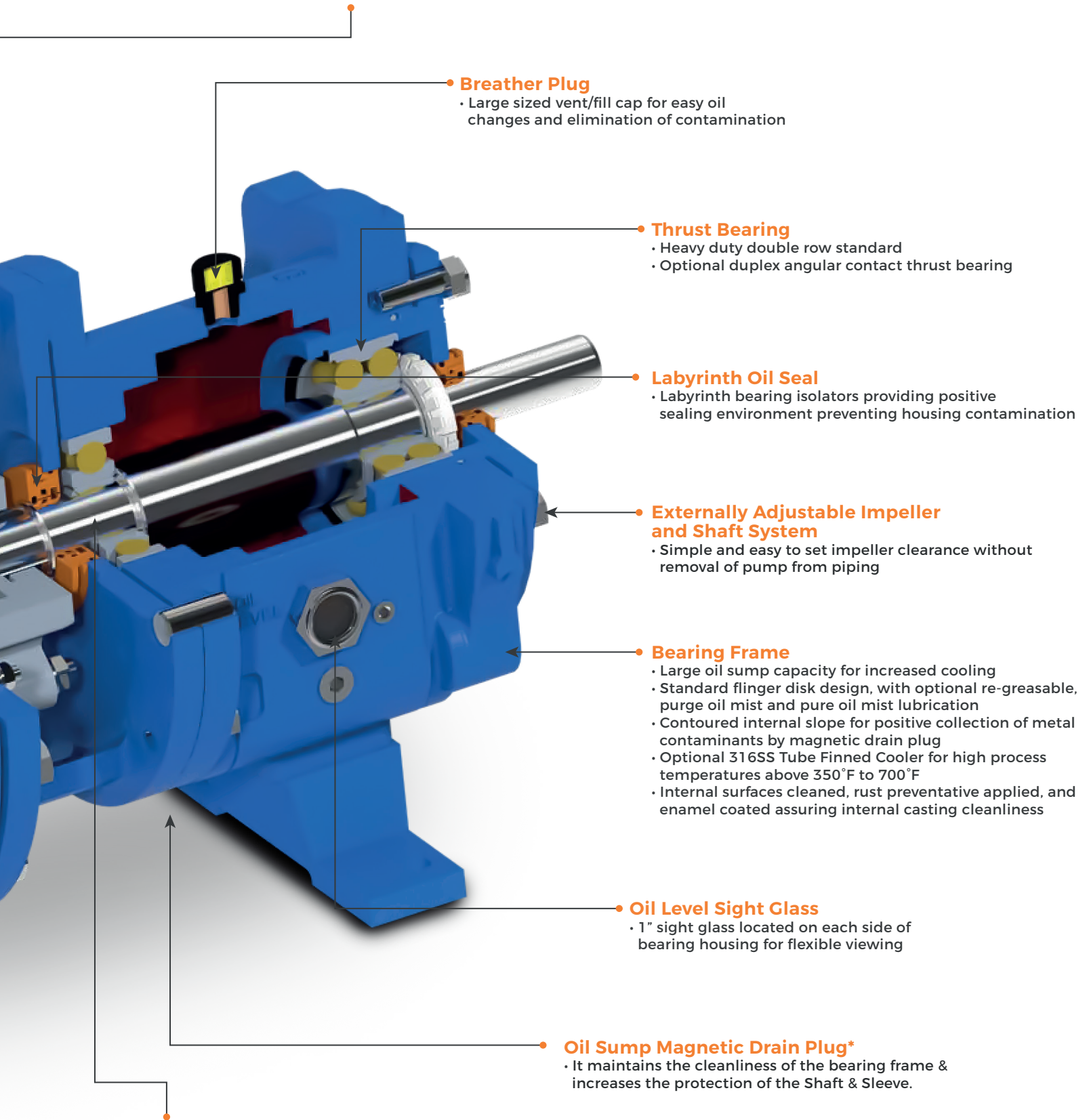

Breather Plug

- Large sized vent/fill cap for easy oil changes and elimination of contamination

Thrust Bearing

- Heavy duty double row standard
- Optional duplex angular contact thrust bearing

Labyrinth Oil Seal

- Labyrinth bearing isolators providing positive sealing environment preventing housing contamination

Externally Adjustable Impeller and Shaft System

- Simple and easy to set impeller clearance without removal of pump from piping

Bearing Frame

- Large oil sump capacity for increased cooling
- Standard flinger disk design, with optional re-greasable, purge oil mist and pure oil mist lubrication
- Contoured internal slope for positive collection of metal contaminants by magnetic drain plug
- Optional 316SS Tube Finned Cooler for high process temperatures above 350°F to 700°F
- Internal surfaces cleaned, rust preventative applied, and enamel coated assuring internal casting cleanliness

Oil Level Sight Glass

- 1" sight glass located on each side of bearing housing for flexible viewing

Oil Sump Magnetic Drain Plug*

- It maintains the cleanliness of the bearing frame & increases the protection of the Shaft & Sleeve.

Shaft and Sleeve

- Standard: Shaft AISI 4140 & Sleeve SS316
- Optional: Solid Shaft (MOC - 316SS, A2205, A2507, Alloy 20, Monel, Nickel, Hastelloy B, C & G, Titanium)
- Sleeve Shaft (MOC - 316SS, 316LSS, 2205, 2507)
- Rigid heavy duty design for minimum shaft deflection at seal area and increased reliability

Note: (*) Not Illustrated

HYDRAULIC PERFORMANCE COVERAGE

4 Pole Motor

Capacity up to 310 GPM (70 m³/h) | Head up to 225 feet (68 m) | Temperature to 700°F (371°C) Pressure up to 450 PSIG (3102 kPa)

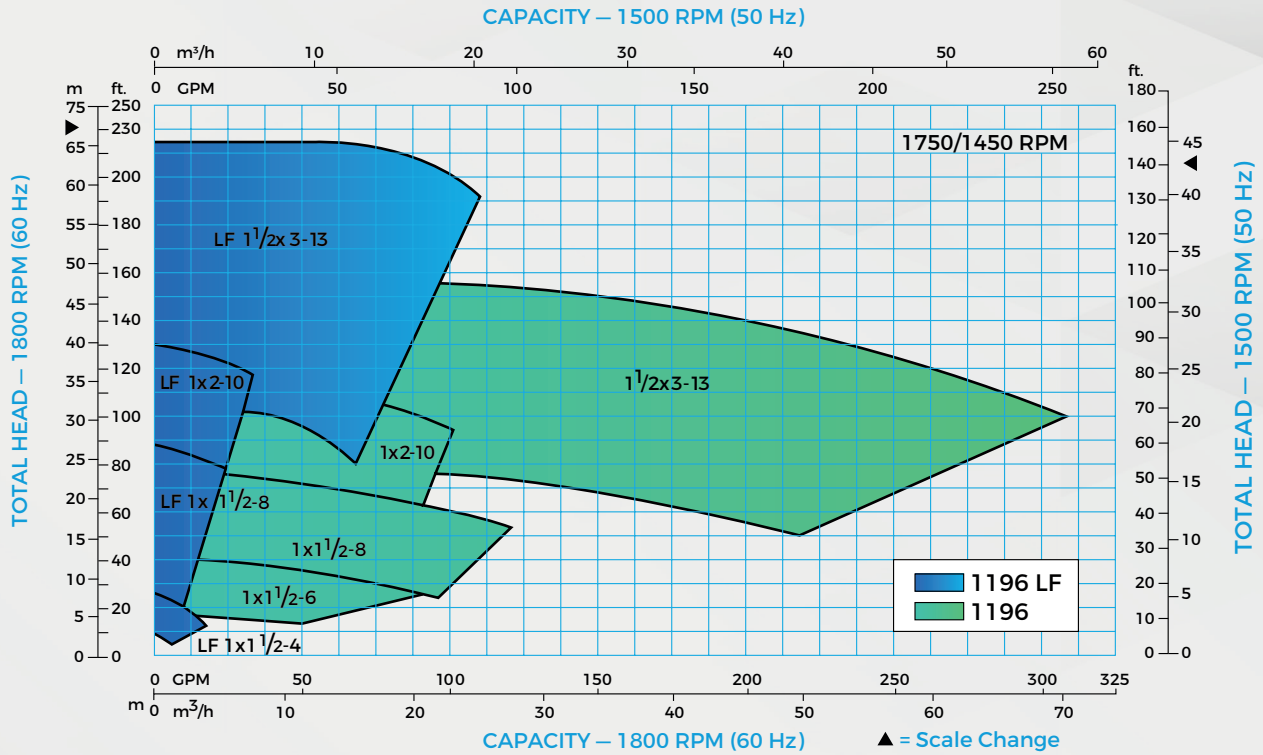

2 Pole Motor

Capacity up to 580 GPM (132 m³/h) | Head up to 925 feet (282 m) | Temperature to 700°F (371°C) Pressure up to 450 PSIG (3102 kPa)

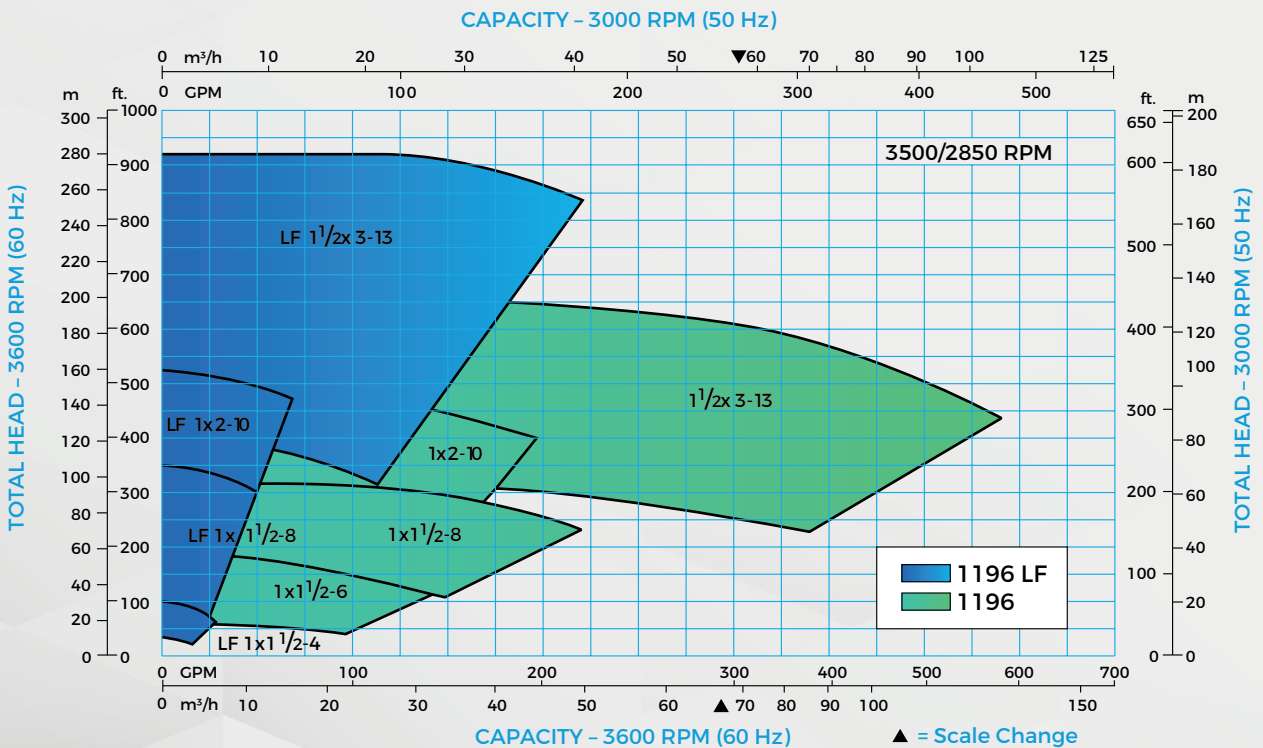

PUMP DIMENSIONS AND WEIGHT

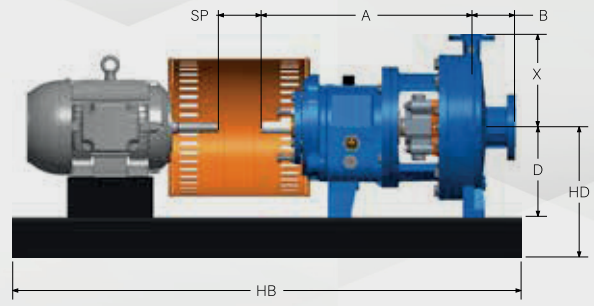
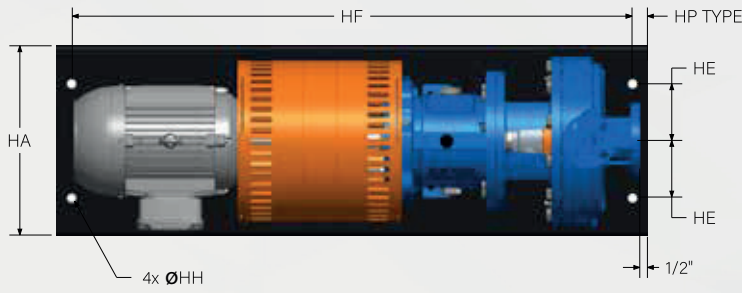

FRAME	SIZE	ANSI DESIGNATION	DISCHARGE SIZE	SUCTION SIZE	X	A	B	D	SP	WEIGHT BARE PUMP lb (kg)
STR	1x1.5-4									85(38)
	1x1.5-8									100(45)
MTR/LTR	1 x2-1 0	A05		2	8.5 (21 6)	19.5 (495)	4 (102)	8.25 (210)	3.75(95)	200 (91)-MTR 245 (111)- LTR
LTR	1.5x3-13	A20	1.5	3	10.2(267)	19.5 (495)	4 (102)	10 (254)	3.75(95)	285 (129)

BASE FRAME DIMENSIONS AND WEIGHT

NEMA MOTOR FRAME SIZE	ANSI BASE FRAME NUMBER	HA	HB	HD Max.			HE	HF	HH	HP (typ.)	WEIGHT lb (kg)
				D=5.25 (133)	D=8.25 (210)	D=10 (254)					
143T-184T	139	15 (381)	39 (991)	9 (229)			4.5 (114)	36.5 (927)	0.75 (19)	1.25 (32)	66(30)
213T-256T	148	18 (457)	48 (1219)	10.5 (267)			6 (152)	45.5 (1156)	0.75 (19)	1.25 (32)	82(37)
182T-184T	245	15 (381)	45 (1143)		12 (305)	13.75 (349)	4.5 (114)	42.5 (1080)	0.75 (19)	1.25 (32)	88(40)
213T-215T	252	18 (457)	52 (1321)		12.38 (314)	14.13 (359)	6 (152)	49.5 (1257)	0.75 (19)	1.25 (32)	106(48)
284T-286T	258	21(533)	58 (1473)		13 (330)	14.75 (375)	7.5 (191)	55.5 (1410)	1 (25)	1.25 (32)	179(81)
324T-326T	264	21(533)	64 (1626)		13.88 (353)	14.75 (375)	7.5(191)	61.5(1562)	1 (25)	1.25 (32)	218(99)
364T-365T	264	18 (457)	64 (1626)		13.88 (353)	14.75 (375)	7.5(191)	61.5(1562)	1 (25)	1.25(32)	172(78)

Weights and dimensions are approximate and not to be used for construction unless Certified By Manufacturer.

NEMA MOTOR DIMENSIONS AND WEIGHT

NEMA MOTOR FRAME	182T	184T	213T	215T	254T	256T	284T	286T	324T	326T	364T	365T	405T	444T	445T	447T	449T
Weight lb (kg)	98 (45)	128 (58)	197 (89)	226 (103)	375 (170)	412 (187)	495 (225)	519 (235)	700 (318)	756 (343)	948 (430)	1009 (458)	1330 (603)	1820 (826)	1893 (859)	2343 (1073)	3020 (1370)

PARTS LIST AND MATERIALS OF CONSTRUCTION

PART#	PART NAME	Ductile Iron w/ Carbon Steel Impeller	Ductile Iron w/ SS 316 Impeller	Carbon Steel	Carbon Steel w/ 316 SS Impeller	316SS	316L SS	Duplex SS	Super Duplex SS	Alloy 20 (Carpenter 20)	Monel	Nickel	Hastelloy B & C	Titanium	
100	Casing	DI	DI	WCB	WCB	CF8M	CF3M	CD4MCUN	SS Gr5A	CN7M	Monel	Nickel	Hastelloy B, C&G	Titanium	
101	Impeller	WCB	CF8M	WCB	WCB	CF8M	CF3M	CD4MCUN	SS Gr5A	CN7M	Monel	Nickel	Hastelloy B, C&G	Titanium	
106	Packing, Stuffing Box (Optional)	Teflon - Impregnated Fibers													
108	Adapter, Frame*	DI(Optional : Carbon Steel)										DI (Optional : Carbon Steel/CF8M)			
122	Shaft - Less Sleeve (Optional)	AISI4140				316 SS (Optional 316L SS, Alloy 20 & A2205)			A2205	A2507	Alloy 20	Monel	Nickel	Hastelloy B, C&G	Titanium
122	Shaft with Sleeve	AISI4140							316SS						
126	Shaft Sleeve	316SS (CF8M)					CF3M	CD4MCUN	Gr5A	CN7M	Monel	Nickel	Hastelloy B, C&G	Titanium	
134	Thrust Bearing Housing	DI(Optional : Carbon Steel)													
184	Cover, Stuffing Box (Packed Box)	DI	DI	WCB	WCB	CF8M	CF3M	CD4MCUN	SS Gr5A	CN7M	Monel	Nickel	Hastelloy B, C&G	Titanium	
184	Seal Chamber (Mechanical Seal)	DI	DI	WCB	WCB	CF8M	CF3M	CD4MCUN	SS Gr5A	CN7M	Monel	Nickel	Hastelloy B, C&G	Titanium	
228	Frame, Bearing	DI(Optional : Carbon Steel)													
250	Gland - Seal/Packing	WCB	WCB	WCB	WCB	CF8M	CF3M	CD4MCUN	SS Gr5A	CN7M	Monel	Nickel	Hastelloy B, C&G	Titanium	
319	Sight Glass - Oil	Glass/Steel													
332A	Labyrinth Seal (IB & OB)	Bronze													
351	Gasket, Casing	PTFE													
358	Plug, Casing Drain (Optional)	GI	GI	MS	MS	316 SS	316L SS	Duplex A2205	A2507	Alloy 20	Monel	Nickel	Hastelloy B, C&G	Titanium	
380F	Gasket, Frame to Adapter	Non-Asbestos Beater (NAB)													
412A	O-ring, Impeller	Glass Filled Teflon													
496	O-ring, Bearing Housing	Buna Rubber													
637	Breather Plug	Carbon Steel													

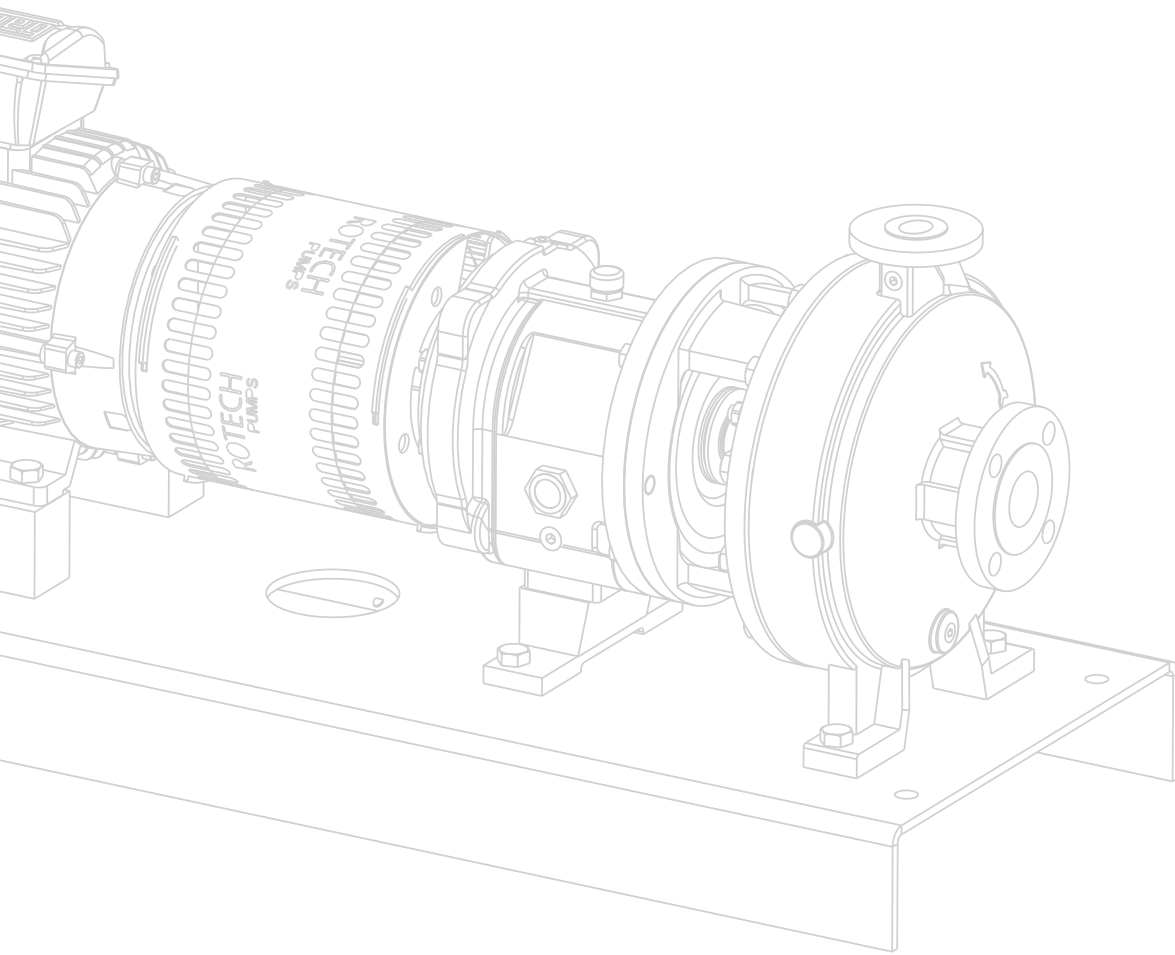

QUALITY | COMMITMENT | ADAPTABILITY

CANADA

Headquarters

1180 Britannia Road East,
Mississauga, Ontario, L4W 1C8

☎ 1 - 866 - 217 - 7867

✉ sales@rotechpumps.com



USA

Headquarters

4555 Brittmoore Road,
Houston, Texas, 77041

☎ 1 - 866 - 217 - 7867

✉ sales@rotechpumps.com

www.rotechpumps.com