

**Product Details**

Electrical Connection: 10Amp Plug & Lead supplied  
 : 230V, 5.9A, 1400W  
 Waste : 20mm with drain hose attached  
 Unit Controls : Switch for main power  
 : Carel controller with digital readout

ITEM NO.	PART NUMBER	DESCRIPTION	Rev	Drawing Number	QTY.
1	WCFS26SS-A002	Body	C	WCFS26SS-D002	1
2	WCFS26SS-A003	Gantry	D	WCFS26SS-D003	1
3	WCFS2xSS-CH-A001	Compressor Housing	C	WCFS2xSS-CH-A001	1

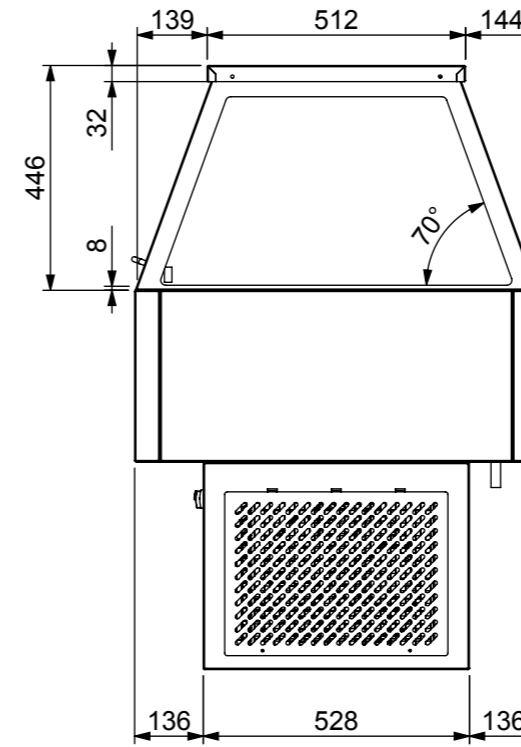
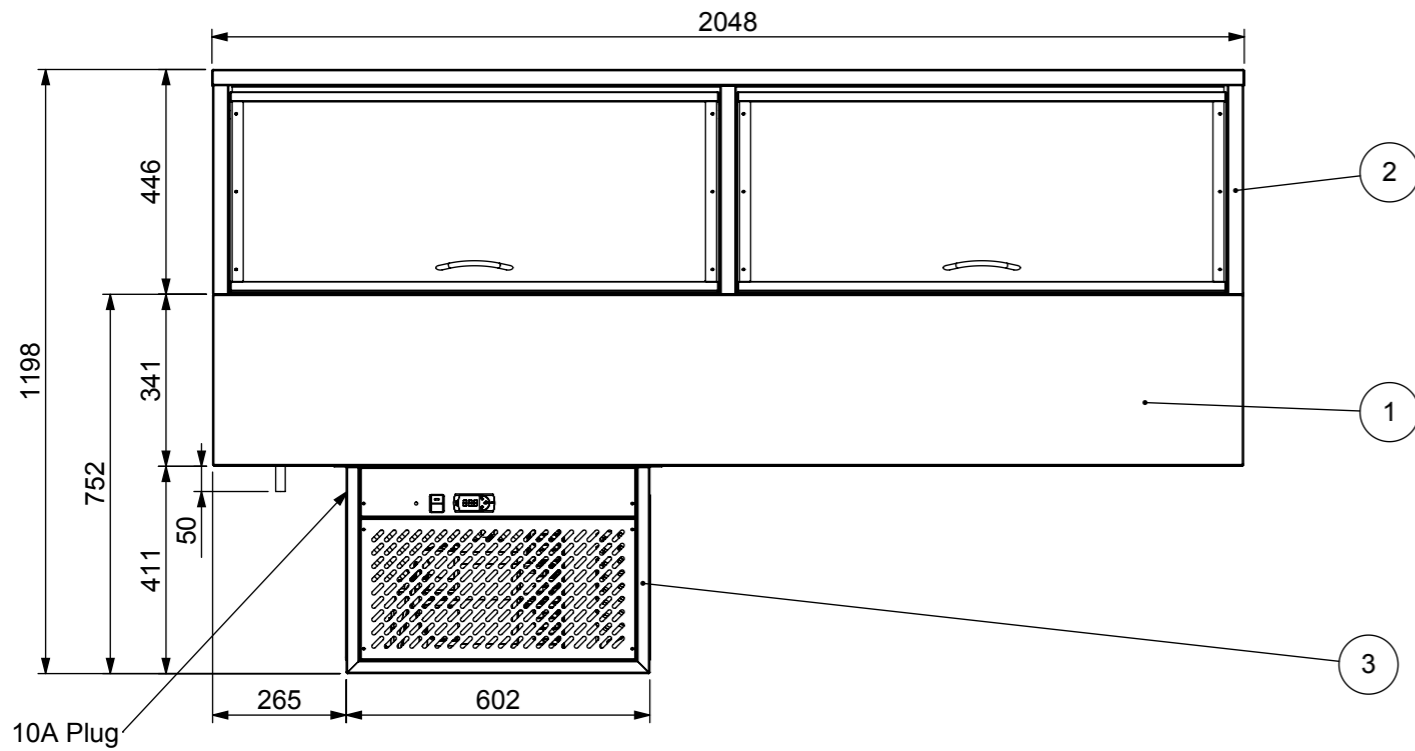
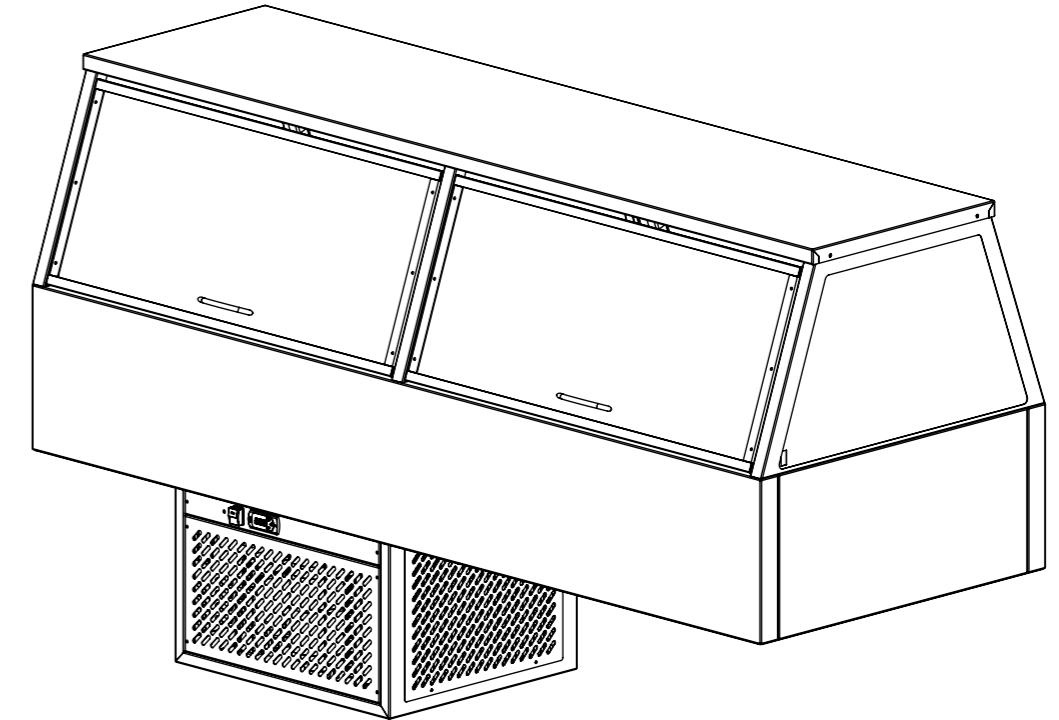
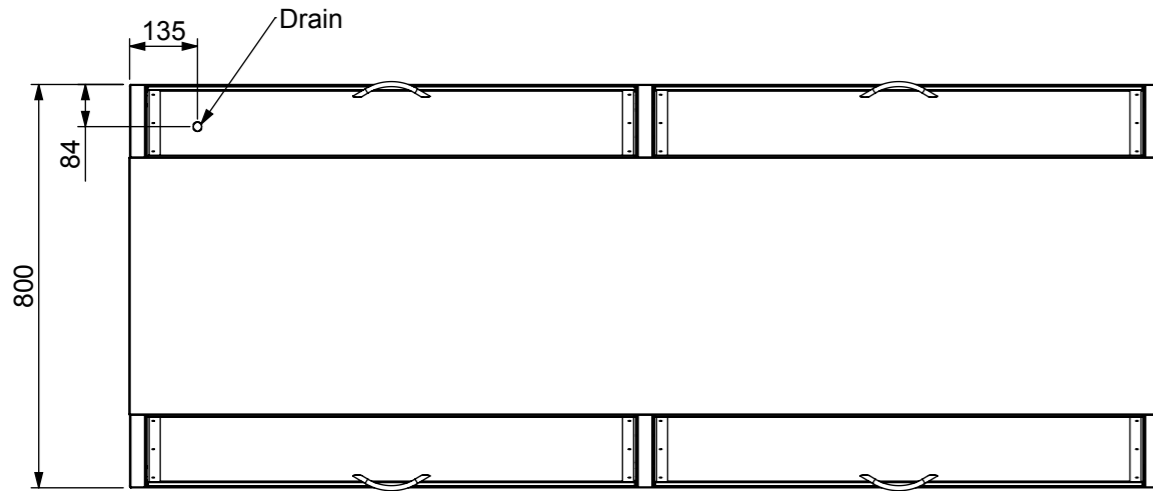

**STODDART MANUFACTURING**  
 TOM STODDART Pty Ltd ACN 009 690 251  
 215 Jackson Rd Sunnybank Hills Qld 4109  
 PO Box 420 Sunnybank Qld 4109  
 Phone (617) 3344 2444 Fax (617) 3345 6403  
 Email sunnybank@stoddart.com.au  
*Quality in stainless steel*

Woodson Self Serve Cold Food Bar				PART No: <b>WCFS26SS-A001</b>	
NAME	SIGNATURE	DATE	UNLESS OTHERWISE SPECIFIED: DIMENSIONS ARE IN MILLIMETERS	DESCRIPTION:	
DRAWN C Booth		23/11/2004			
APPVD			MATERIAL: THICKNESS: FINISH:	DWG No: <b>WCFS26SS-D001</b>	
Weight:				Dwg. Issue <b>4</b>	
Surface Area:			DO NOT SCALE DRAWING		
This drawing remains the property of Tom Stoddart Pty Ltd & cannot be reproduced without prior permission.			A3	Sheet 1 of 3	

REV.	REVISED BY	DATE	REVISION DESCRIPTION	STATUS
D	M Sheehan	23/08/2010	Door opening system changed to nylon roller guides and channel	
C	C Booth	05/09/2006	End profile angle changed from 72° to 70°	