

**Specification, Installation
and Operation Manual**

PIE AND FOOD DISPLAY

Models:
W.GPC62SC, W.GPC61SC, W.GPC350

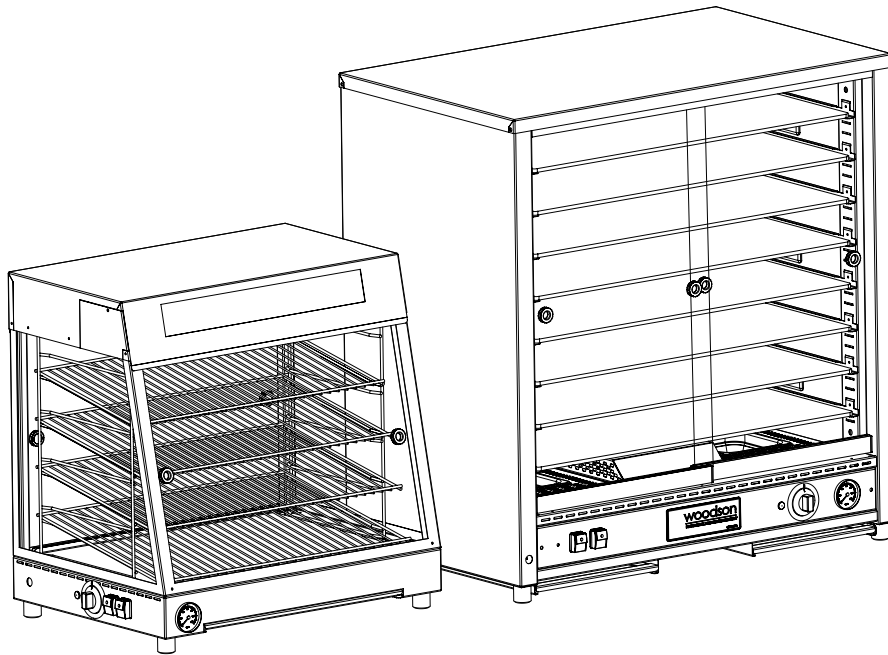

A guide on the use, care and maintenance
of your quality Woodson product

Introduction

Your New Woodson Product 3
 Product Overview. 3
 Attention 4
 General Information 4
 Service

Installation

Setting Up 5
 Handling
 Unpacking
 Positioning
 Electrical Connection 6
 Information

Specification

Technical Specifications 7
 W.PIA50
 W.PIA100
 W.PIP.200
 W.PIM.60

Operation

Control 11
 W.PIP.60
 W.PIP.200
 W.PIA.50 / W.PIA.100
 Operating Instructions 12
 Operation (W.PIP.60 / W.PIP.200)
 Operation (W.PIA.50 / W.PIA.100)
 Food Safety. 12
 Food Temperature
 Food Storage
 Cleaning 13
 General Information
 Corrosion Protection
 Surface Finish
 Cleaning Schedule
 Materials Required
 Cleaning Procedure
 Cleaning Procedure - External Surfaces
 Cleaning Procedure - External Surfaces Hard to remove soil (Stainless Steel Models only)
 Troubleshooting 15

Warranty

Appendix 1 – Australian Warranty and Contact Details 16

Australian Warranty Policy & Procedure. 16

1. Commercial Warranty 16

2. Consumer Warranty 16

3. Warranty Clarification 16

4. Warranty Claim Procedure 17

5. Timing of Warranty Services 17

6. General Maintenance and Repairs 17

Warranty Request Form 18

Your New Woodson Product

Thank you for choosing this quality Stoddart Woodson product. All our products are designed and made to meet the needs of food service professionals. By using, caring and maintaining your product according to these instructions, your Woodson product should give you many years of reliable service.

Woodson is a wholly Australian owned company, which has manufactured quality commercial catering equipment since 1954. All Woodson products are engineered and manufactured to give excellent results whilst offering value-for-money, ease-of-use and reliability.

Woodson manufacture a comprehensive range of equipment for kitchens, food preparation and presentation. Our range includes toasters, griddles, food warmers, fryers, hot and cold food display cabinets and many other quality products.

Product Overview

Configuration may vary according to model.

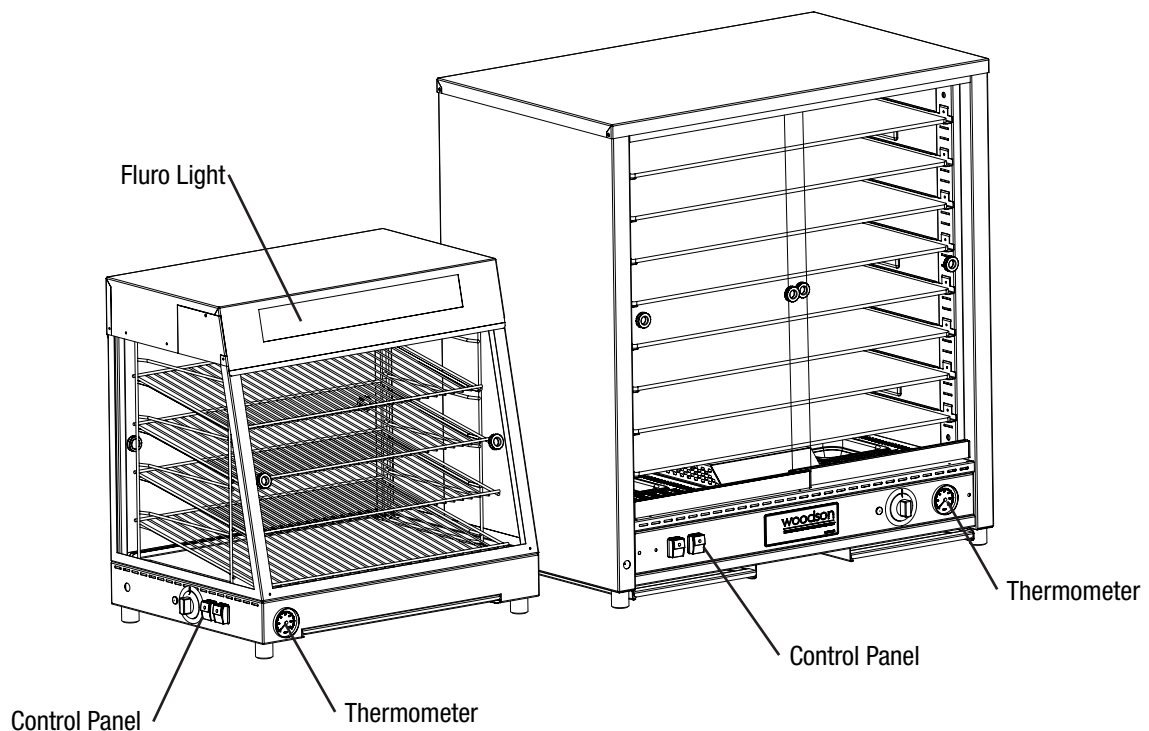
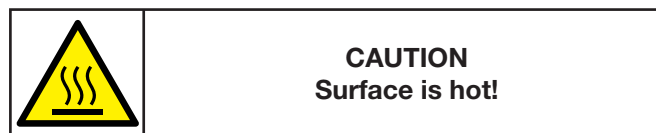

Attention

Carefully read this instruction booklet, as it contains important advice for safe installation, operation and maintenance. Keep this booklet on hand in a safe place for future reference by other operators or users.

Disclaimer

The manufacturer and distributor cannot be held responsible or liable for any injuries or damages of any kind occurred to persons, units or others, due to abuse and misuse of this unit in regards to installation, un-installation, operation, servicing or maintenance, or lack of conformity with the instructions indicated in this documentation.

All units made by the manufacturer are delivered assembled, where possible, and ready to install. Any installation, un-installation, servicing, maintenance and access or removal of any parts, panels or safety barriers that is not permitted, does not comply in accordance to this documentation, or not performed by a TRAINED AND AUTHORISED SPECIALIST will result in the IMMEDIATE LOSS OF THE WARRANTY.

The manufacturer cannot be held responsible or liable for any unauthorized modifications or repairs. All modifications or repairs must be approved by the manufacturer in writing before initiating. All modifications or repairs performed to this unit must be performed at all times by a TRAINED AND AUTHORISED SPECIALIST. ANTY.

Stoddart design, manufacture & distribute Food Service Equipment (appliances) exclusively for the commercial market. This appliance is not designed nor intended for household or domestic use & must not be used for this purpose.

This product is intended for commercial use, and in line with Australian electrical safety standards the following warnings are provided:

- This product is not intended for use by persons (including children) with reduced physical, sensory or mental capabilities, or lack of experience and knowledge, unless they have been given supervision or instruction concerning the use of the product by a person responsible for their safety. Children should be supervised to ensure that they do not play with the product
- If the supply cord is damaged, it must be replaced by the manufacturer, its service agent or similarly qualified persons in order to avoid a hazard

General Information

When using any electrical unit, safety precautions must always be observed.

Our units have been designed for high performance. Therefore, the unit must be used exclusively for the purpose for which it has been designed.

Read these instructions carefully and retain for future reference.

- All units MUST be installed according to the procedures stated in the installation section of this manual
- In the case of new personnel, training is to be provided before operating the equipment
- DO NOT use this unit for any other purpose than its intended use
- DO NOT store explosive substances such as aerosol cans with a flammable propellant in or near this unit
- Keep fingers out of "pinch point" areas
- This unit is NOT waterproof. DO NOT use jet sprays or hoses to the exterior of the unit
- Only use this unit with voltage specified on the rating label
- Do NOT remove any cover panels that may be on the unit
- DO NOT use sharp objects to activate controls
- If any fault is detected, refer to troubleshooting
- The manufacturer declines any liability for damages to persons and/or things due and to an improper/wrong and/or unreasonable use of the machine

Service

- Only specifically trained/qualified Technicians (Stoddart, one of our service agents, or a similarly qualified persons) should carry out any and all repairs, maintenance and services

Setting Up

Improper installation, adjustments, alterations, service or maintenance can cause property damage, injury or death.

Handling

- Use suitable means to move the unit: eg. A lift truck or fork pallet trucks (the forks should reach more completely beneath the unit)

Unpacking

- Check the unit for damage before and after unpacking. If unit is damaged, contact the distributor and manufacturer
- Should any item have physical damage, report the details to the freight company and to the agent responsible for the dispatch within seven (7) days of receipt. No claims will be accepted or processed after this period
- The unit is supplied fully assembled
- Remove all protective plastic film, tapes, ties and packers before installing and operating
- Clean off any remaining residue from the interior/exterior of the unit using a clean cloth dampened with warm soapy water

Positioning

- Choose an area that is well ventilated and provides access for future maintenance
- Place the unit on a level stable work surface capable of supporting its weight
- Do not position the unit in a wet area, an area with a lot of heat and steam or near flammable substances
- Allow an air gap between the unit and other objects or surfaces. We recommend a minimum gap of 100mm for normal operational use (if the unit is near any heat sensitive material we suggest you allow additional space)
- Please consult national and local standards to ensure that your unit is positioned in accordance with any existing requirement

Electrical Connection

	<p style="text-align: center;">WARNING! This unit must be installed in accordance with local electrical standards.</p>
---	---

Information

Aggregate electrical ratings of the Unit are expressed in kilowatts in this manual.

Single Phase Units:

Supplied with an appropriately rated plug and lead fitted and be indicated as:

- 10A plug & lead fitted
- 15A plug & lead fitted
- 20A plug & lead fitted

On-site Connection:

- The electrical supply must comply with the rating plate data
- Ensure that the unit is connected to a suitably rated and earthed power source
- Ensure that there is an isolation switch installed near the unit
- If the supply cord is damaged, it must be replaced by the manufacturer, its service agent or similarly qualified persons in order to avoid a hazard. Please contact Stoddart for parts and we will advise how to do this in order to avoid any electrical hazard
- The power cable should be dry and/or isolated from moisture or water

	<p style="text-align: center;">WARNING!</p> <p>Some procedures in this manual require the power to the equipment to be turned off and isolated. Turn the power OFF at the power point and unplug the power supply lead by the plug body. If the power point is not readily accessible turn the equipment off at the isolation switch or the circuit breaker in the switchboard.</p> <p>Attach a yellow “CAUTION-DO NOT OPERATE” tag. This must be performed where relevant unless the procedures specify otherwise.</p> <p style="text-align: center;">FAILURE TO DO SO MAY RESULT IN ELECTRIC SHOCK.</p>
---	---

Technical Specifications

W.PIA50

Specifications	
Model	W.PIA50
Height	495mm
Width	595mm
Depth	350mm
Power	1.25kW
AMPS	10A plug & lead fitted

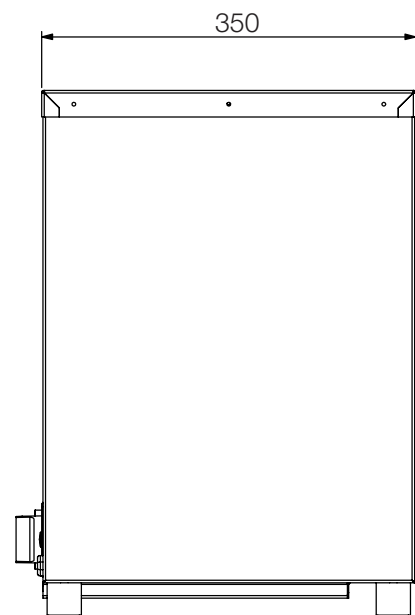
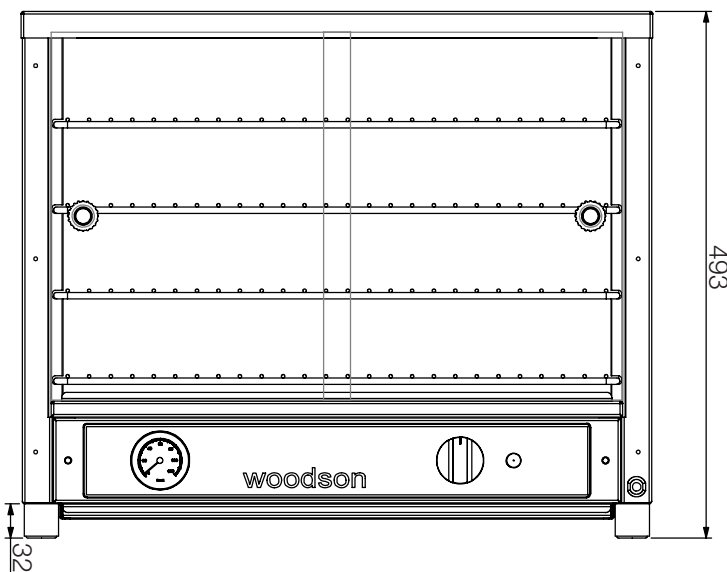
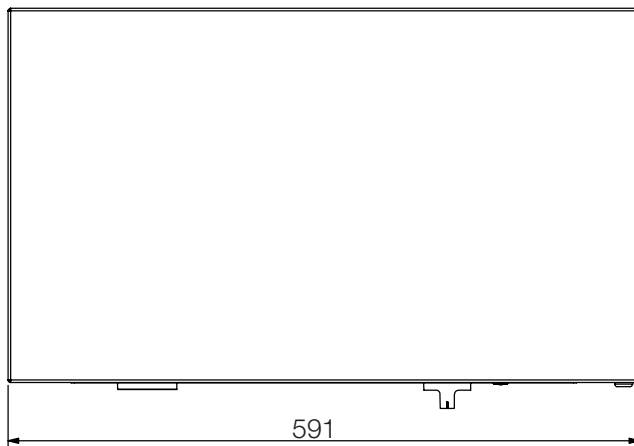

W.PIA100

Specifications	
Model	W.PIA100
Height	645mm
Width	755mm
Depth	350mm
Power	1.25kW
AMPS	10A plug & lead fitted

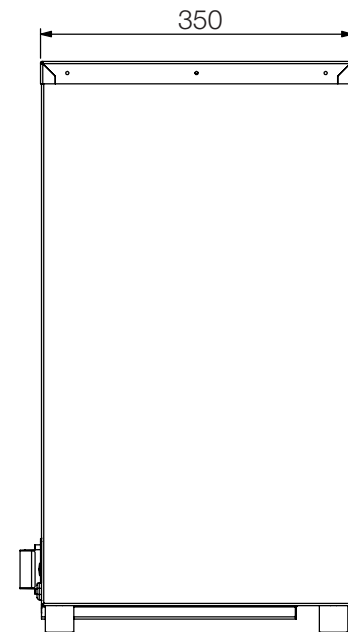
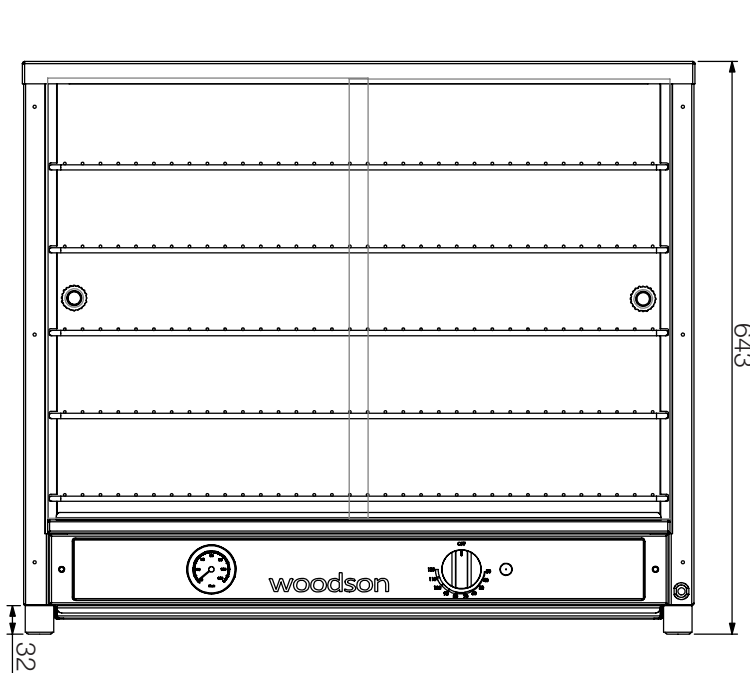
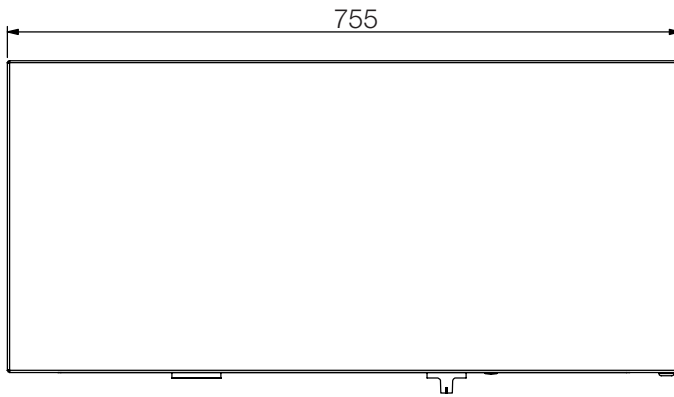

W.PIP.200

Specifications	
Model	W.PIP.200
Height	915mm
Width	870mm
Depth	530mm
Power	2.1kW
AMPS	10A plug & lead fitted

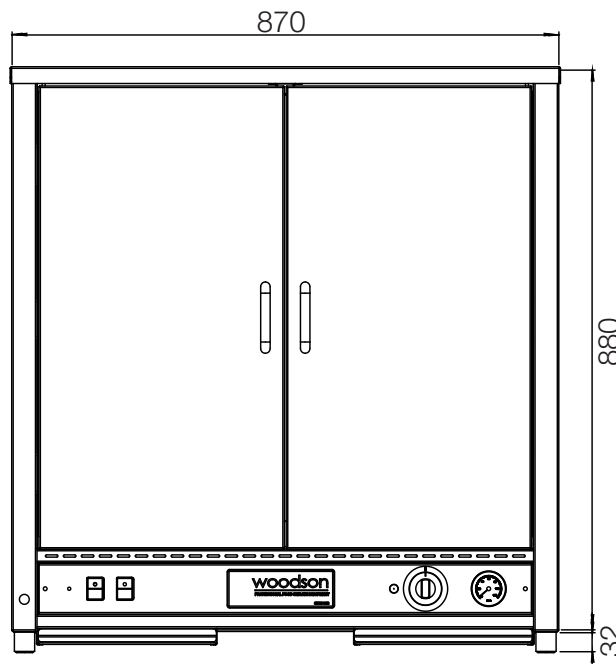
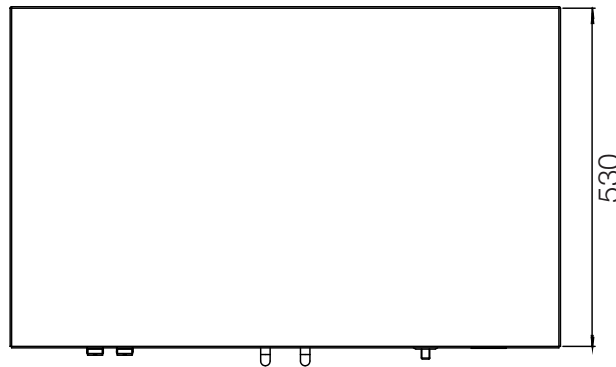

W.PIM.60

Specifications	
Model	W.PIM.60
Height	650mm
Width	665mm
Depth	465mm
Power	1.55kW
AMPS	10A plug & lead fitted

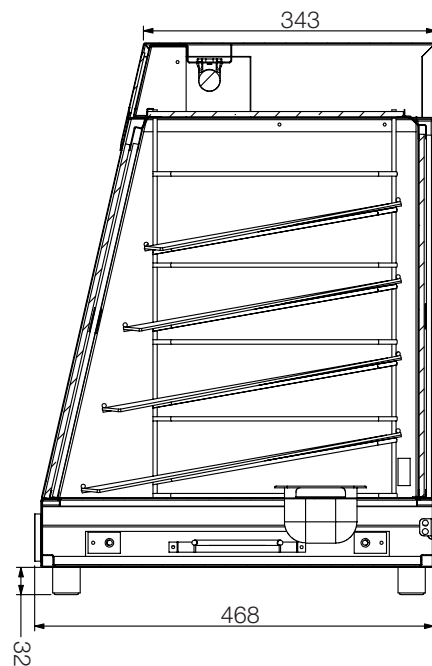
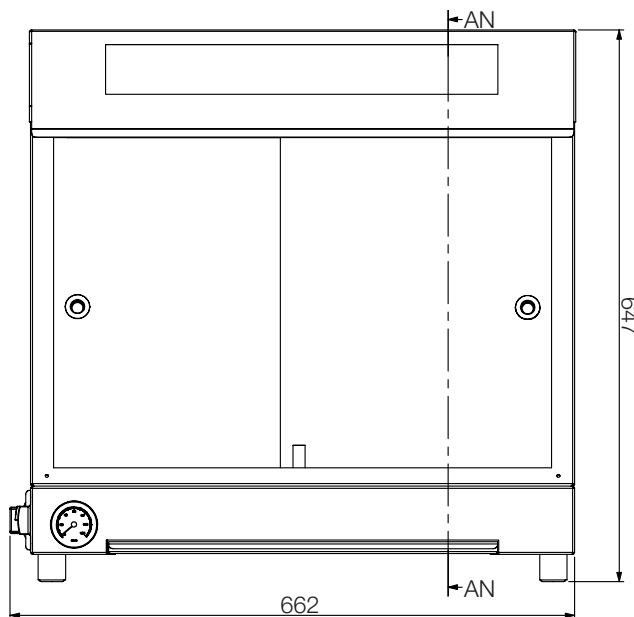
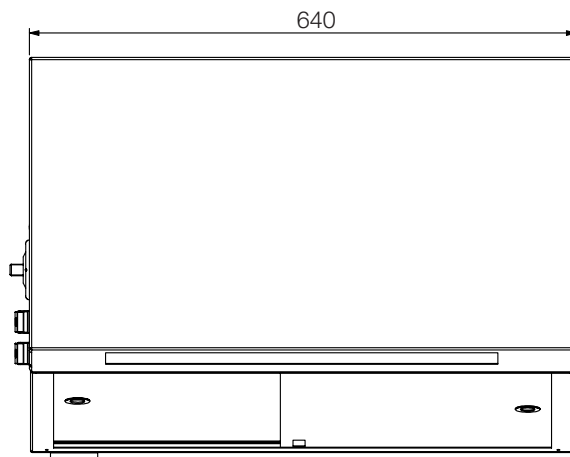

Control

W.PIP.60

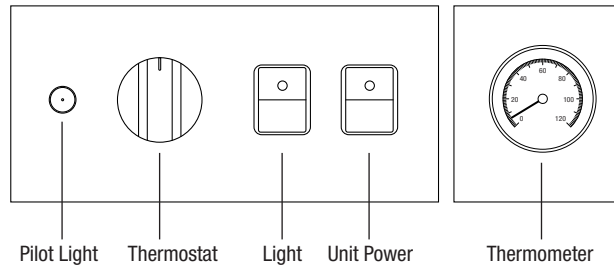

W.PIP.200

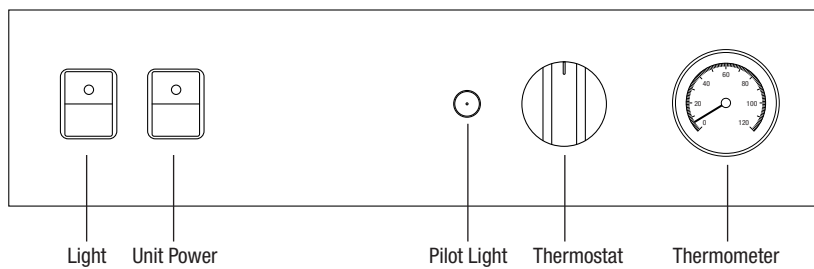

W.PIA.50 / W.PIA.100



Operating Instructions

Operation (W.PIP.60 / W.PIP.200)

Upon setting up your equipment, the following steps must be followed:

1. Prior to use Fill the humidity tray/s located at the bottom of the unit with water, monitor regularly to ensure appropriate water levels are maintained
2. Turn the unit on by pressing the “Power ON/OFF” switch, the pilot light will be illuminated
3. Select the desired temperature by adjusting the “Thermostat”. The temperature will be shown on the “Thermometer”
4. For display lights, press the “Light Switch”

Operation (W.PIA.50 / W.PIA.100)

1. Turn the unit on by turning the “Thermostat” clockwise until the pilot light is illuminated
2. Select the desired temperature by adjusting the “Thermostat”. (The operating temperature is shown on the “Thermometer”)

Food Safety



Important!
This unit is not designed to cook products, it only maintains them above the regulated 65°C serving temperature.

Food Temperature

- All food **MUST** be pre-heated/cooked before placing in the unit. Attempting to cook food with this unit can lead to food poisoning
- Ensure the unit is maintaining the food temperature over 65°C
- The temperature reached on the temperature gauge is the air temperature, **NOT** the food temperature
- It is important to regularly monitor the food temperature

Food Storage

- All storage of food should comply with local health standards and regulations
- This unit is **NOT** designed to store product after hours. The unit **MUST** be switched OFF

Cleaning

General Information



- Cleaning is recommended for health and safety purposes and to prolong the life of the unit
- Do NOT use abrasive pads or cleaners on the stainless steel or any other metal parts of the unit
- Do NOT use industrial chemical cleaners, caustic based cleaners or bleaches and bleaching agents, many will damage the metals and plastics used on this unit
- When drying, metal surfaces should be wiped with a soft cloth in the same direction as grained polish
- Do NOT remove any screws for cleaning. All internal sections of the unit are to be cleaned by a qualified technician
- This unit is NOT waterproof, do NOT hose, do NOT pour water directly onto the unit

Corrosion Protection

- Stainless steel exhibits good resistance to corrosion however, if not properly maintained stainless steel can rust and/or corrode
- Any sign of mild rust and/or corrosion should be thoroughly cleaned with warm soapy water and dried as soon as possible
- NEVER use abrasive pads or cleaners for cleaning
- All metal surfaces should be checked while cleaning for damage, scuffs or scrapes as these can lead to rust and further damage to the product
- Mild rust and/or corrosion can be treated with a commercial cleaning agent that contains citric/oxalic/nitric/phosphoric. Do NOT use cleaning agents with chlorides or other harsh chemicals as this can cause corrosion. After treatment, wash with warm (not hot) soapy water and dry thoroughly
- Thoroughly wipe the surfaces dry after cleaning and do NOT let water pool on the unit. Check crevices and folds for pooling
- If an abrasive product is used while cleaning, thoroughly dry the unit and leave in an open or oxidised area for the stainless steel protective layer to replenish
- When using, ensure all liquids and moisture is cleaned up straight away. Food liquids such as juices from vegetables and fruits should NOT be left on preparation surfaces
- Do NOT leave items on the stainless steel such as cutting boards, rubber mats and bottles

Surface Finish

- To protect the polish, stainless steel should be dried by wiping a dry soft cloth in the same direction as grained polish
- For NON-food contact surfaces, a light oil can be wiped on the surfaces with a cloth to enhance the stainless steel surface. Wipe in the direction of the grain
- Some commercial stainless stain cleaners can leave residue or film on the metal; this may trap fine particles of food on the surface, thus deeming the surfaces not food safe

	<p style="text-align: center;">WARNING! This unit is NOT waterproof, do NOT hose. Do NOT pour water directly onto the unit.</p>
	<p style="text-align: center;">Important! Some commercial stainless stain cleaners leave residue or film on the metal that may entrap fine particles of food, thus deeming the surface not FOOD SAFE.</p>
	<p style="text-align: center;">WARNING! Wait until the unit has cooled to a safe temperature before undertaking any cleaning or maintenance. Contact with hot surfaces can cause burns and serious injury.</p>

Cleaning Schedule

- Daily cleaning is required for the unit. This will help to maintain and prolong the efficiency of your unit
- The unit should be cleaned at the end of each work day

Materials Required

- Non Abrasive Cleaning pad
- Clean Sanitised Cloth
- Paper Towel
- Container of warm water
- Nylon Brush
- Appropriate PPE (Personal Protective Equipment)

Cleaning Procedure

1. Isolate the unit from the power supply
1. Remove GN pans, metal shelves/racks and wash separately in a dishwasher or kitchen sink, thoroughly wipe dry after cleaning, DO NOT allow to air dry.
2. Using a good quality nylon brush remove crumbs and small food items
3. Wipe clean using a cloth dampened (not wet) with clean warm soapy water until all soil has been removed
4. Using a clean sanitised cloth, thoroughly wipe the stainless steel and metal parts dry. Do NOT let water pool on the unit. Check crevices and folds.

Cleaning Procedure - External Surfaces

1. Isolate the unit from the power supply
2. Wipe clean using a cloth dampened (not wet) with clean warm soapy water until all soil has been removed
3. Using a clean sanitised cloth, thoroughly wipe the stainless steel and metal parts dry. Do NOT let water pool on the unit. Check crevices and folds.

Cleaning Procedure - External Surfaces Hard to remove soil (Stainless Steel Models only)

1. Isolate from the power supply
2. Wearing Personal Protective Equipment (PPE), apply Stainless Cleaner with a non abrasive cleaning pad to the external surfaces
3. Scrub any baked on soil with the cleaner pad in the same direction as grained polish
4. Wipe clean using a cloth dampened with clean warm water until all Stainless Cleaner and soil has been removed
5. Using a clean sanitised cloth, thoroughly wipe the stainless steel and metal parts dry. Do NOT let water pool on the unit. Check crevices and folds

Note: In some areas, particularly seaside environments, stainless steel can be subject to surface discolouration or “tea staining” This can be removed with an appropriate cleaning agent which contains 10% sodium citrate. Ask your supplier of cleaning chemicals for a suitable brand.

Troubleshooting

	<p>WARNING! Technician tasks are only to be completed by qualified service people. Check faults before calling service technician.</p>
---	---

Task Type - (O) = Operator
 (T) = Technician Task

Problem	Possible Causes	Task	Possible Corrective Action
Unit not heating	Unit not turned "on" at the power socket	O	Turn power to "on" at the power socket on the wall
	"On/Off" switch on the control panel	O	Switch on power "on/off switch" on the control panel
Food too cold	Temperature requires adjusting	O	Adjust Dials accordingly
Food too hot	Temperature requires adjusting	O	Adjust Dials accordingly
Unit not Hot	Element failure	T	Test & replace the element if necessary

Appendix 1 – Australian Warranty and Contact Details

As the exclusive manufacturer and distributor of Stoddart products in Australia, Stoddart would like to congratulate you on your purchase of a Stoddart product.

Stoddart design, manufacture & distribute Food Service Equipment (appliances) exclusively for the commercial market. These appliances are not designed nor intended for household or domestic use & must not be used for this purpose.

This product is intended for commercial use, and in line with Australian electrical safety standards the following warnings are provided:

- This appliance is not intended for use by persons (including children) with reduced physical, sensory or mental capabilities, or lack of experience and knowledge, unless they have been given supervision or instruction concerning the use of the product by a person responsible for their safety. Children should be supervised to ensure that they do not play with the product.
- If the supply cord is damaged, it must be replaced by the manufacturer, its service agent or similarly qualified persons in order to avoid a hazard. Please contact Stoddart for parts and we will advise how to do this in order to avoid any electrical hazard.

Australian Warranty Policy & Procedure

Stoddart is committed to providing a comprehensive and fair warranty for all of its equipment. The warranty incorporates a commercial manufacturers' warranty, together with the consumer warranty provisions of the National Consumer Protection Act (2009).

1. Commercial Warranty

- 1.1 Stoddart warrants to the original purchaser ("**Customer**") of equipment manufactured or distributed by Stoddart that for **12 months** from the date of installation of the equipment by Customer (the "**Warranty Period**"), any defect in workmanship or material will, subject to clauses 1.2 and 3, be:
 - a) Repaired without charge; or
 - b) In respect of any **Major Failure** which cannot be repaired, replaced or the purchase money refunded.
- 1.2 Stoddart will not be liable for any associated loss, damage or compensation claim resulting from any defect in workmanship or material, and such liability is expressly excluded from the operation of clause 1.1.

2. Consumer Warranty

- 2.1 Subject to clause 3, equipment supplied by Stoddart to Customer comes with guarantees that cannot be excluded under the Australian Consumer Law. Customer is entitled to a replacement or refund for a **Major Failure** and compensation for any other reasonably foreseeable loss or damage. Customer is entitled to have the equipment repaired, or replaced if the equipment fails to be of an **Acceptable Quality** and that failure does not amount to a Major Failure.

3. Warranty Clarification

- 3.1 Customer acknowledges and agrees:
 - i. A **Major Failure** occurs when the equipment suffers repeated and/or unexpected failure that cannot be repaired to Stoddart's satisfaction (acting reasonably) or which Stoddart considers (acting reasonably) renders the equipment unsafe or inoperable;
 - ii. Stoddart can only warrant the equipment will be of an **Acceptable Quality** when Customer uses the equipment in accordance with Stoddart's manufacturer's instructions or user manual ("**Instructions**"). Acceptable Quality does not imply a lifetime guarantee for the equipment;
 - iii. Certain components have a finite expected life, especially in a commercial or high-use environment. For example components such as refrigeration compressors, elements, thermostats/simmerstats, switches, fans, and temperature controllers can be expected to last up to **12 months** when used in accordance with the instructions;
 - iv. In a commercial environment, components such as lamps, fluorescent tubes, light bulbs, glass, silicone seals, gaskets and plastic components will require regular replacement. This is not covered by warranty and is at Customer's cost.;
 - v. The life of equipment may be adversely affected by misuse, neglect, unauthorised alteration, incorrect installation, power surges, accident, use of inappropriate chemicals, flooding, and acts of God;
 - vi. Proper maintenance and cleaning of equipment in accordance with the Instructions is essential to the equipment's effective operation;
 - vii. On site warranty services are limited to sites within 50km from the nearest Stoddart authorised service agent and service agent's reasonable travel costs must be paid by Customer prior to the commencement of the repairs;
 - viii. Additional labour costs will apply for service outside standard business hours of 8.00am to 4:30pm, Monday to Friday and on public holidays;
 - ix. Stoddart cannot guarantee the performance of equipment made specifically to Customer's design or specifications. Stoddart will, where reasonably possible, draw any issues arising from Customer's design or specifications to Customer's attention during the commissioning and/or manufacturing process; and
 - x. Customer must pay additional costs incurred by Stoddart as a result of Customer failing to provide suitable access to the equipment for inspection and service.

3.2 Stoddart's warranty liability under clauses 1 and 2 of these Terms exclude or do not cover:

- a) The matters acknowledged by Customer in clause 3.1;
- b) Situations where Stoddart is not satisfied (acting reasonably) the equipment or any part of the equipment has been used in accordance with the Instructions including misuse, neglect, unauthorised alteration, incorrect installation, power surges, accident, use of inappropriate chemicals, flooding, fire or act of God;
- c) Any consequential loss, damage or expense arising directly or indirectly from use of the equipment otherwise than in accordance with the Instructions;
- d) Any damage or malfunction arising from, or relating to, Customer's failure to properly maintain or clean the equipment in accordance with the Instructions;
- e) Damage caused to equipment during transportation, which is outside Stoddart's standard delivery conditions.
- f) Breakage or replacement of lamps, fluorescent tubes, light bulbs, glass, silicone seals, gaskets and plastic components.;
- g) Maintenance, repair or other works not undertaken by a Stoddart authorised service agent.
- h) Where remote refrigeration is connected by a person other than Stoddart to equipment produced by Stoddart, Stoddart cannot accept claims for repair of TX valves and control components, as the fault may arise from the installation of the remote refrigeration lines, equipment, and gas, by a party over which Stoddart has no control.
- i) Transportation costs associated with transporting the equipment to a Stoddart authorized service agent where Stoddart considers (acting reasonably) that repairs cannot be undertaken on-site; and
- j) Unless agreed to by Stoddart in writing to the contrary, warranty is not included in the sale price for goods sold to or installed in an overseas location.

4. Warranty Claim Procedure

4.1 The following procedure must be followed to claim under Stoddart's warranties:

- a) Refer to the trouble-shooting section of the Instructions to establish the nature of the fault. Check the equipment is plugged-in, turned-on or has no other valid reason for not operating.
- b) If step (a) does not overcome the issue, you should report the fault with the equipment to our service department (phone 1300 307 289 or fax 07 3344 6166). Our service department will assist you with further trouble-shooting. If our service department is unable to resolve the fault with the equipment they will request you complete a Stoddart Warranty Request Form and fax (07 3344 6166) or email (service@stoddart.com.au) it to us. This form can also be completed online (www.stoddart.com.au/warranty-claim).
- c) To complete a Stoddart Warranty Request Form you will require the following information:
 - I. Proof of purchase stating model number and date of purchase;
 - II. The serial number of the equipment (this is located on the ratings plate sticker);
 - III. A description of the fault/problem;
 - IV. Your company details including the exact location of the equipment; and
 - V. Any restrictions on times or methods of access to the equipment.

Stoddart will not arrange a warranty call out until it receives the above information from you in writing.

- d) Upon receipt of a properly completed Stoddart Warranty Request Form, Stoddart will check its records to confirm whether the equipment is eligible for warranty repair. If warranty repair is required, Stoddart will issue an OFFICIAL AUTHORISATION NUMBER and details of work to be carried out by a Stoddart authorised service agent. This authorisation number MUST be obtained before any work is carried out. Stoddart will not accept invoices for work carried out without an official authorisation number or by an unauthorised service agent.
- e) Customer must quote the official authorisation number on all correspondence and invoices relating to a warranty claim to ensure prompt processing by Stoddart.
- f) Customer must pay all costs associated with a call-out for work that is not related to warranty repairs or outside Stoddart's Terms immediately.

5. Timing of Warranty Services

5.1 Stoddart will comply with its warranty liabilities contained in these Terms in a timely manner.

6. General Maintenance and Repairs

6.1 The equipment must be repaired and maintained by a qualified technician. Stoddart's authorised service agents are experienced technicians who understand the equipment and carry commonly used spare parts. Contact Stoddart's national service number listed below for details of your nearest Stoddart authorised service agent.

**For Warranty, maintenance, spare parts and repairs, contact:
Tel: 1300 307 289 Fax: 07 3344 1000 email: service@stoddart.com.au**

Warranty Request Form

This form can also be completed online at: www.stoddart.com.au/warranty-claim.

WARRANTY REQUEST FORM

Phone: (07) 3440 7600 Int: +617 3440 7600
 Phone: 1300 307 289
 Fax: (07) 3344 1000 Int: +617 3344 1000
 Email: service@stoddart.com.au



To ensure we can provide the best possible service we require you to complete this form. Make, model and serial number, along with other essential information. To secure a call, you must also have an account with Stoddart or complete the credit card details below.

THIS FORM MUST BE COMPLETED OR WARRANTY CANNOT BE PROCESSED

Name of contact person on site: _____ Date: / /

Business/Organisation name: _____

Street Address: _____

Suburb: _____ State: _____ Post Code: _____

Phone (Site): _____ Mob: _____

Equipment Type: _____ Brand: _____

Model/PNC no.: _____ Serial no.: _____

Location (large sites only): _____ Open: _____ Close: _____

Date of purchase: / /

Company purchased from: _____

(please provide a copy of your tax invoice or delivery docket as proof of purchase)

Description of fault: _____

Has the following been checked (tick box if appropriate and checked)?

Electrical power supply Gas Water Supply

Name of person requesting warranty (please print): _____

CREDIT CARD DETAILS - Required as security against chargeable work (see note below)

Card type: Visa Mastercard

Cardholder name: _____ Card no.: _____

Signature: _____ Expiry Date: / /

PLEASE NOTE: Warranty call-outs take place Mondays to Fridays between 8.00 and 16.30 (except public holidays). Any calls outside these times will be subject to penalty rates. Certain items such as glass components and light fittings are not covered under warranty. Claims for non-covered parts, no faults found, travel over 50km or other items outside our standard terms and conditions will be chargeable. Any chargeable items will be COD terms – payable onsite.

**CREDIT CARD INFORMATION MUST BE PROVIDED AS SECURITY AGAINST FALSE WARRANTY CALL-OUTS.
 FAILURE TO DO SO WILL RESULT IN REQUEST BEING UNATTENDED.
 NORMAL BUSINESS HOURS ARE 8AM – 4.30PM MONDAY TO FRIDAY**

***Stoddart Sales
Servicing and Replacement***

Sales Department

Tel: 1300 791 954

Fax: (07) 3344 1000

Email: fseorders@stoddart.com.au

Service & Spares Department

Tel: 1300 307 289

Email: service@stoddart.com.au

Email: spares@stoddart.com.au