

**Product Details**

**Electrical Connection**

- 25A 1Ø + N + E (No plug supplied)
- 240v, 25Amps, 50Hz
- 12 elements @ 500w (80V)

**Unit Controls**

- Control Board for Speed and Temperature

**Oven Chamber**

- Chamber Width = 375mm
- Chamber Length = 600mm
- Chamber Entry/Exit Height = 40-85mm (Variable)
- Convoyor Belt Width = 356mm

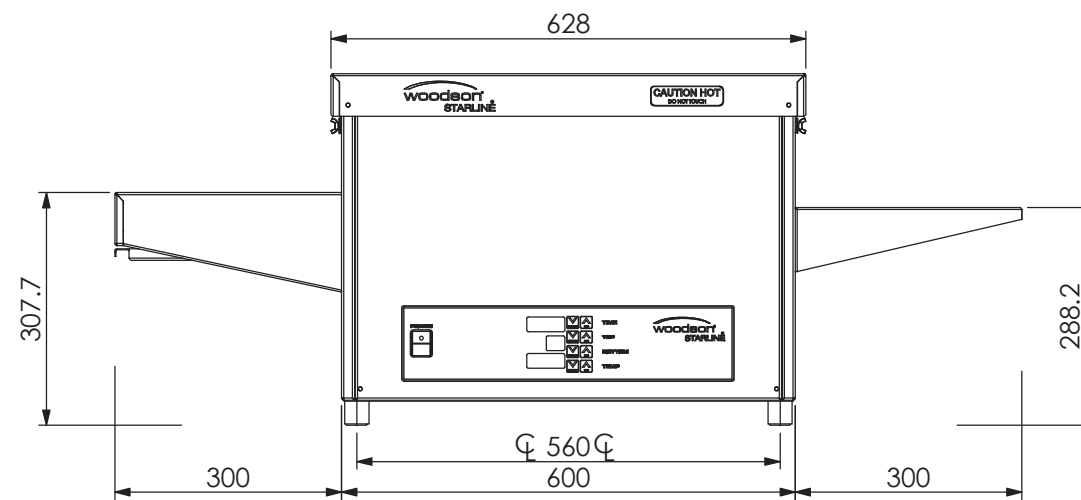
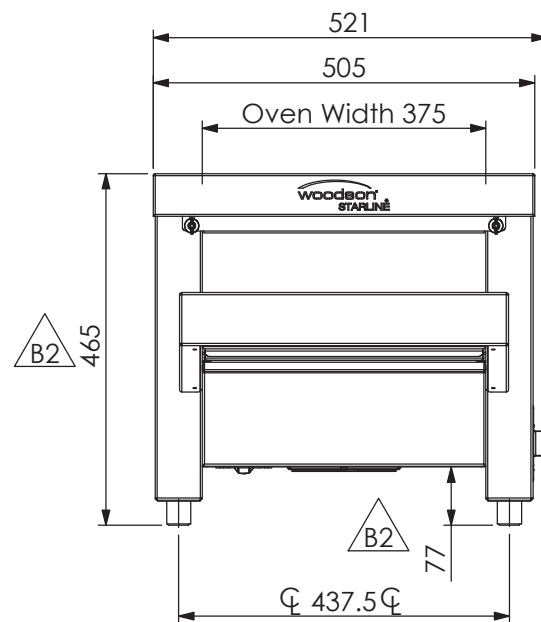
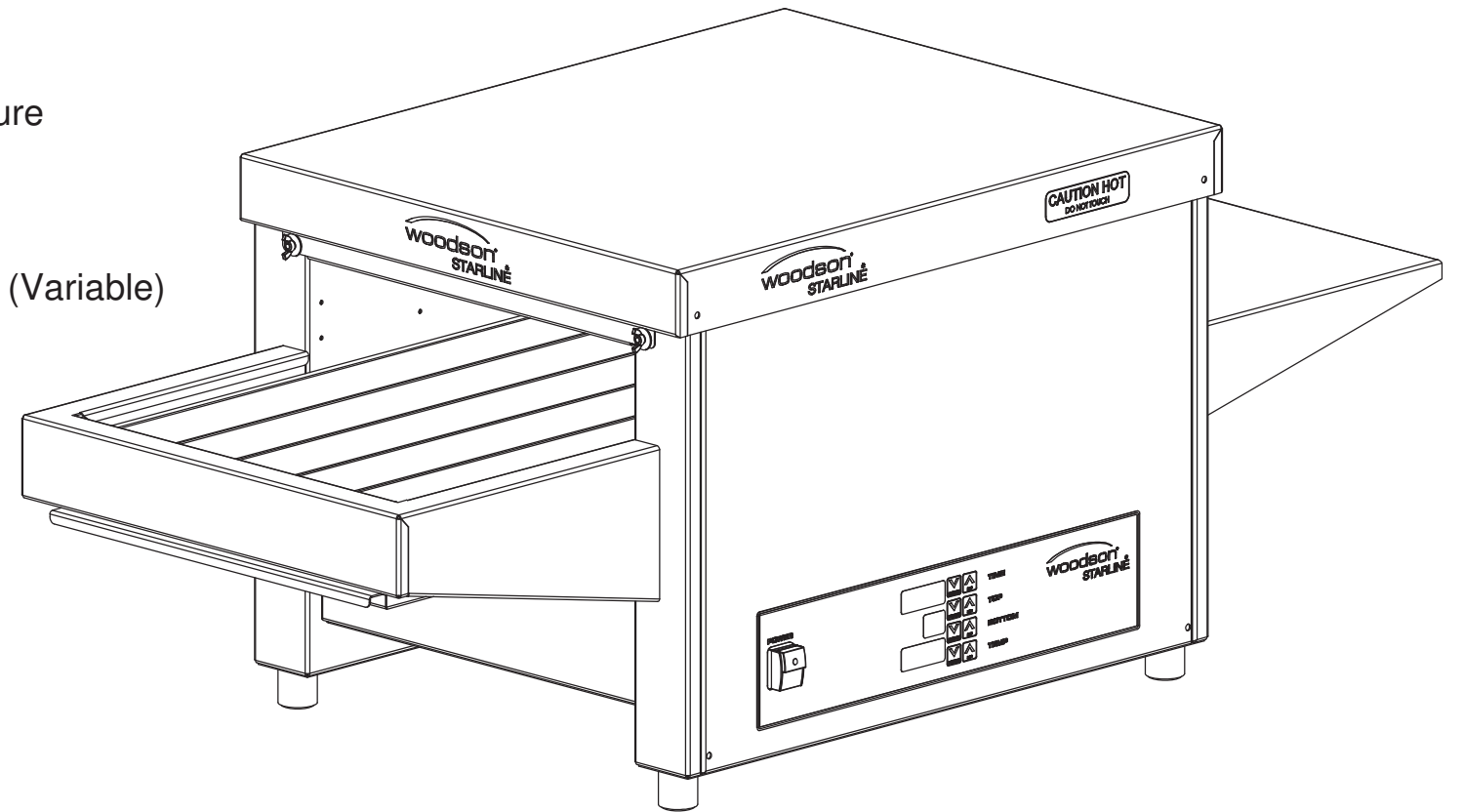

REV/VER.	REVISED BY	DATE	REVISION DESCRIPTION	STATUS
B1	W Preece	6/07/2016	Redesign of Starline Product	For Manufacture
B2	JeremyD	30/09/2016	Base Panel split and lifted 45mm. Dim 465 was 420	For Manufacture



www.stoddart.com.au

NAME	SIGNATURE	DATE	UNLESS OTHERWISE SPECIFIED: DIMENSIONS ARE IN MILLIMETERS
DRAWN W Preece		7/07/2016	
APPV'D			MATERIAL:
Weight:			THICKNESS:
Surface Area:			FINISH:

PART No:	<b>W-CVS-M-25 B2</b>
DESCRIPTION:	Woodson; Starline; Snackmaster M-25; 25Amp Conveyor Oven;
DWG No:	W-CVS-M-25-d01 B2
Dwg. Issue	<b>1</b>