



CR.CWCF.U.GSB.4

Refrigerated Well Counter Line

Under Bench



Product Information:

- This display is designed to be mounted under a custom made bench top of your choice (manufactured & fitted by others)
- Supports will be required to hold the cold well in position under the bench top
- Adjustable digital temperature controller allows food to be held between +2°C to +4°C in a maximum of 32°C ambient temperature
- The blown air design passes cold air over and under the food pans creating an even cooling effect
- Fitted with a stainless steel gantry support frame and light surround
- 10mm toughened flat glass gantry fitted with high impact, low energy L.E.D. lighting
- Gantry is detachable and height adjustable for ease of installation. To be connected by an electrician
- Fully insulated and constructed from 304 grade stainless steel with a No.4 finish
- Undermount refrigeration unit supplied with condensate drain hose for connection to waste
- Suits gastronorm pans up to 100mm deep (sold separately)

Product Code:

CR	= Culinaire Refrigerated
CWCF	= Cold Well - Counter Line - Fan Forced
U	= Under Bench
GSB	= Flat Glass Gantry - Black Painted Centre Section - Adhesive Fixed
4	= 4 Modules

Technical Data:

Dimensions: W x D x H:	1502 x 830 x 1095
Cutout Dimensions:	1395 x 545
Total Connected Load:	0.82kW
Electrical Connection:	10A plug & lead fitted

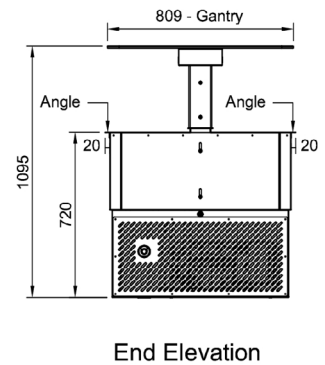
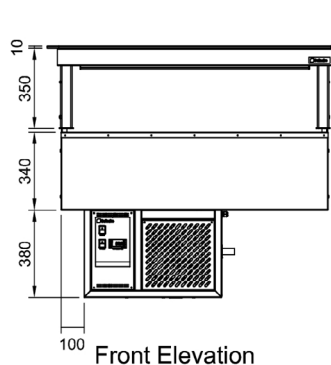
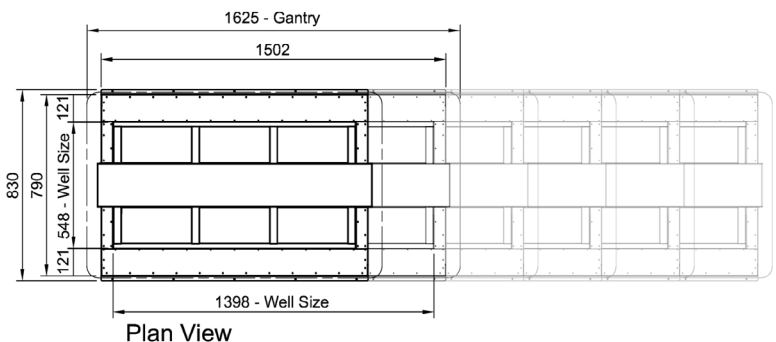

Proudly Manufactured in Australia

Due to continuous product research and development, the information contained herein is subject to change without notice

Manufactured By:

Tom Stoddart Pty Ltd. ABN 16 009690251
 39 Forest Way, Karawatha 4117 Queensland Australia
 Tel : +61 7 3440 7600 Fax : +61 7 33441000
 Web site: www.stoddart.com.au

