



## AXR.PM.1740

### Pizza Preparation Bench 2 Door - 9 x 1/3GN

#### Product Information:

- Angled refrigerated GN 1/3 size service well with cold air blowing above and below ingredient pans. Includes under counter refrigerated storage below
- Insulated tilting stainless steel night lids - fully removable
- Designed to operate at ambient temperatures up to 40°C with lid on, 32°C with lid open
- Digital temperature display and control
- Designed to operate between 2°C – 5°C
- Full-length, back mounted, coated evaporator coil for uniformed cooling across the entire well
- Fully self-contained
- Supplied on standard and lockable castors for ease of cleaning
- Pizza racks with dropping tray and 150mm deep 1/3 GN Pans supplied as standard
- 1 and 3 door models also available



**Designed and Engineered in Australia to meet Australian Standards**  
**24 Months on-site parts and labour warranty**

#### Specifications

<b>Model</b>	<b>AXR.SM.1740</b>
<b>W x D x H (mm)</b>	1740 x 895 x 1054
<b>Weight</b>	179kg
<b>Packed Dimensions (mm)</b>	1790 x 880 x 1150
<b>Packed Weight</b>	199kg
<b>Capacity</b>	9 x 1/3GN
<b>Operation</b>	2°C - 5°C
<b>Refrigerant</b>	R134A
<b>Max Ambient</b>	40°C
<b>Power</b>	1.73kW 230VAC 10A plug & lead

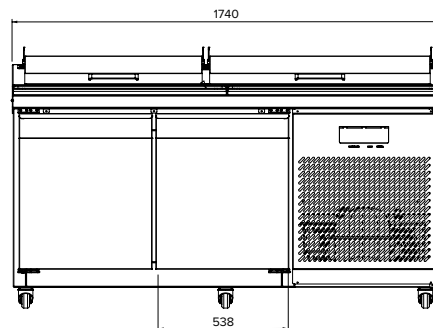

FRONT VIEW

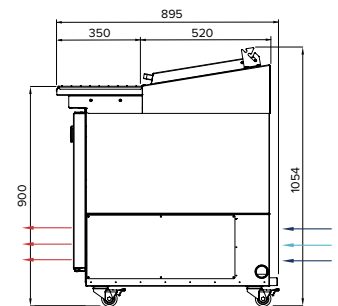

SIDE VIEW

Due to continuous product research and development, the information contained herein is subject to change without notice.

Revision: 01 - 23/07/2021 - A

[www.stoddart.com.au](http://www.stoddart.com.au)  
[www.stoddart.co.nz](http://www.stoddart.co.nz)

**INDUSTRY  
KITCHENS**

[www.industrykitchens.com.au](http://www.industrykitchens.com.au) 1800 611 058

