

Modular Cooking Range Line
EVO900 800mm Electric Fry Top,
Smooth and Ribbed Brushed
Chrome Sloped Plate

ITEM # _____

MODEL # _____

NAME # _____

SIS # _____

AIA # _____

**392358 (Z9IIMDAOMEA)**

Full module electric fry top with 2/3 smooth and 1/3 ribbed brushed chrome cooking plate, sloped, thermostatic control, scraper included

392359 (Z9IIMIAOMEA)

Full module electric fry top with 2/3 smooth and 1/3 ribbed brushed chrome cooking plate, sloped, 230V, thermostatic control, scraper included

Short Form Specification**Item No.** _____

2/3 smooth and 1/3 ribbed cooking surface in brushed chrome. Temperature range from 120°C to 280°C. To be installed on open base installations, bridging supports or cantilever systems. Removable drawer below the cooking surface for the collection of grease and fat. Body and work top of unit entirely in stainless steel with Scotch Brite finish. Extra strength work top in heavy duty 2 mm stainless steel. Right-angled side edges to allow flush-fitting junction between units.

Main Features

- Large drain hole on cooking surface permits the draining of fat into large 1 liter collector placed under the cooking surface.
- Electric elements in incoloy positioned under the cooking plate.
- Safety thermostat and thermostatic control.
- Units have separate controls for each half module of the cooking surface.
- Stainless steel high splash guards on the rear and sides of cooking surface. Splash guards can be easily removed for cleaning and are dishwasher-safe.
- The special design of the control knob system guarantees against water infiltration.
- IPX5 water protection.
- Unit to be mounted on open base cupboards, bridging supports or cantilever systems.
- Temperature range from 120° up to 280°C.
- Rough brushed chrome surface is highly resistant to scratches and facilitates cleaning operations at the end of the day.
- Scrapers with smooth and ribbed blades included as standard.
- Suitable for countertop installation.

Construction

- All exterior panels in Stainless Steel with Scotch Brite finishing.
- AISI 304 stainless steel worktop, 2mm thick.
- Model has right-angled side edges to allow flush fitting joints between units, eliminating gaps and possible dirt traps.
- Unit is 900mm deep to give a larger working surface area.
- Cooking surface 15mm thick brushed chrome for optimum grilling results and ease of use.
- Cooking surface 2/3 smooth and 1/3 ribbed.

APPROVAL: _____



Modular Cooking Range Line EVO900 800mm Electric Fry Top, Smooth and Ribbed Brushed Chrome Sloped Plate

Included Accessories

- 1 of Scraper for smooth plate for fry tops PNC 164255
- 1 of Scraper for ribbed plate fry tops - kit includes knife blades for both smooth and ribbed surface PNC 206420

Optional Accessories

- Scraper for smooth plate for fry tops PNC 164255
- Junction sealing kit PNC 206086
- Support for bridge type installation, 800 mm PNC 206137
- Support for bridge type installation, 1000 mm PNC 206138
- Support for bridge type installation, 1200 mm PNC 206139
- Support for bridge type installation, 1400 mm PNC 206140
- Support for bridge type installation, 1600 mm PNC 206141
- Side handrail for right/left hand PNC 206165
- Frontal handrail 800 mm PNC 206167
- Large handrail (portioning shelf) 800 mm PNC 206186
- Frontal handrail 1200 mm PNC 206191
- Frontal handrail 1600 mm PNC 206192
- 2 side covering panels, height 250 mm, depth 900 mm PNC 206321
- Grease/oil container kit for frytops PNC 206346
- Base support for feet or wheels - 800mm (EVO700/900) (only for 392358) PNC 206367
- Chimney grid net, 400mm PNC 206400
- Scraper for ribbed plate fry tops - kit includes knife blades for both smooth and ribbed surface PNC 206420
- Cloche for fry tops PNC 206455
- Water drain for full module fry top PNC 216153



Modular Cooking Range Line
EVO900 800mm Electric Fry Top, Smooth and Ribbed Brushed Chrome
Sloped Plate

The company reserves the right to make modifications to the products
without prior notice. All information correct at time of printing.

Front

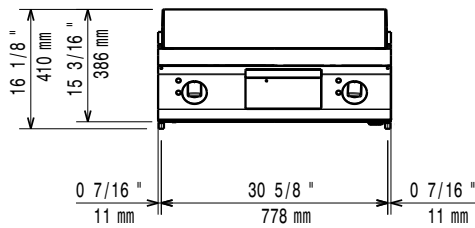

Side

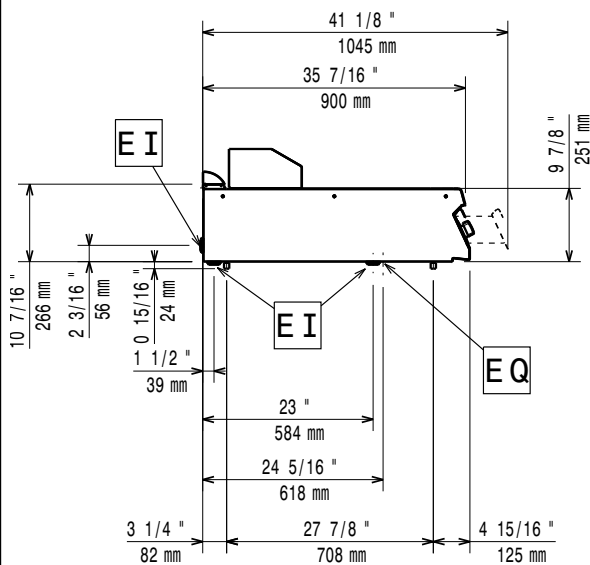

EI = Electrical inlet (power)
EQ = Equipotential screw

Top

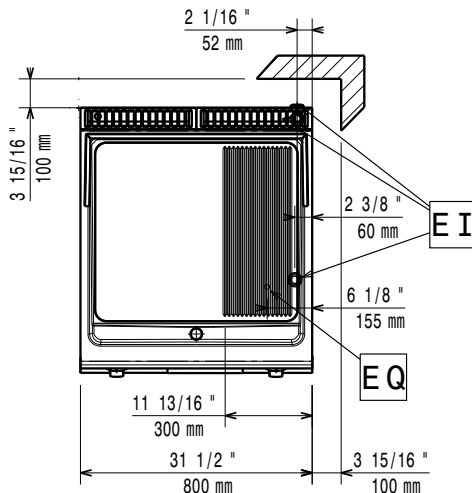

Electric

Supply voltage:

392358 (Z9IIMDAOMEA) 380-400 V/3 ph/50/60 Hz

392359 (Z9IIMIAOMEA) 230 V/3 ph/50/60 Hz

Total Watts:

15 kW

Predisposed for:

392358 (Z9IIMDAOMEA) 380-400V 3~ 50/60Hz
13,5-15kW

Key Information:

External dimensions, Width: 800 mm

External dimensions, Depth: 900 mm

External dimensions, Height: 250 mm

Net weight: 105 kg

Shipping weight:

392358 (Z9IIMDAOMEA) 98 kg

392359 (Z9IIMIAOMEA) 120 kg

Shipping height:

392358 (Z9IIMDAOMEA) 530 mm

392359 (Z9IIMIAOMEA) 540 mm

Shipping width:

392358 (Z9IIMDAOMEA) 1010 mm

392359 (Z9IIMIAOMEA) 900 mm

Shipping depth:

392358 (Z9IIMDAOMEA) 860 mm

392359 (Z9IIMIAOMEA) 1020 mm

Shipping volume:

392358 (Z9IIMDAOMEA) 0.46 m³

392359 (Z9IIMIAOMEA) 0.5 m³

If appliance is set up or next to or against temperature sensitive furniture or similar, a safety gap of approximately 150 mm should be maintained or some form of heat insulation fitted.