

**Modular Cooking Range Line
EVO900 2 Zone Electric
Induction Cooking Top**

ITEM # _____

MODEL # _____

NAME # _____

SIS # _____

AIA # _____



392277 (Z9INED2008)

2-zone (5 kW each) electric
induction cooking top**Short Form Specification****Item No.** _____

Glass ceramic cooking surface with 2 independently controlled 5 kW induction zones. Induction top surface with seamless transition between individual heating zones. Body and work top of unit entirely in stainless steel with Scotch Brite finish. Extra strength work top in heavy duty 2 mm stainless steel. Right-angled side edges to allow flush-fitting junction between units.

Main Features

- Glass ceramic cooking surface with 2 independently controlled induction zones with a power of 5 kW per zone.
- Almost the entire surface of the ceramic plate can be used without “dead” spots.
- One indicating lamp for each zone located on control console.
- Induction plates endowed with overheating safety device.
- Power to the individual zones can be set with progressive output i.e. fine regulation at the lower and larger progress at the upper levels.
- Low heat dissipation to the kitchen.
- The smooth, glass ceramic plate is not directly heated, so there is no burning on cooking surface.
- IPX5 water protection.
- Pots diameter to be used : min 12cm, max 28 cm in order to obtain maximum heating efficiency.
- Suitable for countertop installation.

Construction

- All exterior panels in Stainless Steel with Scotch Brite finishing.
- AISI 304 stainless steel worktop, 2mm thick.
- Model has right-angled side edges to allow flush fitting joints between units, eliminating gaps and possible dirt traps.
- Unit is 900mm deep to give a larger working surface area.

APPROVAL: _____

Optional Accessories

- Junction sealing kit PNC 206086
- Support for bridge type installation, 800 mm PNC 206137
- Support for bridge type installation, 1000 mm PNC 206138
- Support for bridge type installation, 1200 mm PNC 206139
- Support for bridge type installation, 1400 mm PNC 206140
- Support for bridge type installation, 1600 mm PNC 206141
- Support for bridge type installation, 400 mm PNC 206154
- Water column extension PNC 206290
- Chimney upstand, 400 mm PNC 206303
- 2 side covering panels, height 250 mm, depth 900 mm PNC 206321
- Stainless steel universal frying pan with stainless steel handle (diam. 200 mm) suitable for induction and all other heating sources PNC 653596
- Universal frying pan with stainless steel handle (diam. 240 mm) suitable for induction and all other heating sources PNC 653597
- Universal frying pan with stainless steel handle (diam. 280 mm) suitable for induction and all other heating sources PNC 653598

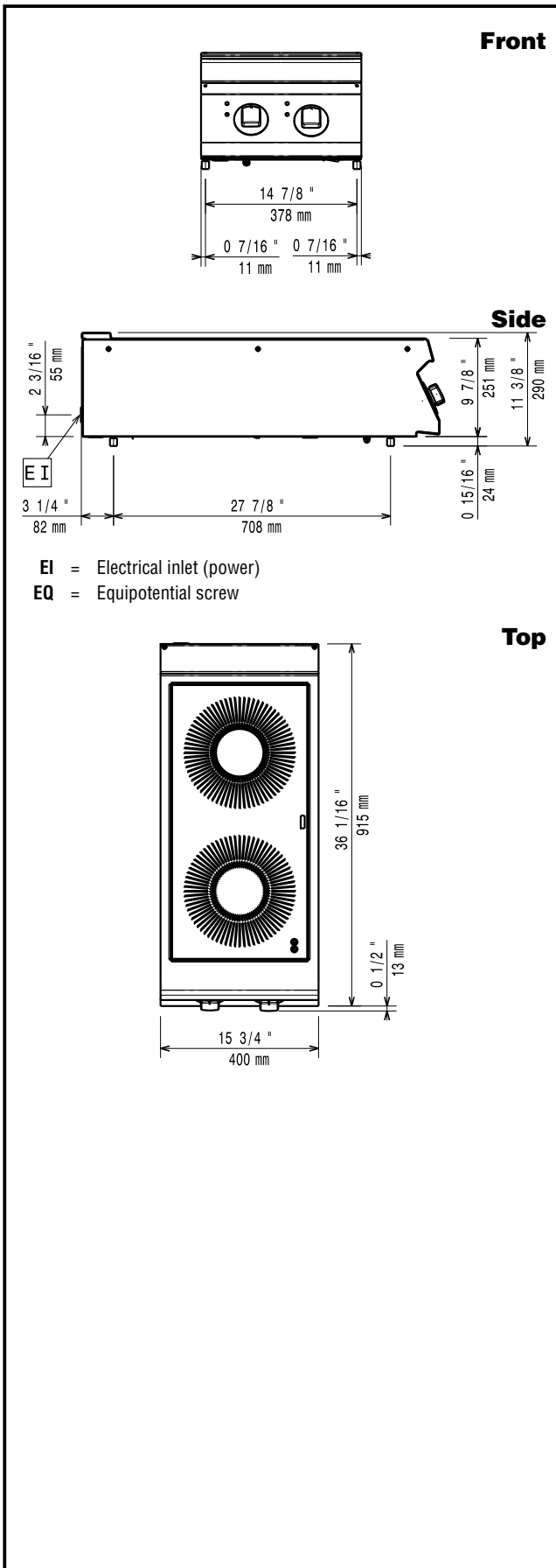

Electric

Supply voltage:	392277 (Z9INED2008)	380-415 V/3 ph/50/60 Hz
Total Watts:		10 kW
Predisposed for:		380-415V 3~ 50/60Hz 10kW

Key Information:

Induction Top Dimensions (width):	400 mm
Induction Top Dimensions (depth):	900 mm
Net weight:	40 kg
Shipping weight:	45 kg
Shipping height:	520 mm
Shipping width:	500 mm
Shipping depth:	1020 mm
Shipping volume:	0.27 m ³

Induction compatible pots & pans must be used.

Certification group: IH920

If appliance is set up or next to or against temperature sensitive furniture or similar, a safety gap of approximately 150 mm should be maintained or some form of heat insulation fitted.