

**Modular Cooking Range Line
EVO700 Half Module Electric
Char-Grill Top**

ITEM # _____

MODEL # _____

NAME # _____

SIS # _____

AIA # _____



372239 (Z7GREDGS0U) Electric grill top, half module

Short Form Specification**Item No.** _____

To be installed on open base installations, bridging supports or cantilever systems. Heating via incoloy armoured heating elements placed below the cooking plate. Cooking surface grids in enameled cast iron, easily removable for cleaning. Exterior panels in stainless steel with Scotch Brite finish. One piece pressed work top in 1.5 mm thick stainless steel. Right-angled side edges to allow flush-fitting junction between units.

Main Features

- Unit to be mounted on open base cupboards, bridging supports or cantilever systems.
- Heating via incoloy armoured heating elements below the cooking plate.
- Stainless steel high splash guards on the rear and sides of cooking surface. Splash guards can be easily removed for cleaning and are dishwasher-safe.
- Scraper for cleaning of grilling grids included.
- Cast iron grids can be adjusted on two levels.
- Energy regulation through a control knob.
- Heating element can be tilted frontally for easy cleaning.
- The low temperature of the external panels allow to work in safety.
- Cooking grids made in highly resistant enameled cast iron for easy cleaning.
- Suitable for countertop installation.

Construction

- All exterior panels in Stainless Steel with Scotch Brite finishing.
- One piece pressed 1.5 mm work top in Stainless steel.
- Model has right-angled side edges to allow flush fitting joints between units, eliminating gaps and possible dirt traps.
- IPx4 water protection.

APPROVAL: _____

Included Accessories

- 1 of Scraper for cast iron grills PNC 206422

Optional Accessories

- Junction sealing kit PNC 206086
- Support for bridge type installation, 800 mm PNC 206137
- Support for bridge type installation, 1000 mm PNC 206138
- Support for bridge type installation, 1200 mm PNC 206139
- Support for bridge type installation, 1400 mm PNC 206140
- Support for bridge type installation, 1600 mm PNC 206141
- Support for bridge type installation, 400 mm PNC 206154
- Frontal handrail 400 mm PNC 206166
- Frontal handrail 800 mm PNC 206167
- Large handrail (portioning shelf) 400 mm PNC 206185
- Large handrail (portioning shelf) 800 mm PNC 206186
- Frontal handrail 1200 mm PNC 206191
- Frontal handrail 1600 mm PNC 206192
- Right and left side handrails PNC 206240
- Chimney upstand, 400 mm PNC 206303
- 2 side covering panels, height 250 mm, depth 700 mm PNC 206320
- Chimney grid net, 400mm PNC 206400
- Stainless steel grids for free standing wide top grills (EVO700) PNC 206415
- Kit height adjustment support grill grids PNC 206418
- Scraper for grids with drainage channels - top grills PNC 206421
- Scraper for cast iron grills PNC 206422

Front

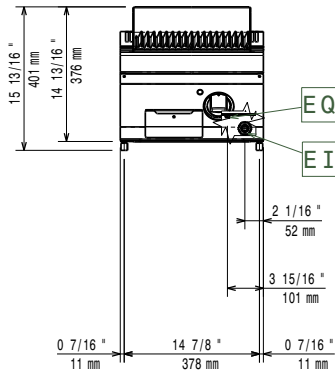

Side

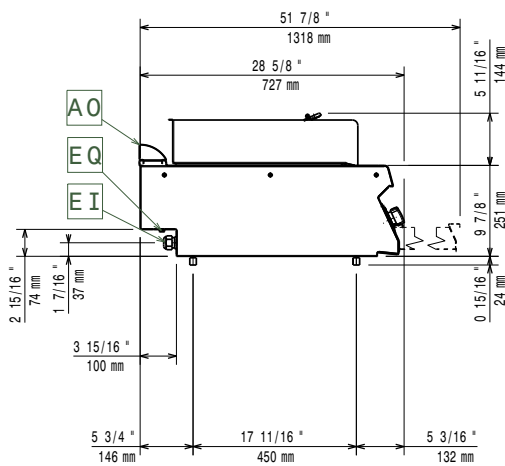

EI = Electrical inlet (power)
EQ = Equipotential screw

Top

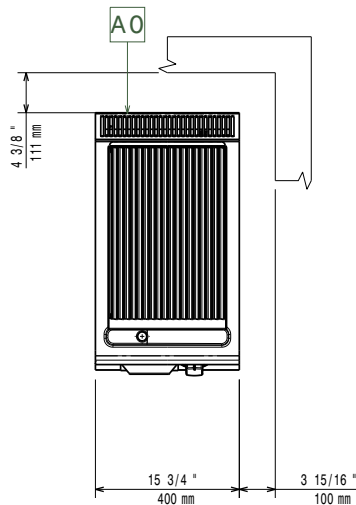

Electric

Supply voltage:	372239 (Z7GREDGS0U)	380-400 V/3N ph/50/60 Hz
Electrical power max.:		4 kW
Total Watts:		4 kW
Predisposed for:		380-400V 3N~ 50/60Hz 3,6-4kW

Key Information:

Cooking surface width:	316 mm
Cooking surface depth:	478 mm
Net weight:	32 kg
Shipping weight:	41 kg
Shipping height:	530 mm
Shipping width:	460 mm
Shipping depth:	820 mm
Shipping volume:	0.2 m ³

If appliance is set up or next to or against temperature sensitive furniture or similar, a safety gap of approximately 150 mm should be maintained or some form of heat insulation fitted.

Certification group: N7GE