

Modular Cooking Range Line
EVO700 Full Module Electric Fry
Top, Smooth and Ribbed Polished
Chrome Plate

ITEM # _____

MODEL # _____

NAME # _____

SIS # _____

AIA # _____

**372197 (Z7FTEHCPI0)**

Electric fry top with 2/3 smooth and 1/3 ribbed polished chrome cooking plate, thermostatic control, full module

372201 (Z7FTEHCPIN)

Electric fry top with polished chrome 2/3 smooth and 1/3 ribbed cooking plate, full module

Short Form Specification**Item No.** _____

To be installed on open base installations or bridging supports. 2/3 smooth and 1/3 ribbed polished chrome cooking surface. Temperature range from 120°C to 280°C. Removable drawer below the cooking surface for the collection of grease and fat. Exterior panels in stainless steel with Scotch Brite finish. One piece pressed work top in 1.5 mm thick stainless steel. Right-angled side edges to allow flush-fitting junction between units.

Main Features

- Unit to be mounted on open base cupboards, bridging supports or cantilever systems.
- Large drain hole on cooking surface permits the draining of fat into large 1,5 liter collector placed under the cooking surface.
- Large grease collection container available as optional accessory to be installed under top units over open base cupboard.
- Safety thermostat and thermostatic control.
- Stainless steel high splash guard on the rear and sides of cooking surface. Splash guard can be easily removed for cleaning.
- IPx4 water protection.
- Infrared heating elements mounted below the cooking surface.
- Frontal simmering zone.
- Polished chromium surface avoids the mixing of flavors when passing from one type of food to another.
- Temperature range from 120° up to 280°C.
- Suitable for countertop installation.

Construction

- All exterior panels in Stainless Steel with Scotch Brite finishing.
- One piece pressed 1.5 mm work top in Stainless steel.
- Model has right-angled side edges to allow flush fitting joints between units, eliminating gaps and possible dirt traps.
- Cooking surface 2/3 smooth and 1/3 ribbed.
- Cooking surface 12mm thick polished chrome for optimum grilling results and ease of use.

APPROVAL: _____

Included Accessories

- 1 of Scraper for smooth plate for fry tops PNC 164255
- 1 of Scraper for ribbed plate fry tops - kit includes knife blades for both smooth and ribbed surface PNC 206420

Optional Accessories

- Scraper for smooth plate for fry tops PNC 164255
- Junction sealing kit PNC 206086
- Support for bridge type installation, 800 mm PNC 206137
- Support for bridge type installation, 1000 mm PNC 206138
- Support for bridge type installation, 1200 mm PNC 206139
- Support for bridge type installation, 1400 mm PNC 206140
- Support for bridge type installation, 1600 mm PNC 206141
- Frontal handrail 800 mm PNC 206167
- Large handrail (portioning shelf) 800 mm PNC 206186
- Frontal handrail 1200 mm PNC 206191
- Frontal handrail 1600 mm PNC 206192
- Right and left side handrails PNC 206240
- Chimney upstand, 800 mm PNC 206304
- 2 side covering panels, height 250 mm, depth 700 mm PNC 206320
- Grease/oil container kit for frytops PNC 206346
- Base support for feet or wheels - 800mm (EVO700/900) PNC 206367
- Chimney grid net, 400mm PNC 206400
- Scraper for ribbed plate fry tops - kit includes knife blades for both smooth and ribbed surface PNC 206420
- Cloche for fry tops PNC 206455

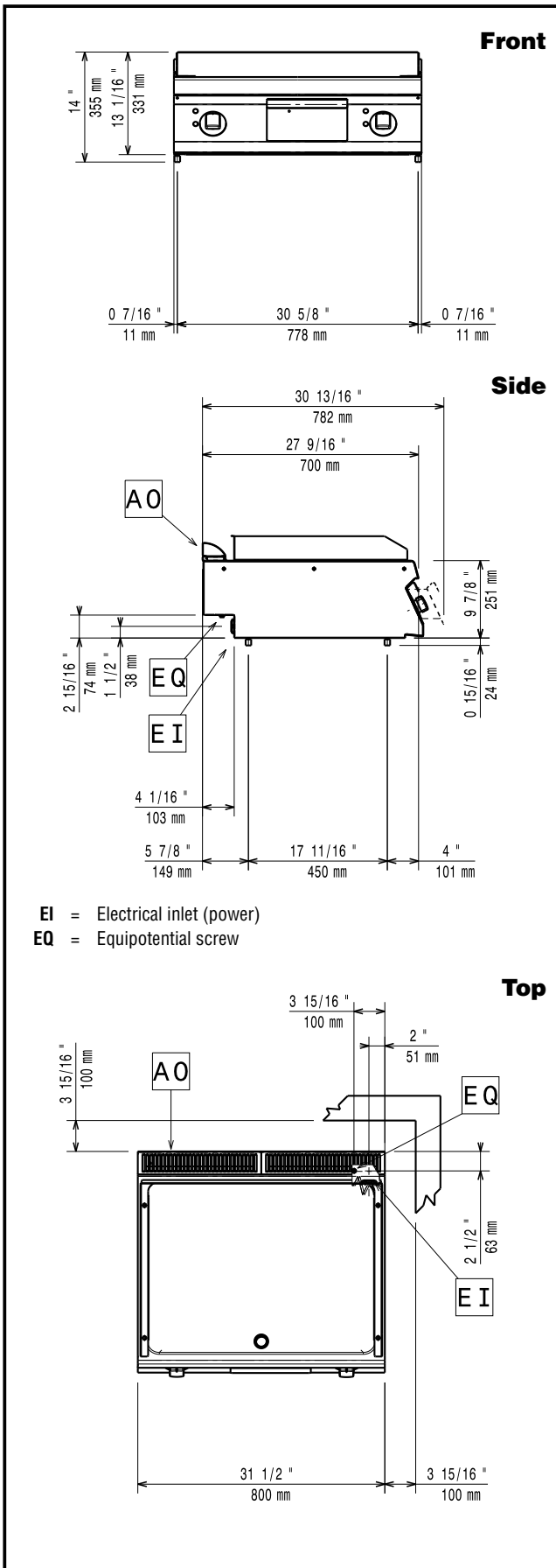

Electric

Supply voltage:

372197 (Z7FTEHCPI0)	400 V/3 ph/50/60 Hz
372201 (Z7FTEHCPIIN)	230 V/3 ph/50/60 Hz

Electrical power max.:

372197 (Z7FTEHCPI0)	8.4 kW
372201 (Z7FTEHCPIIN)	7.8 kW

Total Watts:

372197 (Z7FTEHCPI0)	8.4 kW
372201 (Z7FTEHCPIIN)	7.8 kW

Predisposed for:

380-400V 3~ 50/60Hz 7.6-8.4kW

Key Information:

Cooking surface width:	730 mm
Cooking surface depth:	540 mm
Working Temperature MIN:	120 °C
Working Temperature MAX:	280 °C
External dimensions, Width:	800 mm
External dimensions, Depth:	700 mm
External dimensions, Height:	250 mm
Net weight:	70 kg

Shipping weight:

372197 (Z7FTEHCPI0)	73 kg
372201 (Z7FTEHCPIIN)	84 kg

Shipping height:

372197 (Z7FTEHCPI0)	520 mm
372201 (Z7FTEHCPIIN)	540 mm

Shipping width:

372197 (Z7FTEHCPI0)	840 mm
372201 (Z7FTEHCPIIN)	820 mm

Shipping depth:

372197 (Z7FTEHCPI0)	860 mm
---------------------	--------

Shipping volume:

372197 (Z7FTEHCPI0)	0.38 m ³
---------------------	---------------------

If appliance is set up or next to or against temperature sensitive furniture or similar, a safety gap of approximately 150 mm should be maintained or some form of heat insulation fitted.

Certification group:

372197 (Z7FTEHCPI0)	N7RE
372201 (Z7FTEHCPIIN)	N7RE1