

TAE61P5

BAKERY COMBI / PASTRY DECK COMBINATIONS

**INDUSTRY
KITCHENS**
www.industrykitchens.com.au 1800 611 058

zanolli
1952-ITALY

Main Features

HOOD

Exhaust Hood with Optional 400 or 600 mc3
Suction capacity.

BAKING CHAMBER

- 6 Trays Capacity (600 x 400)
- Large 80mm Tray Spacing
- Self cleaning
- Weekly Auto Start Up
- 147 Baking Programs
- 2 speed fan regulation
- Bi-directional reversing fan system
- Halogen light
- Convection Cooking
- Combination Cooking
- Steam Cooking
- Probe Cooking
- Touch Panel User Control
- Automatic Preheat
- 6 Cooking Cycles for each Program
- Digital Steam Exhaust Regulation
- Water injection regulation

DECK OVENS

- 1 x Teorema Polis Pastry Deck
Ovens accommodating 2 x (600 x 400)
Tray(s)
- Stone / or steel base options
- Optional steam Boiler

PROVER

- 5 Trays Capacity (600 x 400)
- Large 75mm Tray Spacing
- Proofer with pan-holder
- Optional humidifier
- Door made of tempered glass
- Castor wheels with brakes

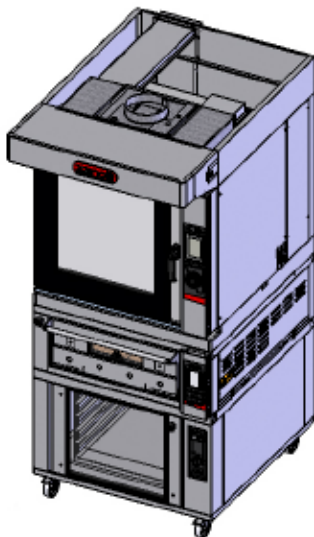

SPECIFICATIONS

Voltage	400V 3 Phase
Power	17.9 kw
Weight	360 kg
Plug Supplied	No
Capacity	6 Trays (400 x 600) for Anemos Bakery Combi 2 Trays (400 x 600) for Teorema Polis Pastry Deck Oven 5 Trays (400 x 600) for Proving Cabinet
Thermostat	260°C Teorema Anemos bakery Combi 400°C Teorema Polis Bakery Deck
Warranty	4 Year Warranty (2 yr Labour 4 yr Parts)

COMPONENTS

1 X Ventilation Hood Top	1COM019A
1 X 6 Tray Teorema Anemos 6E/MC Touch Bakery Combi Oven	5FC0403
1 X Stacking Kit	1COM006A
1 X TPOLIS 2S 2 Tray Baking Deck Oven	2P02H05B
1 X 5 Tray Prover Cabinet with Humidifier	1COM008A

DIMENTIONS

External Width	970mm
External Depth	1351mm (including hood)
External Height	2211mm



Phone: 1800 183 818 Email: support@thegoodlady.com.au
Website: www.thegoodlady.com.au

TAE61P5

EXHAUST HOOD STRUCTURE AND PROVISION

FRONT

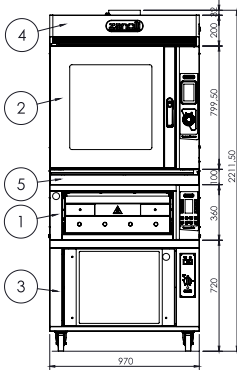

Item num.	Quantity	Description	Power	Trays	Distance (between trays)
1	1	PROVING CABINET	6.4KW	70"	75mm
2	1	TRANSFORMER (DISH)	10.4KW	70"	80mm
3	1	PROVING CABINET	1KW	70"	75mm
4	1	EXHAUST HOOD	0.3KW		
5	1	DECK OVEN			
Optional		Power			
HUMIDIFIER FOR PROVING CABINET		1KW			
STEAM BOILER FOR DECK OVEN		2.8KW			

SIDE

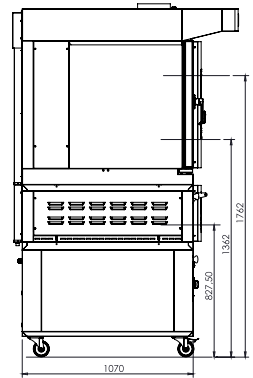
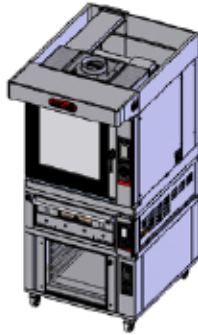

REAR

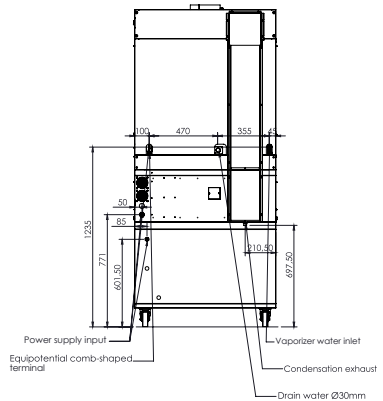
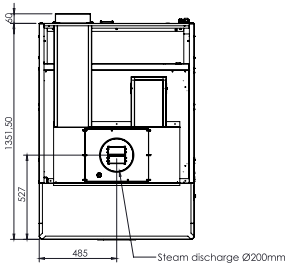

We reserve the right to alter specifications without notice.



Phone: 1800 183 818 Email: support@thegoodlady.com.au
 Website: www.thegoodlady.com.au

TAE61P5

EXHAUST HOOD STRUCTURE, PROVISION & MOTOR (400M3/600M3 CAPACITY)

FRONT

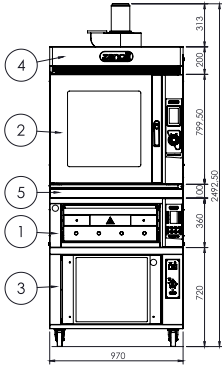

Item num.	Quantity	Description	Power	Trays	Distance between trays
1	1	PROVISION	6.4 KW	12"	
2	1	EXHAUST HOOD	10.5 KW	12"	50mm
3	1	PROOFING CABINET	1 KW	11"	75mm
4	1	EXHAUST HOOD WITH MOTOR KIT COMPLETE	0.25 KW		

Optional	Power
HUMIDIFIER FOR PROOFING CABINET	1KW
STEAM BOILER FOR DECK OVEN	2.8KW

SIDE

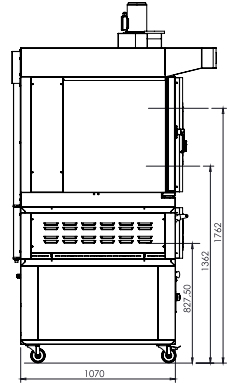

REAR

TOP

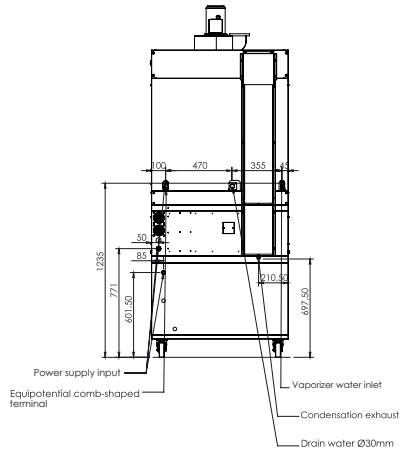
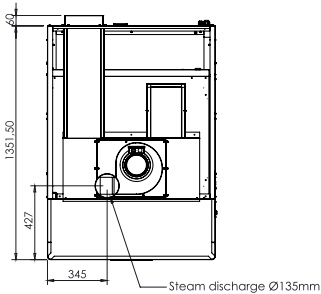

We reserve the right to alter specifications without notice.



Phone: 1800 183 818 Email: support@thegoodlady.com.au
Website: www.thegoodlady.com.au

TAE61P5

NO EXHAUST PROVISION

FRONT

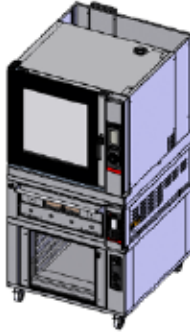
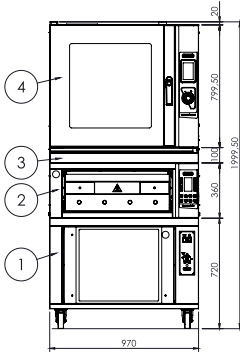

SIDE

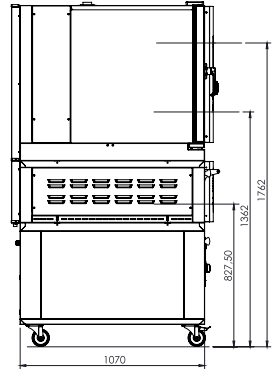

Item num.	Quantity	Description	Power	Trays	Distance (between trays)
1	1	PROOFING CABINET	1 kW	n°10	75mm
2	1	T POCUS 25	6.4 kW	n°2	
3	1	KIT COMBI			
4	1	T ANEMOS 6E TOUCH	10.5 kW	n°6	80mm
Optional		Power			
		HUMIDIFIER FOR PROOFING CABINET	1 KW		
		STEAM BOILER FOR DECK OVEN	2.8KW		

REAR

TOP

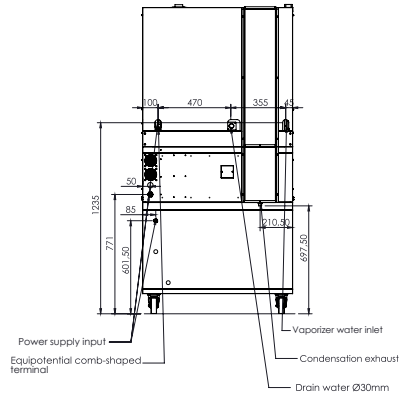
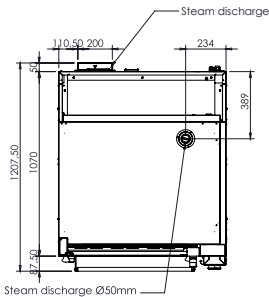

We reserve the right to alter specifications without notice.



Phone: 1800 183 818 Email: support@thegoodlady.com.au
 Website: www.thegoodlady.com.au