

TAE101P3

BAKERY COMBI / PASTRY DECK COMBINATIONS

INDUSTRY
KITCHENS
www.industrykitchens.com.au 1800 611 058

zanolli
1952-ITALY

Main Features

HOOD

Exhaust Hood with Optional 400 or 600 mc3
Suction capacity.

BAKING CHAMBER

- 10 Trays Capacity (600 x 400)
- Large 80mm Tray Spacing
- Self cleaning
- Weekly Auto Start Up
- 147 Baking Programs
- 2 speed fan regulation
- Bi-directional reversing fan system
- Halogen light
- Convection Cooking
- Combination Cooking
- Steam Cooking
- Probe Cooking
- Touch Panel User Control
- Automatic Preheat
- 6 Cooking Cycles for each Program
- Digital Steam Exhaust Regulation
- Water injection regulation

DECK OVENS

- 1 x Teorema Polis Pastry Deck Ovens accommodating 2 x (600 x 400) Trays
- Stone / or steel base options
- Optional steam Boiler

PROOVER

- 3 Trays Capacity (600 x 400)
- Large 75mm Tray Spacing
- Proofer with pan-holder
- Optional humidifier
- Door made of tempered glass
- Castor wheels with brakes

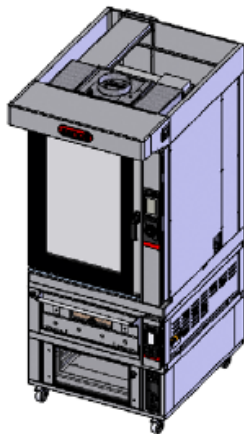

SPECIFICATIONS

Voltage	400V 3 Phase
Power	23.1 kw
Weight	385 kg
Plug Supplied	No
Capacity	10 Trays (400 x 600) for Anemos Bakery Combi 2 Trays (400 x 600) for Teorema Polis Pastry Deck Oven 3 Trays (400 x 600) for Proving Cabinet
Thermostat	260°C Teorema Anemos bakery Combi 400°C Teorema Polis Bakery Deck
Warranty	4 Year Warranty (2 yr Labour 4 yr Parts)

COMPONENTS

1 x Ventilation Hood Top	1COM019A
1 x 10 Tray TEOREMA Anemos 10E/MC TOUCH Bakery Combi Oven	5FC0503
1 x Stacking kit	1COM010A
1 x TPOLIS 2S 2 tray Bakery Deck Oven	2P02H05B
1 x 3 Tray Proving Cabinet with Humidifier on Castors	1COM009A

DIMENTIONS

External Width	970mm
External Depth	2347mm (including hood)
External Height	1351mm



Phone: 1800 183 818 Email: support@thegoodlady.com.au
Website: www.thegoodlady.com.au

TAE101P3

EXHAUST HOOD STRUCTURE AND PROVISION

FRONT

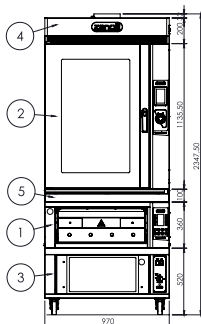

Item num.	Quantity	Description	Power	Trays	Distance between trays
1	1	VIT COOKER	4.4 KW	n/a	
2	1	TANIZAKI DE TOUCH	19.7 KW	n/a	80mm
3	1	PROOFING CABINET	1 KW	n/a	75mm
4	1	EXHAUST HOOD	0.3 KW		

Optional	Power
HUMIDIFIER FOR PROVING CABINET	1KW
STEAM BOILER FOR DECK OVEN	2.8KW

SIDE

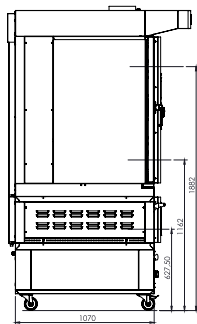
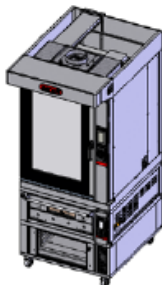

REAR

TOP

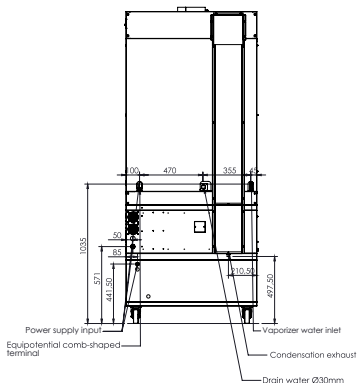
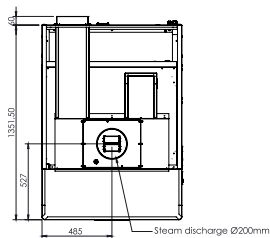

We reserve the right to alter specifications without notice.

TAE101P3

EXHAUST HOOD STRUCTURE, PROVISION & MOTOR (400M3/600M3 CAPACITY)

FRONT

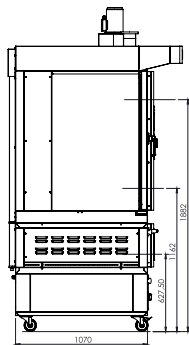
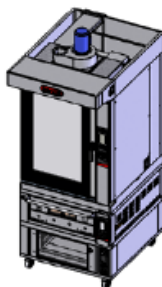
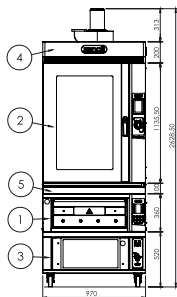

Item num.	Quantity	Description	Power	Trays	Distance between trays
1		FILTER 25	6.4 KW	n/2	
2		LANEMAS 10E 1000-H	15.7 KW	n/10	86mm
3	1	PROOFING CABINET	1 kW	n/6	75mm
4		STEAM BOILER FOR DECK OVEN	0.25 KW		

Optional	Power
HUMIDIFIER FOR PROVING CABINET	1 KW
STEAM BOILER FOR DECK OVEN	2.8KW

SIDE

REAR

TOP

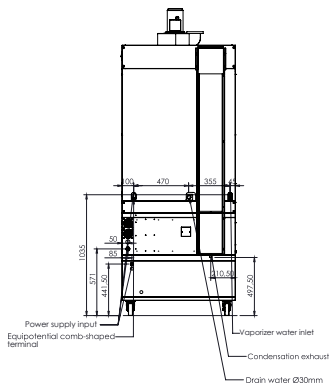
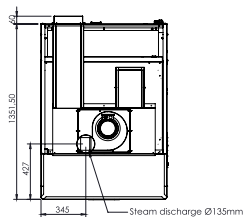

We reserve the right to alter specifications without notice.

TAE101P3

NO EXHAUST PROVISION

FRONT

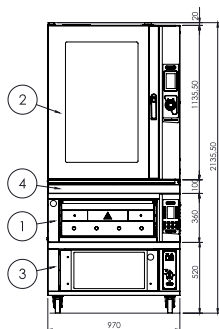

Item num.	Quantity	Description	Power	Trays	Distance between trays
1	1	T POLIS 2S	6.4 kW	n°2	
2	1	T ANEMOS 10E TOUCH	15.7 kW	n°10	80mm
3	1	PROOFING CABINET	1 kW	n°6	75mm
4	1	KIT COMBI			

Optional	Power
HUMIDIFIER FOR PROVING CABINET	1KW
STEAM BOILER FOR DECK OVEN	2.8KW

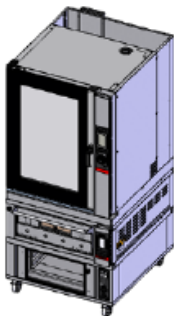

SIDE

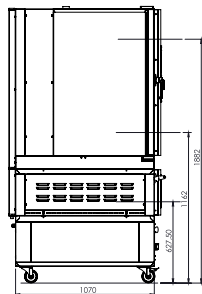

REAR

TOP

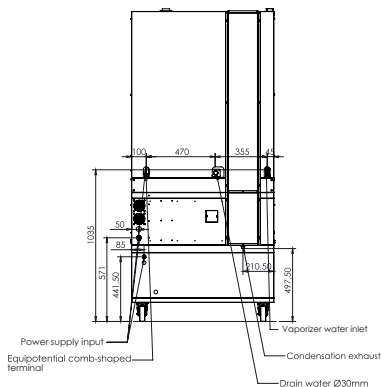
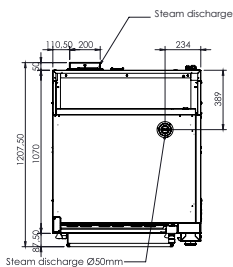

We reserve the right to alter specifications without notice.