

NOTE: Filter Angles and Gutters in compliance with latest A.S 1668.2-2024

NOTE: GFE Australia is not qualified to determine the application of AS1668:2024, and particularly the parent building codes and standards that reference it, as they may pertain to the unique and specialist Food Vans and "Container Kitchens" that are transportable. GFE Australia therefore, is not in a position to offer or issue a statement of compliance for these canopies in these applications. GFE Australia can confirm that all materials employed are impervious, hard-faced and deemed non-combustible, and that the design Filter angle is in compliance with the latest AS1668 requirements, and that the VanAir canopies also have integral gutters on all four sides, again compliant with that section of the standard. It is the responsibility of the purchaser/user to seek suitable expert opinion to validate compliance for their particular application.

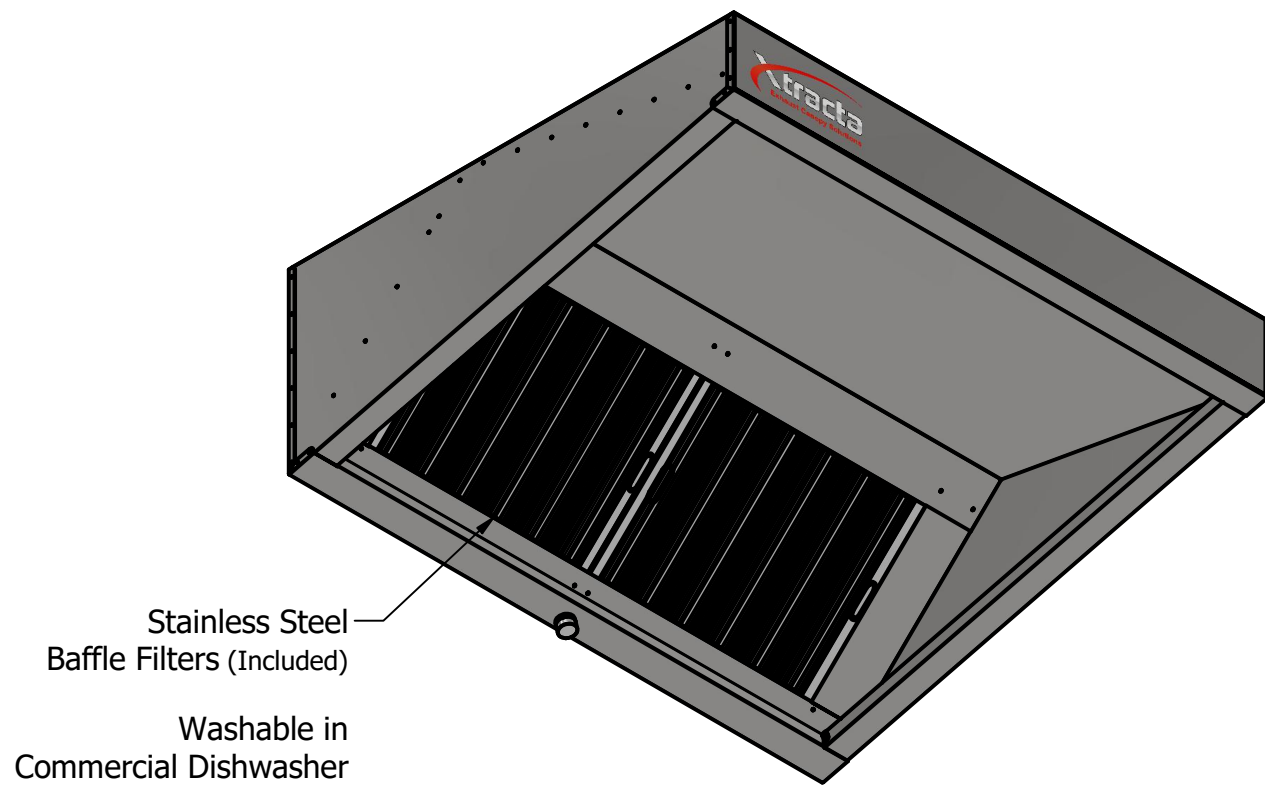
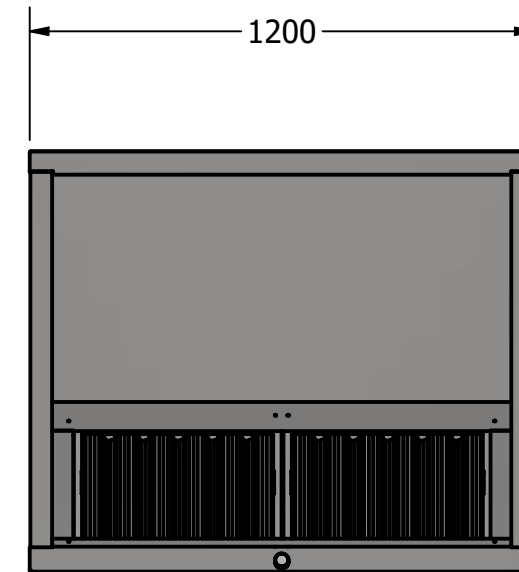
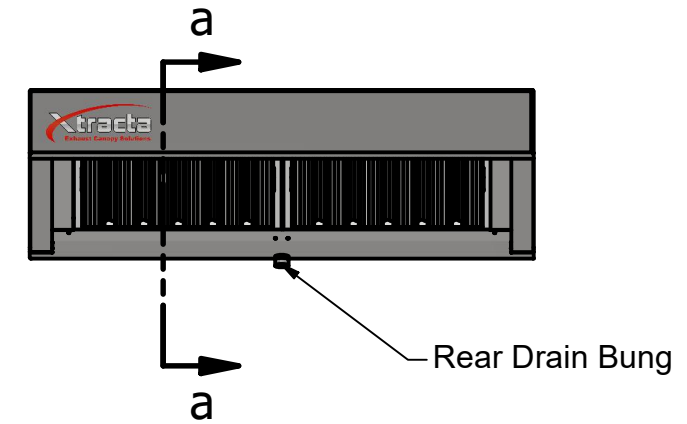
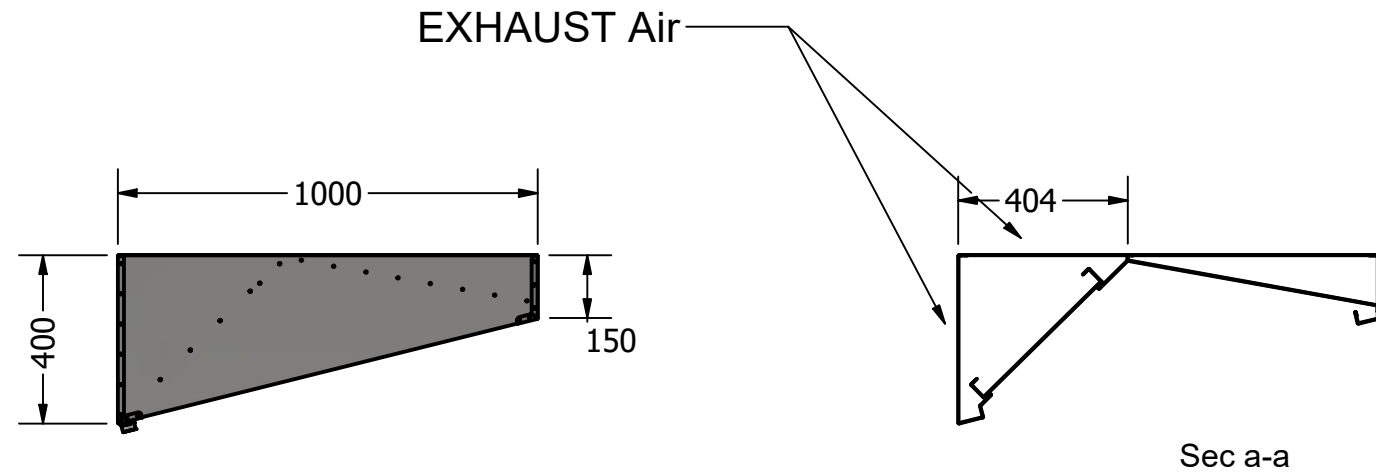

Approximate Canopy Weight - 32 kg

NOTE. Xtracta Food Van models do not have provision for integrated return air handling. Return air must be provided by other means into the facility as required.



PROJECT				
Xtracta VanAir				
DWG NO				
VanAir - 12_10 - 400				
SIZE	SCALE	SHEET	DATE	REV
A3	DNS	1	27/05/2026	3