

Model  
**CHEFLUX™**

- Convection oven
- Electric
- 20 trays GN 1/1
- Hinged left (right hand door)
- Control knob



## DESCRIPTION

Dry air-steam combi oven with analogical control and 304 stainless steel cooking chamber. Time, temperature, steam percentage and 2 fan speeds function. Allows to perform traditional cooking processes such as steaming, browning, grilling, frying and cooking of fresh and frozen bakery products.

## STANDARD COOKING FEATURES

Manual cooking

- **Temperature:** 80 °C – 260 °C
- Convection and humidity cooking starting from 80 °C

## STANDARD TECHNICAL FEATURES

- Cooking chamber in high-resistance AISI 304 stainless steel with rounded edges
- Double glass
- Cooking chamber lighting through LED lights embedded in the door
- Tray supports with anti-tipping system
- 2-speed fan system and high-performance circular resistance

## ADVANCED AND AUTOMATIC COOKING FEATURES

Unox Intensive Cooking

- **DRY.Plus:** extracts humidity from the cooking chamber
- **STEAM.Plus:** creates instant humidity starting from 48 °C
- **AIR.Plus:** multiple fans with reverse gear and 2 speed settings

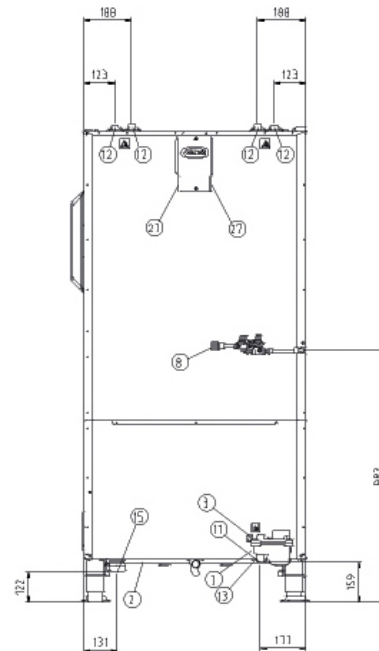
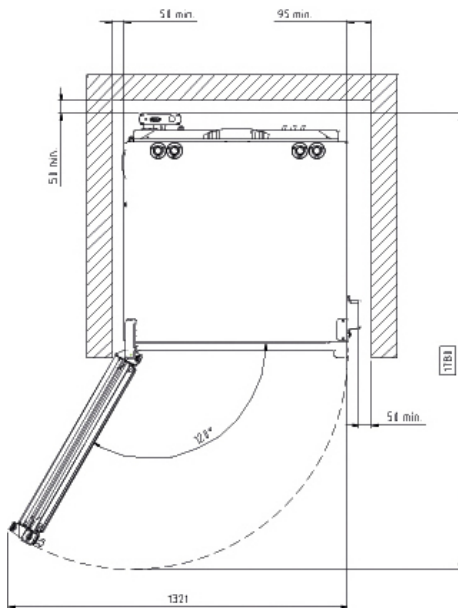
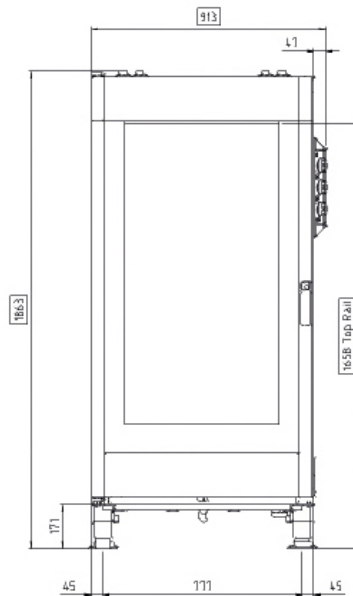
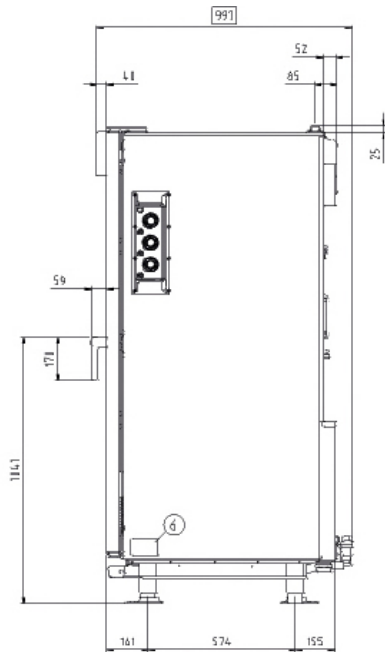

## DIMENSIONS AND WEIGHT

Width	913 mm
Depth	997 mm
Height	1863 mm
Net Weight	240 kg
Pan spacing	66 mm

## CONNECTION POSITIONS

2 Terminal board power supply	11 Cavity drain pipe
3 Unipotential terminal	12 Hot fumes exhaust chimney
6 Technical data plate	13 Accessories connection
7 Safety thermostat	15 Cable press
8 3/4" Thread water inlet	22 Water pump inlet

## XV1093

### POWER AND GAS SUPPLY

#### STANDARD

Voltage	380-415 V
Phase	~3PH+N+PE
Frequency	50 / 60 Hz
Total power	29.7 kW
Maximum Amp Draw	44 A
Required breaker size	50 A
Power cable requirement	H07RN-F 5G 5G
Cord diameter	38 mm
Plug	NOT INCLUDED

#### OPTION A

Voltage	220-240 V
Phase	~3PH+PE
Frequency	50 / 60 Hz
Total power	29.7 kW
Maximum Amp Draw	74 A
Required breaker size	80 A
Power cable requirement	H07RN-F 4G 4G
Cord diameter	38 mm
Plug	NOT INCLUDED

### ACCESSORIES

- **Cooking Essentials:** special trays
- **QUICK.Load**
- **SPRAY&Rinse:** Practical spray detergent to manually clean all kinds of oven. Degreases and removes all kind of dirt
- **PURE-RO:** reverse osmosis system that eliminates Chlorides and limescale from water
- **PURE:** the filter reduces the carbonate hardness in water, thus avoiding scale deposits inside the oven cooking chamber

### INSTALLATION REQUIREMENTS

Installations must comply with all local electrical systems, particularly as for minimum wire gauge required for field connection, hydraulic and ventilation supply. Exhaust and fume analysis must be performed in case of gas ovens.

Register to access data and product specifications  
[infonet.unox.com](http://infonet.unox.com)

