

Model  
**LINEMICRO™**

- Convection oven
- Electric
- 4 trays 600x400
- Drop-down door opening
- Control knob

## DESCRIPTION

Combi oven with analogical control and stainless steel cooking chamber. It allows to set the cooking time and temperature. Ideal for frozen bakery and pastry products for breakfast and fast foods. The AIR.Plus technology guarantees perfect cooking uniformity on all baking trays.



## STANDARD COOKING FEATURES

Manual cooking - linemicro

- **Temperature:** 80 °C – 260 °C

## STANDARD TECHNICAL FEATURES

- Rounded baking chamber made of high resistant ferritic steel for hygiene and ease of cleaning
- Double glass
- Oven chamber lighting with halogen lamp
- Baking chamber with chrome-plated steel rack rails

## ADVANCED AND AUTOMATIC COOKING FEATURES

Unox Intensive Cooking - linemicro 600x400

- **DRY.Plus:** extracts humidity from the cooking chamber
- **AIR.Plus:** multiple fans with reverse gear and 2 speed settings

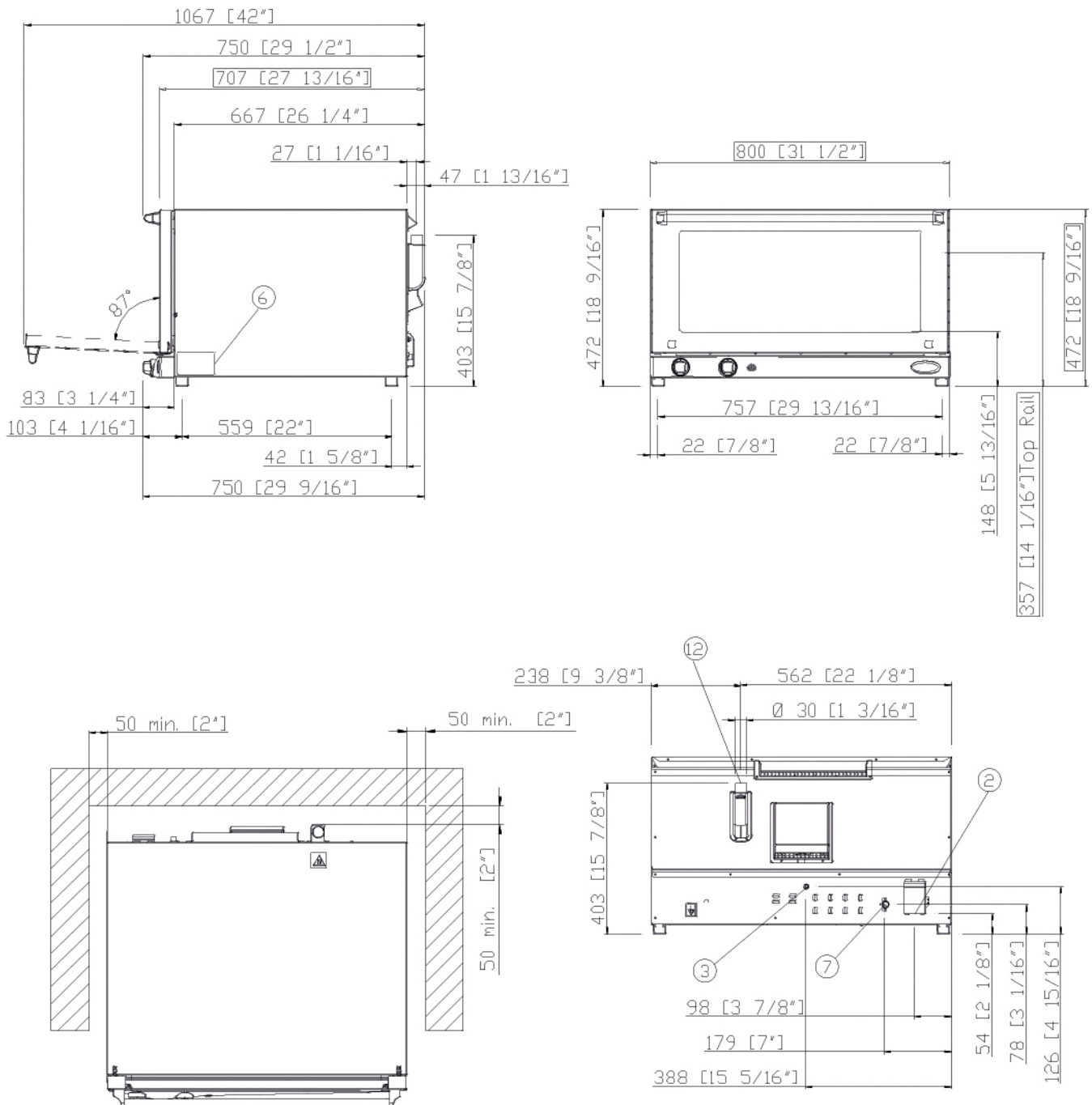

## DIMENSIONS AND WEIGHT

Width	800 mm
Depth	706 mm
Height	472 mm
Net Weight	44 kg
Pan spacing	70 mm

## CONNECTION POSITIONS

2	Terminal board power supply
3	Unipotential terminal
6	Technical data plate
7	Safety thermostat
12	Hot fumes exhaust chimney



# XF043

# INDUSTRY KITCHENS

www.industrykitchens.com.au 1800 611 058

Power and gas supply

Water connections

Installation requirements

Accessories

## POWER AND GAS SUPPLY

### STANDARD

Voltage	380-415 V
Phase	~3PH+N+PE
Frequency	50 Hz
Total power	5,3 kW
Maximum Amp Draw	13 A
Required breaker size	16 A
Power cable requirement	H07RN-F 5G 5G
Cord diameter	16 mm
Plug	NOT INCLUDED

### OPTION A

Voltage	220-240 V
Phase	~3PH+PE
Frequency	50 Hz
Total power	5,3 kW
Maximum Amp Draw	13 A
Required breaker size	16 A
Power cable requirement	H07RN-F 4G 4G
Cord diameter	16 mm
Plug	NOT INCLUDED

### OPTION B

Voltage	220-240 V
Phase	~1PH+PE
Frequency	50 Hz
Total power	5,3 kW
Maximum Amp Draw	23 A
Required breaker size	25 A
Power cable requirement	H07RN-F 3G 3G
Cord diameter	16 mm
Plug	NOT INCLUDED

## ACCESSORIES

- **Baking Essentials:** special trays
- **SPRAY&Rinse:** Practical spray detergent to manually clean all kinds of oven. Degreases and removes all kind of dirt

## INSTALLATION REQUIREMENTS

Installations must comply with all local electrical systems, particularly as for minimum wire gauge required for field connection, hydraulic and ventilation supply. Exhaust and fume analysis must be performed in case of gas ovens.

Register to access data and product specifications  
[infonet.unox.com](http://infonet.unox.com)

