

CATEGORY GENERAL UPRIGHTS

RANGE **Pearl**

UNIT FREEZER SELF

TYPE CONTAINED 3

DOORS

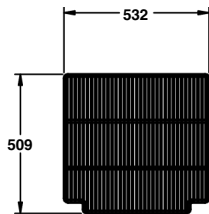

SHELF DETAIL

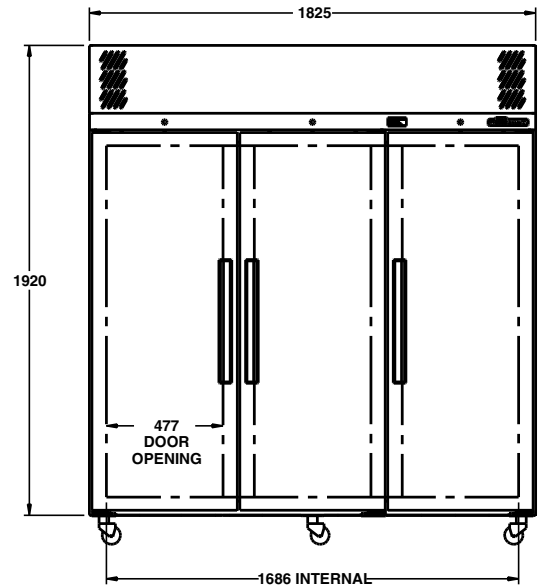
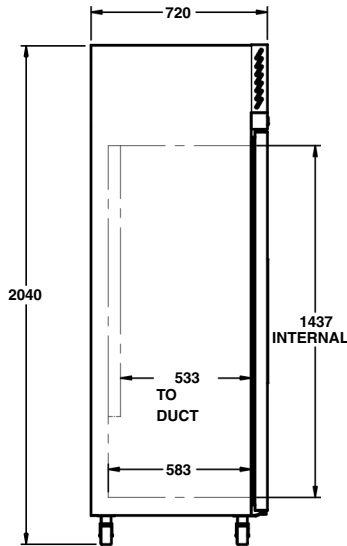
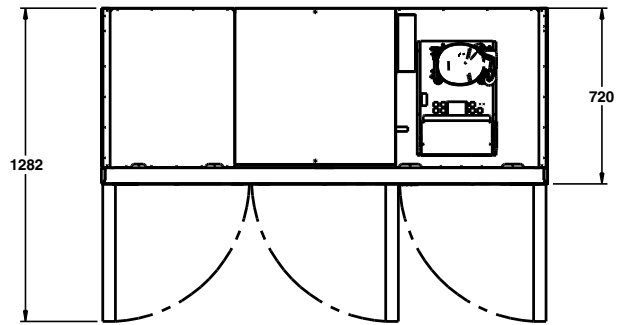

SPECIFICATIONS

| | |
|---|-------------------------|
| CAPACITY LITRES | 1510 |
| TEMPERATURE | -18°C / -22°C |
| DIMENSIONS - W X D X H (ON 120 MM H CASTORS) MM | 1825 W x 720 D x 2040 H |
| WEIGHT UNPACKED (KG) | 290 |

STANDARD INCLUSIONS ***

| | |
|---|---------------------|
| DOOR TYPE | S (Solid Door) |
| FINISH (INTERIOR AND EXTERIOR EXCLUDING REAR AND UNDER) | S (Stainless Steel) |
| SHELVES/DOOR (ADJUSTABLE STRIPS AND CLIPS) | 4 |

GAS TYPE

| | |
|-------------|------|
| REFRIGERANT | R290 |
|-------------|------|

ELECTRICAL

| | |
|-----------------------------|--------|
| POWER SUPPLY | 10 amp |
| POWER CABLE LENGTH (METRES) | 2 |
| RUNNING AMPS | EDÉ |

PERFORMANCE

| | |
|------------------|-------------------------|
| KWH/24HR READING | EEDFÉ |
| TEST STANDARD | EN 16825 (Professional) |
| TEST CONDITIONS | 4 L1 |
| AMBIENT RATING | ED°C |

REFRIGERATION WATTAGES FOR OPTIONAL REMOTE UNITS

| | |
|--------------------------------------|------------------|
| FREEZER MODELS - SOLID DOORS (R448a) | 1550 @ -30°C SST |
|--------------------------------------|------------------|

*** For **OPTIONS** refer to the current Williams Price Guide