

# LA135SS-HC

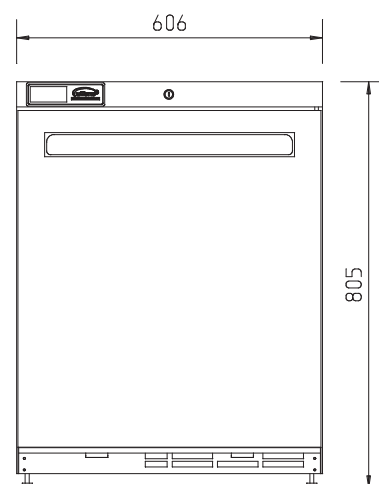

CATEGORY	HYDROCARBON
RANGE	<b>Amber</b>
UNIT	FREEZER
TYPE	SELF CONTAINED
DOORS	1

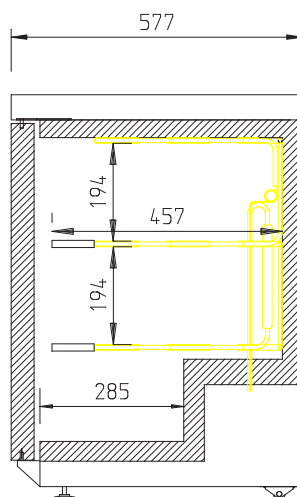
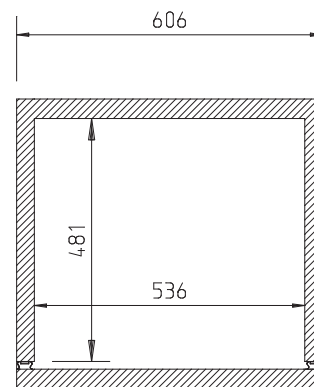

## SPECIFICATIONS

CAPACITY LITRES	135
TEMPERATURE	-18°C / -22°C
DIMENSIONS - W X D X H (ON CASTORS) MM	606 W x 577 D x 805 H
WEIGHT UNPACKED (KG)	65

## STANDARD INCLUSIONS \*\*\*

DOOR TYPE	Standard: SD (Solid Door)
FINISH (INTERIOR AND EXTERIOR EXCLUDING REAR AND UNDER)	SS (Stainless Steel)
SHELVES	2 Fixed

## ELECTRICAL

POWER SUPPLY	10 amp
POWER CABLE LENGTH (METRES)	2
RUNNING AMPS	1.3

## GAS TYPE

REFRIGERANT	R290
-------------	------