

# HPR2GSHC

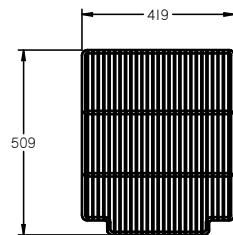

CATEGORY	GENERAL UPRIGHTS
RANGE	<b>Pearl</b>
UNIT	REFRIGERATOR
TYPE	SELF CONTAINED
DOORS	2

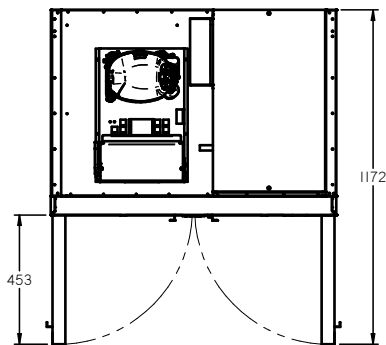

SHELF DETAIL

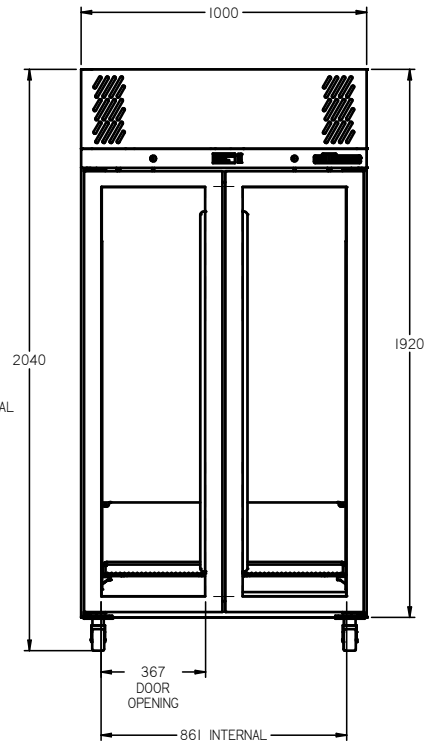
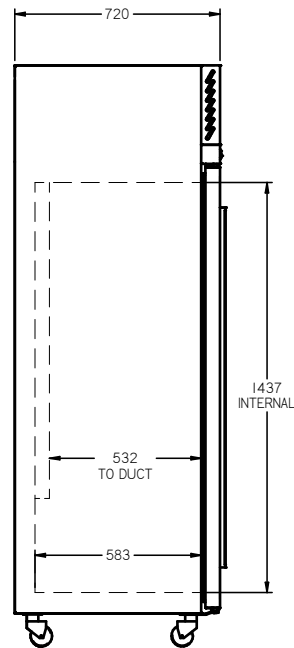

## SPECIFICATIONS

CAPACITY LITRES	750
TEMPERATURE	1°C / 4°C
DIMENSIONS - W X D X H (ON 120 MM H CASTORS) MM	1000 W x 720 D x 2040 H
WEIGHT UNPACKED (KG)	200

## STANDARD INCLUSIONS \*\*\*

DOOR TYPE	G (Glass Door), Optional: PT (Pass Through)
FINISH (INTERIOR AND EXTERIOR EXCLUDING REAR AND UNDER)	S (Stainless Steel)
SHELVES/DOOR (ADJUSTABLE STRIPS AND CLIPS)	4

## GAS TYPE

REFRIGERANT	R290
-------------	------

## ELECTRICAL

POWER SUPPLY	10 amp
POWER CABLE LENGTH (METRES)	2
RUNNING AMPS	1.1

## PERFORMANCE

KWH/24HR READING	2.94
TEST STANDARD	ISO 23953 (Display)

## TEST CONDITIONS

AMBIENT RATING	40°C
----------------	------

## REFRIGERATION WATTAGES FOR OPTIONAL REMOTE UNITS

FRIDGE MODELS - GLASS DOORS (R448a)	760 @ -5°C SST
-------------------------------------	----------------

\*\*\* For **OPTIONS** refer to the current Williams Price Guide