

CATEGORY GENERAL UPRIGHTS

RANGE **Pearl**

UNIT REFRIGERATOR

TYPE SELF CONTAINED

DOORS 2

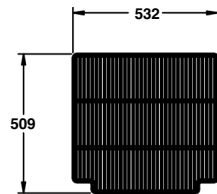

SHELF DETAIL

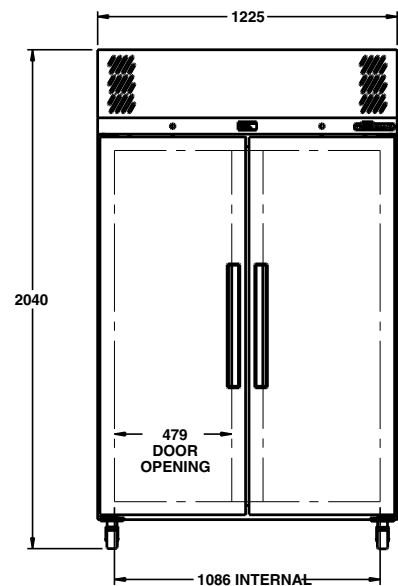
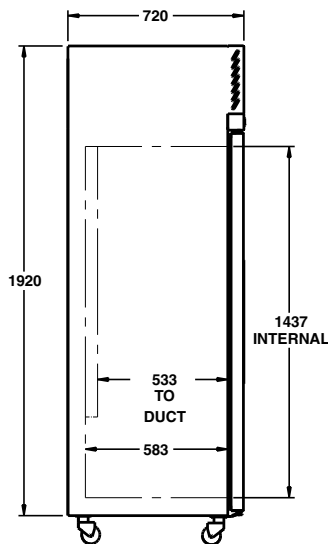
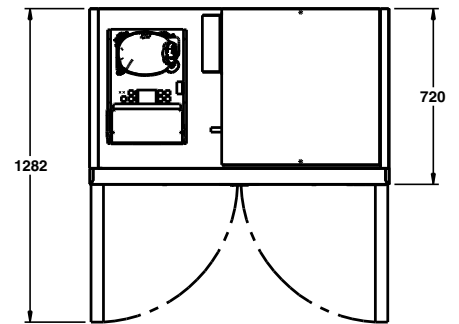

### SPECIFICATIONS

CAPACITY LITRES	950
TEMPERATURE	1°C / 4°C
DIMENSIONS - W X D X H (ON 120 MM H CASTORS) MM	1225 W x 720 D x 2040 H
WEIGHT UNPACKED (KG)	220

### STANDARD INCLUSIONS \*\*\*

DOOR TYPE	S (Solid Door), Optional: PT (Pass Through)
FINISH (INTERIOR AND EXTERIOR EXCLUDING REAR AND UNDER)	S (Stainless Steel)
SHELVES/DOOR (ADJUSTABLE STRIPS AND CLIPS)	4

### GAS TYPE

REFRIGERANT	R290
-------------	------

### ELECTRICAL

POWER SUPPLY	10 amp
POWER CABLE LENGTH (METRES)	2
RUNNING AMPS	ÊÐÊ

### PERFORMANCE

KWH/24HR READING	ÊÐÊ
TEST STANDARD	EN 16825 (Professional)
TEST CONDITIONS	4 M1
AMBIENT RATING	ÊÐ°C

### REFRIGERATION WATTAGES FOR OPTIONAL REMOTE UNITS

FRIDGE MODELS - SOLID DOORS (R448a)	580 @ -5°C SST
-------------------------------------	----------------

\*\*\* For **OPTIONS** refer to the current Williams Price Guide