

# HB1UGS

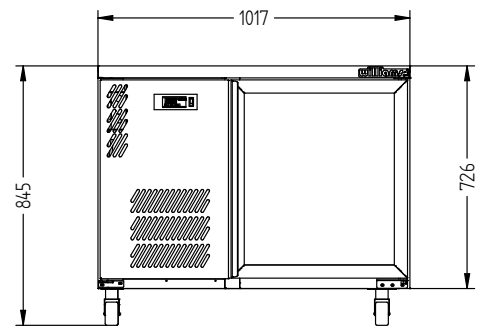

CATEGORY	GENERAL COUNTERS & BACK BARS
RANGE	<b>BORONIA</b>
UNIT	REFRIGERATOR
TYPE	SELF CONTAINED
DOORS	1

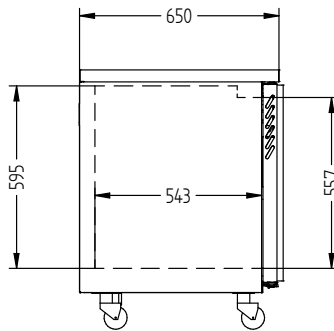
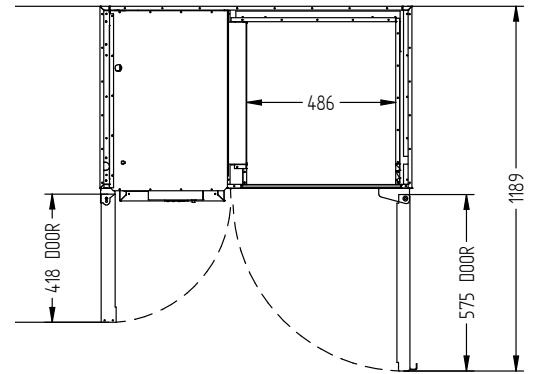

## SPECIFICATIONS

CAPACITY LITRES	180
TEMPERATURE	1°C / 4°C
FRONT BREATHING	YES
DIMENSIONS - W X D X H (ON CASTORS) MM	1017 W x 650 D x 845 H
WEIGHT UNPACKED (KG)	110

## STANDARD INCLUSIONS \*\*\*

DOOR TYPE	Standard: G (Glass Door)
FINISH	S (Stainless Steel) interior and exterior excluding rear and under
SHELVES/DOOR	2

## ELECTRICAL

POWER SUPPLY	10 amp	
FRIDGE MODELS	RUNNING AMPS	2.1

## GAS TYPE

REFRIGERANT	FRIDGE MODELS	R134a
-------------	---------------	-------

\*\*\* For **OPTIONS** refer to the current Williams Price Guide