

GC25RGD



CATEGORY GENERAL COUNTERS & BACK BARS

RANGE **Glass Chiller**

UNIT REFRIGERATOR

TYPE REMOTE

DOORS 2

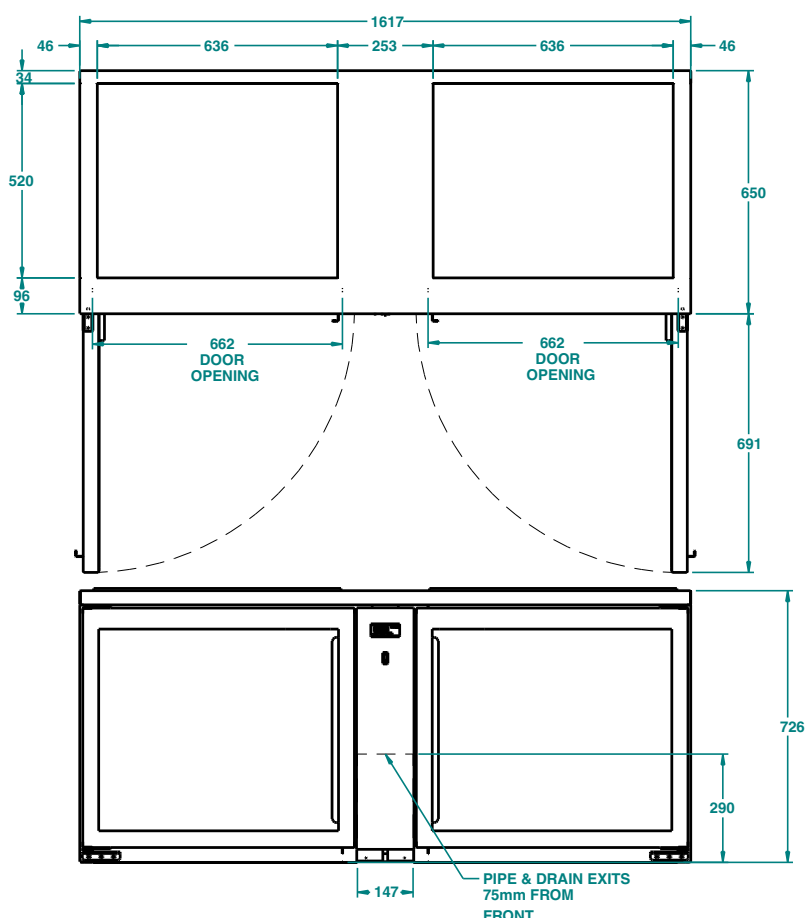
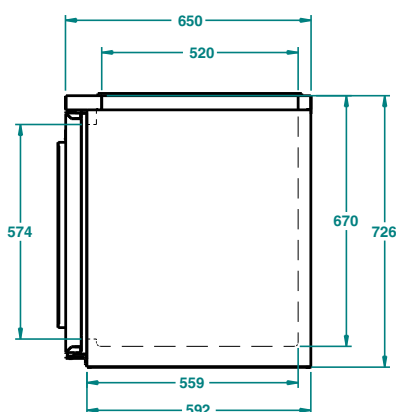

SPECIFICATIONS

CAPACITY - BASKETS/DOOR (NOT INCLUDED)(500 X 500 BASKET) (BASED ON 150MM H GLASSES)

3 Baskets

TEMPERATURE

1°C / 4°C

SHELF LOAD

YES

DIMENSIONS - W X D X H (ON 150MM H LEGS) MM

1617 W x 649 D x 875 H

WEIGHT UNPACKED (KG)

100

STANDARD INCLUSIONS ***

DOOR TYPE

Standard: GD (Glass Door)

FINISH (INTERIOR AND EXTERIOR EXCLUDING REAR AND UNDER)

SS (Stainless Steel)

SHELVES/DOOR - SHELF LOAD MODEL ONLY

2

ELECTRICAL

POWER SUPPLY

10 amp

POWER CABLE LENGTH (METRES)

2

RUNNING AMPS

0.5

GAS TYPE

REFRIGERANT

R448a

REFRIGERATION WATTAGES FOR REMOTE UNITS

REMOTE WATTAGES

750 @ -5° C SST

*** For **OPTIONS** refer to the current Williams Price Guide