

GC15RGD

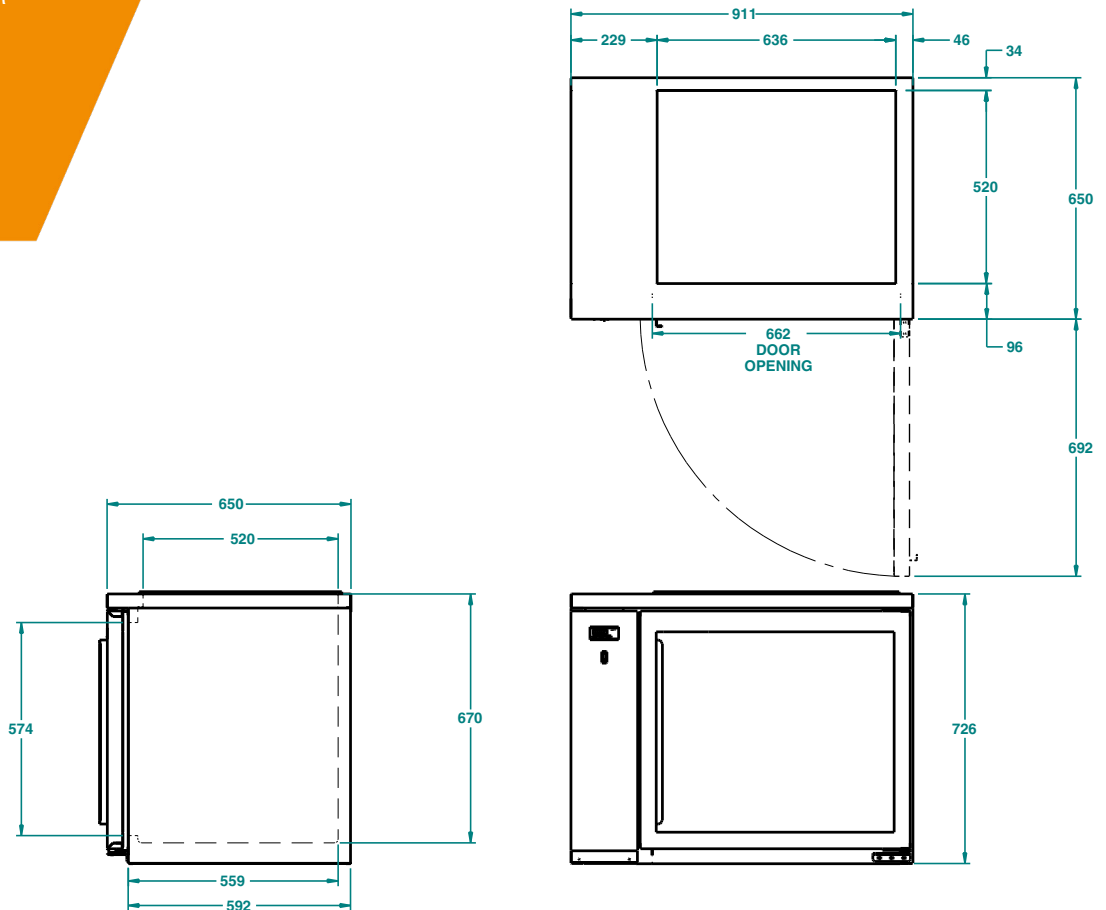

CATEGORY	GENERAL COUNTERS & BACK BARS
RANGE	Glass Chiller
UNIT	REFRIGERATOR
TYPE	REMOTE
DOORS	1



SPECIFICATIONS

CAPACITY - BASKETS/DOOR (NOT INCLUDED)(500 X 500 BASKET) (BASED ON 150MM H GLASSES)	3 Baskets
TEMPERATURE	1°C / 4°C YES 911 W x
SHELF LOAD	649 D x 875 H 60
DIMENSIONS - W X D X H (ON 150MM H LEGS) MM	
WEIGHT UNPACKED (KG)	
STANDARD INCLUSIONS ***	
DOOR TYPE FINISH (INTERIOR AND EXTERIOR EXCLUDING REAR AND UNDER) SHELVES/DOOR - SHELF LOAD MODEL ONLY	Standard: GD (Glass Door) SS (Stainless Steel) 2

ELECTRICAL

POWER SUPPLY POWER CABLE	10 amp
LENGTH (METRES) RUNNING	2
AMPS	0.4

GAS TYPE

REFRIGERANT	R448a
-------------	-------

REFRIGERATION WATTAGES FOR REMOTE UNITS

REMOTE WATTAGES 570 @ -5° C SST	
---------------------------------	--

*** For **OPTIONS** refer to the current Williams Price Guide