

Technical data sheet for

ELECTRIC COOKTOPS 600mm

RN8400E-B, RN8400E-CB, RN8400E-LS, RN8403E-B, RN8403E-CB, RN8403E-LS, RN8406E-B, RN8406E-CB, RN8406E-LS



RN8400E-B

- Heavy-duty construction
- 2.4kW open radiant elements
- Optional Hot Plate elements
- 300mm and 600mm griddle plate options
- 3 models of base unit
- Stainless steel exterior
- Easy clean
- Easy service
- Fully modular
- Low back models (RNL) available

Overall Construction

COOKTOP

- Welded hob with 1.5mm 304 stainless steel bull nose
- Splashback and side panels 1.2mm 304 stainless steel
- Front panels 0.9mm 304 stainless steel
- 2.4kW open radiant elements in heavy-duty welded element frames
- Vitreous enamelled element module and hob spill trays
- Hot Plate elements with machine finished 8mm steel plate (optional extra)
- 12mm thick mild steel griddle plates
- 2.5mm 304 stainless steel griddle splash guards
- Aluminised steel internal construction

BENCH MOUNT (SUPPLIED AS -B MODEL)

- Four 63mm dia. heavy-duty 1.2mm 304 stainless steel bench legs with adjustable feet
- Adjustable height 80mm – 105mm

CABINET BASE (SUPPLIED AS -CB MODEL)

- Fully modular for match suite finish
- Double skin 0.9mm 304 stainless steel interior and exterior
- Optional GN 1/1 4 position racking kit
- 63mm dia. heavy-duty 1.2mm 304 stainless steel legs with adjustable feet

LEG STAND (SUPPLIED AS -LS MODEL)

- Fully modular for matched suite finish
- Framed top for connection to Cooktop
- 63mm dia. heavy-duty 1.2mm 304 stainless steel legs with adjustable feet
- Fully modular framed stand shelf with 0.9mm 304 stainless steel finish
- Quick assembly design (no tools required)

Controls

- Large easy use control knob - heat resistant reinforced
- Easy view control settings on knob
- Radiant elements with energy regulator controls
- Hot Plate elements with energy regulator controls
- 50-320°C thermostat per 300mm griddle section
- Indicator lights for power and heating for each element control

Cleaning and Servicing

- All models with easy clean stainless steel external finish
- Removable vitreous enamelled element module and hob spill trays
- Hinge up element and griddle sections
- Access to all parts from front of unit

Technical data sheet for
ELECTRIC COOKTOPS 600mm



Specifications

COOKTOP

- 2.4 kW Open Radiant elements
- 2.0 kW Hot Plate elements
- 3.6 kW Griddle elements (per 300mm griddle section)

GRIDDLE PLATE

- 300mm Griddle cooking surface
- 292mm x 475mm, 1387cm²
- 600mm Griddle cooking surface
- 592mm x 475mm, 2812cm²

Electrical requirements

- RN8400E
- 9.6 kW, 400-415Vac, 50/60hz, 2P+N+E, 20A/phase
- RN8403E
- 8.4 kW, 400-415Vac, 50/60hz, 2P+N+E, 20A/phase max.
- RN8406E
- 7.2 kW, 230-240Vac, 50/60hz, 1P+N+E, 30A

Electrical connection

- 130mm from RH side, 31mm from rear
- 85mm from bench height on bench models
- 740mm from floor on leg stand and cabinet base models

DIMENSIONS

Bench models

- Width 600mm
- Depth 805mm
- Height 315mm
- Incl. splashback 530mm
- Incl. low back 370mm

All models (excluding Bench model)

- Width 600mm
- Depth 805mm
- Height 915mm
- Incl. splashback 1130mm
- Incl. low back 970mm

NETT WEIGHT

Bench and Leg Stand models

74kg

Cabinet Base models

79kg

PACKING DATA

Bench and Leg Stand models

- 0.37m³, 110kg
- Width 645mm
- Depth 870mm
- Height 665mm

Cabinet Base models

- 0.70m³, 131kg
- Width 870mm
- Depth 645mm
- Height 1255mm

OPTIONS AT EXTRA COST

- Hot Plate elements (replace individual open radiant elements)
- Ribbed griddle plates

**RN8400E-B
BENCH MODEL**

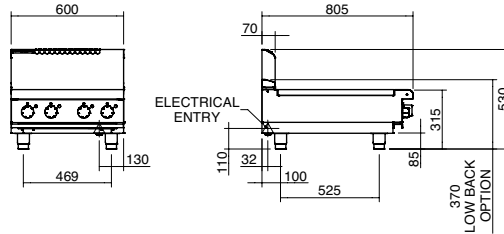

**RN8400E-CB
CABINET BASE**

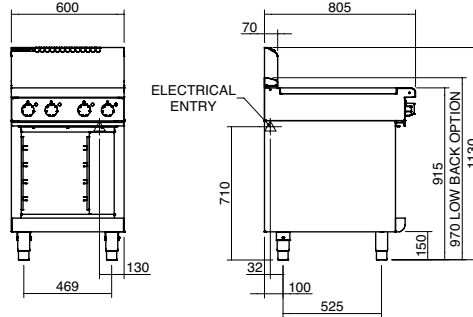

**RN8400E-LS
LEG STAND**

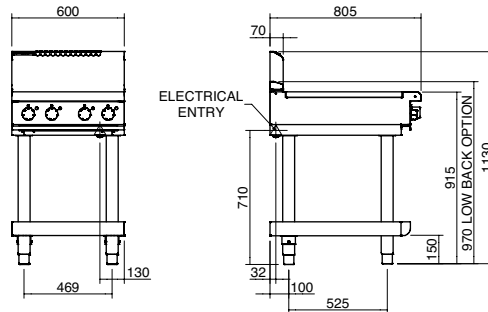

RN8400E

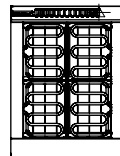

RN8403E

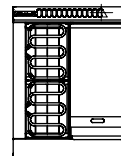

RN8406E

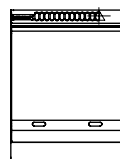

moffat.com.au
moffat.co.nz

Australia
moffat.com.au

Moffat Pty Limited

Victoria/Tasmania
 740 Springvale Road
 Mulgrave, Victoria 3170
 Telephone +613-9518 3888
 Facsimile +613-9518 3833
vsales@moffat.com.au

New South Wales
 Telephone +612-8833 4111
nswsales@moffat.com.au

South Australia
 Telephone +613-9518 3888
vsales@moffat.com.au

Queensland
 Telephone +617-3630 8600
qldsales@moffat.com.au

Western Australia
 Telephone +618-9413 2400
wasaless@moffat.com.au

New Zealand
moffat.co.nz

Moffat Limited

Rolleston
 45 Illinois Drive
 Izone Business Hub
 Rolleston 7675
 Telephone +64 3-983 6600
 Facsimile +64 3-983 6660
sales@moffat.co.nz

Auckland
 Telephone +64 9-574 3150
sales@moffat.co.nz



In line with policy to continually develop and improve its products, Moffat Limited reserves the right to change specifications and design without notice.

© Copyright Moffat Ltd
 AN.W8.08/19

an Ali Group Company



The Spirit of Excellence