

Technical data sheet for

## ELECTRIC GRIDDLE 600mm

GP8600E-B, GP8600E-CB, GP8600E-LS



GP8600E-LS

- Heavy-duty thermostatic electric griddle
- 20mm thick griddle plate
- Ribbed plate options
- Chromed mirror plate options
- Top weld sealed plates
- 7.2kW heating elements
- 3 models of base unit
- Stainless steel exterior
- Easy clean
- Easy service
- Fully modular
- Low back models (GPL) available

### Overall Construction

#### GRIDDLE

- 20mm thick machined top plates standard
- Optional ribbed plate sections
- Optional mirror finish hard chrome plates
- 2.5mm thick 304 stainless steel splash guards sides and rear
- 2.0mm thick grease channel
- Single temperature control zone
- Welded hob surround with 1.5mm 304 stainless steel bull nose
- Splashback and side panels 1.2mm 304 stainless steel
- Front panels 0.9mm 304 stainless steel
- Stainless steel grease drawer
- Overlapping finish at front and rear of plate for easy clean

#### BENCH MOUNT (SUPPLIED AS -B MODEL)

- Four 63mm dia. heavy-duty 1.2mm 304 stainless steel bench legs with adjustable feet
- Adjustable height 80mm – 105mm

#### CABINET BASE (SUPPLIED AS -CB MODEL)

- Fully modular for match suite finish
- Double skin 0.9mm 304 stainless steel interior and exterior
- Optional GN 1/1 4 position racking kit
- 63mm dia. heavy-duty 1.2mm 304 stainless steel legs with adjustable feet

#### LEG STAND (SUPPLIED AS -LS MODEL)

- Fully modular for matched suite finish
- Framed top for connection to Griddle
- 63mm dia. heavy-duty 1.2mm 304 stainless steel legs with adjustable feet
- Fully modular framed stand shelf with 0.9mm 304 stainless steel finish
- Suitable for rear or through shelf gas connection to Griddle
- Quick assembly design (no tools required)

### Controls

- 50-300°C thermostats
- Single temperature control zone
- Large easy use control knob - heat resistant reinforced
- Easy view control settings on knob
- Indicator lights for power and heating

### Cleaning and Servicing

- All models with easy clean stainless steel external finish
- Plate is finished front and rear with overlap construction to remove cleaning traps
- Control service through front of unit

# Technical data sheet for ELECTRIC GRIDDLE 600mm



## Specifications

### Elements

3 x 2.4kW stainless steel sheathed heating elements

### Electrical requirements

7.2kW

230-240Vac, 50/60Hz, 1P+N+E, 30A

### Plate

Cooking surface 592mm x 530mm, 3138cm<sup>2</sup>

### Electrical connection

130mm from RH side, 32mm from rear, and 740mm from floor

### DIMENSIONS

#### Bench models

Width 600mm

Depth 805mm

Height 315mm

Incl. splashback 530mm

Incl. low back 370mm

#### All models (excluding Bench model)

Width 600mm

Depth 805mm

Height 915mm

Incl. splashback 1130mm

Incl. low back 970mm

### NETT WEIGHT

Bench and Leg Stand models

118kg

Cabinet Base models

120kg

### PACKING DATA

#### Bench models

0.37m<sup>3</sup>, 170kg

Width 645mm

Depth 870mm

Height 665mm

#### All models (excluding Bench model)

0.70m<sup>3</sup>, 172kg

Width 645mm

Depth 870mm

Height 1255mm

### OPTIONS AT EXTRA COST

Joining caps

Castors

Plinth mounting

Ribbed plate options

Chromed plate options

**GP8600E-B  
BENCH MODEL**

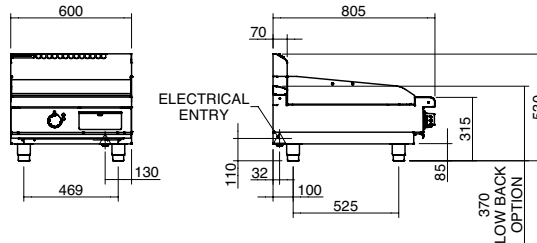

**GP8600E-CB  
CABINET BASE**

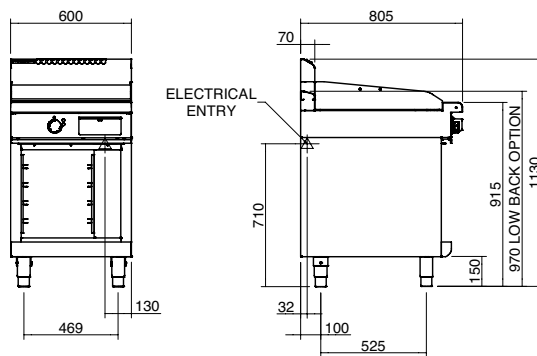

**GP8600E-LS  
LEG STAND**

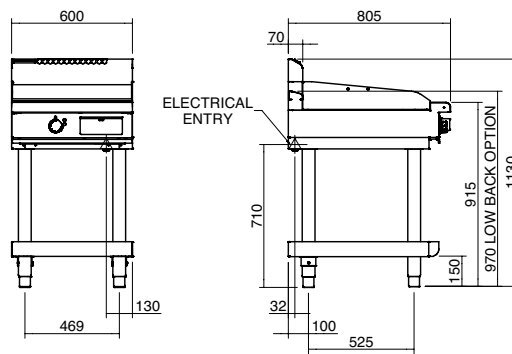

**PLAN**

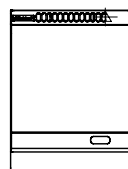

[moffat.com.au](http://moffat.com.au)  
[moffat.co.nz](http://moffat.co.nz)

**Australia**  
[moffat.com.au](http://moffat.com.au)

### Moffat Pty Limited

Victoria/Tasmania  
740 Springvale Road  
Mulgrave, Victoria 3170  
Telephone +613-9518 3888  
Facsimile +613-9518 3833  
[vsales@moffat.com.au](mailto:vsales@moffat.com.au)

New South Wales  
Telephone +612-8833 4111  
[nswsales@moffat.com.au](mailto:nswsales@moffat.com.au)

South Australia  
Telephone +613-9518 3888  
[vsales@moffat.com.au](mailto:vsales@moffat.com.au)

Queensland  
Telephone +617-3630 8600  
[qldsales@moffat.com.au](mailto:qldsales@moffat.com.au)

Western Australia  
Telephone +618-9413 2400  
[wasales@moffat.com.au](mailto:wasales@moffat.com.au)

**New Zealand**  
[moffat.co.nz](http://moffat.co.nz)

### Moffat Limited

Rolleston  
45 Illinois Drive  
Izone Business Hub  
Rolleston 7675  
Telephone +64 3-983 6600  
Facsimile +64 3-983 6660  
[sales@moffat.co.nz](mailto:sales@moffat.co.nz)

Auckland  
Telephone +64 9-574 3150  
[sales@moffat.co.nz](mailto:sales@moffat.co.nz)



In line with policy to continually develop and improve its products, Moffat Limited reserves the right to change specifications and design without notice.

© Copyright Moffat Ltd  
AN.W8.08/19

an Ali Group Company



The Spirit of Excellence