

## Gas Chargrill 450mm

CHLB8450G-B, CHLB8450G-LS, CHLB8450G-CD



CHLB8450G-CD

- Heavy-duty construction
- Reversible heavy-duty top grates
- Interchangeable drop on griddle plates
- 48MJ/hr stainless steel burner on 450mm model
- Stainless steel exterior
- Black vitreous enamel finish to front panels
- Easy clean
- Easy service
- Fully modular

### Series Options

- CHLB - Low back models  
CHB - 215mm splashback option

### OVERALL CONSTRUCTION

#### CHARGRILL

- 2.5mm thick 304 stainless steel side splash guards
- Welded 1.5mm 304 stainless steel bull nose
- Welded splashback and side panels 1.2mm 304 stainless steel
- Front panels 0.9mm 304 stainless steel
- Front grease channel
- Welded 1.2mm 304 stainless steel grease drawers
- 1.5mm hot rolled steel burner box
- Aluminised steel grease drawer baffles
- Insulated sides

#### BENCH MOUNT (SUPPLIED AS -B MODEL)

- Four 63mm dia. heavy-duty 1.2mm 304 stainless bench legs with adjustable feet
- Adjustable height 80mm-105mm

#### LEG STAND (SUPPLIED AS -LS MODEL)

- Fully modular for matched suite finish
- Framed top for connection to Chargrill
- 63mm dia. heavy-duty 1.2mm 304 stainless steel legs with adjustable feet
- Fully modular framed stand shelf with 0.9mm 304 stainless steel finish
- Quick assembly design (no tools required)

#### CABINET BASE (SUPPLIED AS -CD MODEL)

- Fully modular for matched suite finish
- Double skin 0.9mm 304 stainless steel interior and exterior
- 1/1GN 4 position racking
- 63mm dia. heavy-duty 1.2mm 304 stainless steel legs with adjustable feet

#### GRATES AND RADIANTS AND BAFFLES

- 150mm wide x 550mm top grate sections
- Top grates reversible for level or inclined use
- Inclined position incorporates flare reducing grate fin design with grooves to run grease into front collection channel
- Heavy weight castings for high demand performance
- Heavy-duty high efficiency cast iron burner radiants
- Improves heat retention and protects burners
- Baffles over grease drawers to reduce grease collection flare ups

#### GRIDDLE PLATES

- Optional extra 300mm wide x 550mm deep drop on cast iron griddle section.
- Machined smooth surface finish
- Interchangeable in any position with 2 sections of top grate

#### BURNERS

- Full 304 stainless steel burners
- 1 x 48MJ/hr stainless steel burner
- Removable for cleaning
- Full pilot and flame failure protection per burner

#### CONTROLS

- Individual Hi-Lo gas control to each burner with flame failure and pilot
- Large easy use control knob - heat resistant reinforced
- Easy view control settings on knob
- Piezo ignition to pilot burner

#### CLEANING AND SERVICING

- Easy clean stainless steel external finish
- Lift out radiants, burners and grease tray baffles
- All burner box interior parts lift out for full cleaning access
- Deep stainless steel grease collection drawers
- Access to all parts from front of unit

## Gas Chargrill 450mm



moffat.com.au  
moffat.co.nz

CHLB8450G-LS/CD

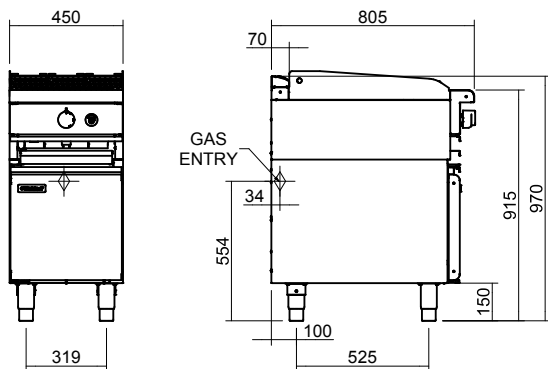

CHLB8450G

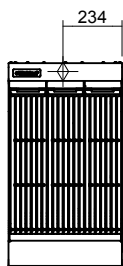

### SPECIFICATIONS

#### Burners

48MJ/hr 304 stainless steel bar burner

#### Gas power (gross)

48MJ/hr, 14kW

#### Cooking surface area

442mm x 500mm, 2210cm<sup>2</sup>

#### Gas connection

R 3/4 (BSP) male

216mm from LH side, 32mm from rear, and 555mm from floor

All units supplied with Natural and LP gas regulator

#### Dimensions

Width 450mm

Depth 805mm

Height 915mm

Incl. low back 970mm  
(Bench models 470mm)

Incl. splashback option 1130mm  
(Bench models 630mm)

#### Nett weight

Bench/Leg Stand models

99kg

Cabinet Base model

99kg

#### Packing data

Bench/Leg Stand models

0.29m<sup>3</sup>, 133kg

Width 870mm

Depth 495mm

Height 855mm

Cabinet Base model

0.54m<sup>3</sup>, 139kg

Width 870mm

Depth 495mm

Height 1255mm

#### Gas types

Available in Natural gas and LP gas

Please specify when ordering

Units supplied complete with gas type conversion kits

Other gas types on request

#### OPTIONS AT EXTRA COST

Griddle plates 300mm drop on

Joining caps

Castors

Plinth mounting

Straight grates

### Australia

moffat.com.au

#### Moffat Pty Limited

Victoria/Tasmania  
740 Springvale Road  
Mulgrave, Victoria 3170  
Telephone +613-9518 3888  
Facsimile +613-9518 3833  
vsales@moffat.com.au

New South Wales  
Telephone +612-8833 4111  
nswsales@moffat.com.au

South Australia  
Telephone +613-9518 3888  
vsales@moffat.com.au

Queensland  
Telephone +617-3630 8600  
qldsales@moffat.com.au

Western Australia  
Telephone 618-9413 2400  
wasales@moffat.com.au

### New Zealand

moffat.co.nz

#### Moffat Limited

Rolleston  
45 Illinois Drive  
Izone Business Hub  
Rolleston 7675  
Telephone +64 3-983 6600  
Facsimile +64 3-983 6660  
sales@moffat.co.nz

Auckland  
Telephone +64 9-574 3150  
sales@moffat.co.nz



ISO9001  
Quality  
Management  
Standard

Designed and manufactured by



ISO9001

All Waldorf Bold products are designed and manufactured by Moffat using the internationally recognised ISO9001 quality management system, covering design, manufacture and final inspection, ensuring consistent high quality at all times.

In line with policy to continually develop and improve its products, Moffat Limited reserves the right to change specifications and design without notice.

© Copyright Moffat Ltd  
AN.WBD.S.02.19

an Ali Group Company



The Spirit of Excellence