

Technical data sheet for

FAST FRI FILTAMAX

FF8130E, FF8135E, FF8140E



- Mobility and space saving features
- Powerful reversible $\frac{1}{3}$ HP pump
- Full stainless steel construction
- Reusable filter bag
- Upgrade kit to carbon pad filtering
- Easy clean
- Easy service

Overall Construction

- Full stainless steel construction
- Mounted on two fixed and two swivel castors
- $\frac{1}{3}$ HP motor, reversible, heavy duty pump
- Heavy duty motor switch
- Rigid return delivery tube for safe, efficient, return of oil and shortening to fryer tank
- Reusable 'easy clean' filter bags, with upgrade kit to carbon pad filtering available
- Heavy duty stainless steel handle
- Cord storage
- Heavy duty heat resistant handle fitted to oil delivery tube

Controls

- Off/Forward/Reverse pump control
- Cord set fitted

Cleaning and Servicing

- Open stainless steel pan for easy clean
 - Easy clean stainless steel exterior
-

Technical data sheet for FAST FRI FILTAMAX



Specifications

Pump

1/3 HP single phase reversible pump

Electrical requirements

220 - 240 V.a.c., 50/60 Hz, 1 P+N+E, 3.2A

110 - 120 V.a.c., 50/60 Hz, 1 P+N+E, 6.4A

Electrical connection

62mm from RH side, 365mm from rear, and 440mm from floor

FILTERING CAPACITY

FF8130E 20 litres

FF8135E 30 litres

FF8140E 32 litres

FRYER COMPATABILITY

FF8130E FN8120G/GE

FN8226G/GE

FN8123E/EE

FN8127E/EE

FN8223E

FN8224E/EE

FN3050ECS

FN3052ECS

FF8140E FN8130G/GE

FN8130G HPO

UNDER FRYER STORAGE

FF8130E FN8120G/GE

FN8226G/GE

FF8135E N/A

FF8140E FN8130G/GE

FN8130G HPO

DIMENSIONS

FF8130E

Width 324mm

Depth 683mm

Height 562mm

FF8135E

Width 324mm

Depth 735mm

Height 562mm

FF8140E

Width 474mm

Depth 683mm

Height 562mm

NETT WEIGHT

FF8130E

24kg

FF8135E

26kg

FF8140E

28kg

PACKING DATA

FF8130E

0.28m³, 51kg

FF8135E

0.28m³, 53kg

FF8140E

0.28m³, 55kg

OPTIONS AT EXTRA COST

Additional filter bags

Carbon pad upgrade kit (Part No. 025669)

Flexible hose with stay cool handle (Part No. 020417)

Drain adaptor kit (Part No. 024705) and drain extension kit (Part No. 024710) available for using FF8140E for combined 450mm + 600mm wide Waldorf fryer filtering applications.

FF8130E

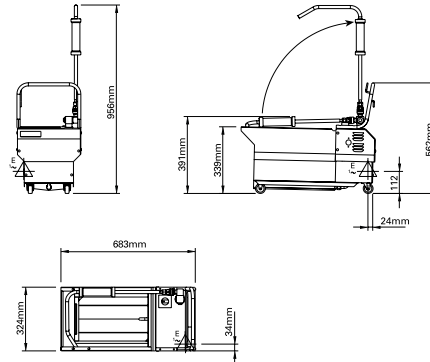

FF8135E

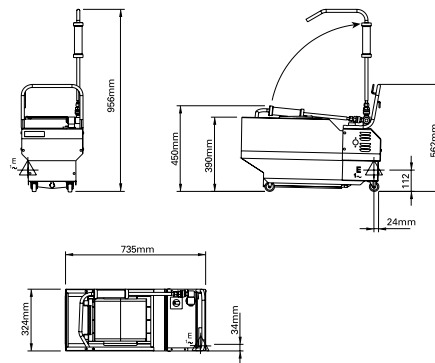

FF8140E

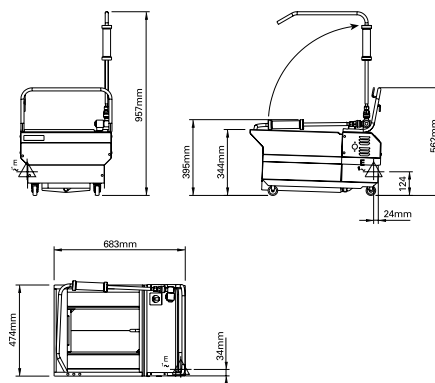

moffat.com.au

moffat.co.nz

Australia

moffat.com.au

Moffat Pty Limited

Victoria/Tasmania

740 Springvale Road

Mulgrave, Victoria 3170

Telephone +613-9518 3888

Facsimile +613-9518 3833

vsales@moffat.com.au

New South Wales

Telephone +612-8833 4111

nswsales@moffat.com.au

South Australia

Telephone +613-9518 3888

vsales@moffat.com.au

Queensland

Telephone +617-3630 8600

qldsales@moffat.com.au

Western Australia

Telephone +618-9413 2400

wasales@moffat.com.au

New Zealand

moffat.co.nz

Moffat Limited

Rolleston

45 Illinois Drive

Izone Business Hub

Rolleston 7675

Telephone +64 3-983 6600

Facsimile +64 3-983 6660

sales@moffat.co.nz

Auckland

Telephone +64 9-574 3150

sales@moffat.co.nz



ISO9001

Quality

Management

Standard

In line with policy to continually develop and improve its products, Moffat Limited reserves the right to change specifications and design without notice.

© Copyright Moffat Ltd

AN.W8.08/19

an Ali Group Company



The Spirit of Excellence