

WBCF10

**INDUSTRY
KITCHENS**

www.industrykitchens.com.au 1800 611 058



CATEGORY	BLAST CHILLER/FREEZERS
RANGE	Blast Chiller Reach In
UNIT	CHILLER/FREEZER
TYPE	SELF CONTAINED
DOORS	1

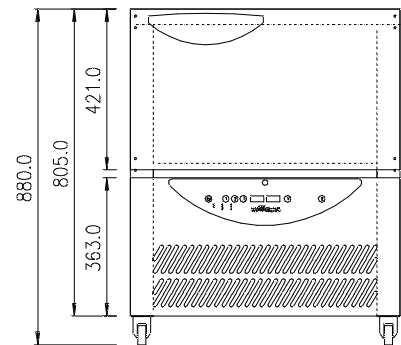
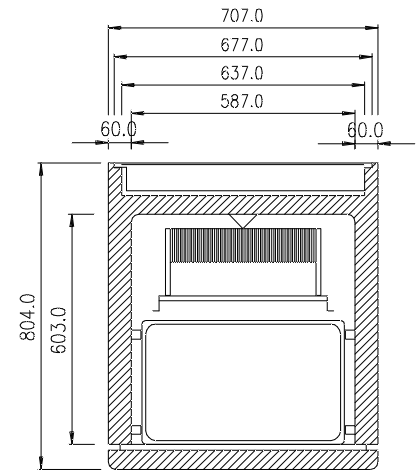
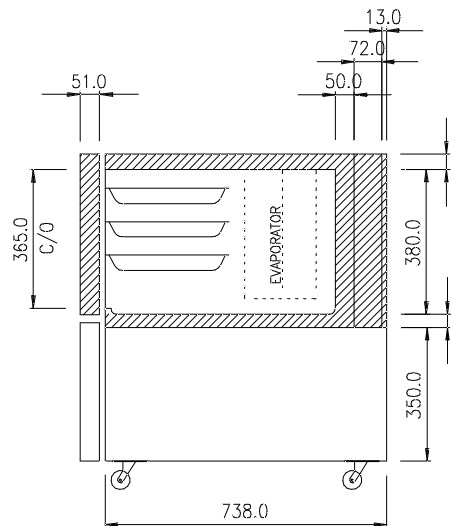

SPECIFICATIONS

CAPACITY - CHILLING/FREEZING PER 90/240 MIN CYCLE #	10 kg
CAPACITY - 1/1 GN PANS	3
DIMENSIONS - W X D X H (ON CASTORS) MM	707 W x 804 D x 880 H
WEIGHT UNPACKED (KG)	50
DOOR TYPE	Standard: SD (Solid Door)
FINISH (INTERIOR AND EXTERIOR EXCLUDING REAR AND UNDER)	SS (Stainless Steel)
SHELF SLIDES TO SUIT 1/1 GN PANS AND SHELVES	3
ELECTRICAL	
POWER SUPPLY	10 amp
POWER CABLE LENGTH (METRES)	2
RUNNING AMPS	4.0
GAS TYPE	
REFRIGERANT	R404a

Based on Blast chilling of 50 mm max depth of uncovered dense food such as mashed potato. Times will vary depending on the container and food types as well as the thermal conductivity of the food.