

# HE2USSBA

# INDUSTRY KITCHENS

www.industrykitchens.com.au 1800 611 058



CATEGORY FOODSERVICE COUNTERS

RANGE **Emerald**

UNIT REFRIGERATOR

TYPE SELF CONTAINED

DOORS 2

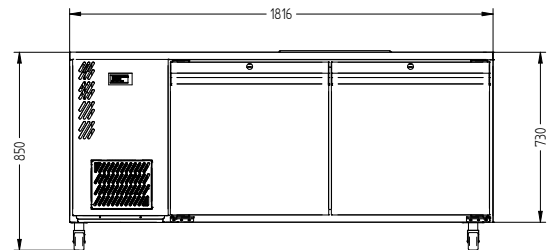
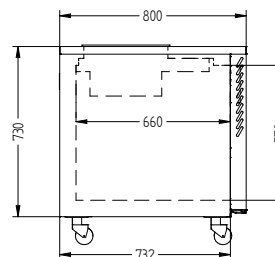
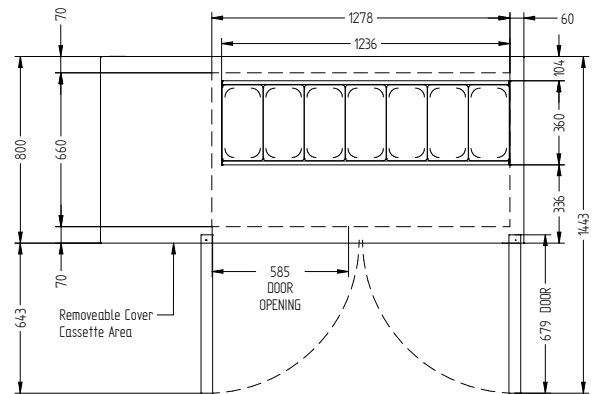
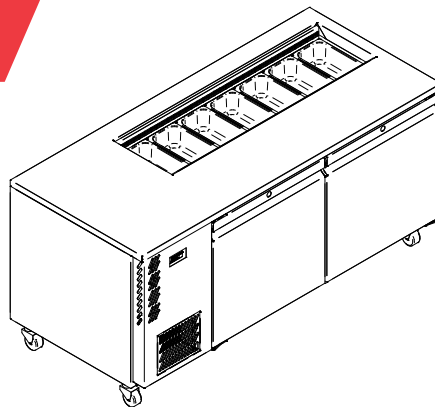

## SPECIFICATIONS

CAPACITY LITRES	610
TEMPERATURE	1°C / 4°C
FRONT BREATHING	YES
DIMENSIONS - W X D X H (ON 120MM H CASTORS) MM	1815 W x 800 D x 850 H
WEIGHT UNPACKED (KG)	160

## STANDARD INCLUSIONS \*\*\*

DOOR TYPE	Standard: SD (Solid Door)    Optional: DR (Drawer)
FINISH (INTERIOR AND EXTERIOR EXCLUDING REAR AND UNDER)	SS (Stainless Steel)
SHELVES/DOOR	1
BLOWN AIRWELL (100MM DEEP 1/3 PANS INCLUDED)	7 X 1/3 PANS

## ELECTRICAL

POWER SUPPLY	10 amp	
BLOWN AIRWELL MODELS	RUNNING AMPS	4.6

## GAS TYPE

REFRIGERANT	FRIDGE MODELS	R134a
-------------	---------------	-------

\*\*\* For **OPTIONS** refer to the current Williams Price Guide