

Food Blender

Brand: Vitamix

Model Number: Vitamix XL

Dimensions: 216mm (W) x 483mm (D) x 459mm (H)

Included Container: 5.6 L XL Container



Description

Maximise your kitchen's possibilities with the largest capacity, countertop food blender. Blend up to 24 (240 ml) servings at once. The XL is engineered to reduce prep time, improve staff efficiency, and expand your menu capabilities. Featuring basic variable speed functions with 10 speed options and a pulse inclusion, you can create culinary masterpieces with ease. The Vitamix XL's powerful 4.2-peak output HP motor ensures reduced noise, improved reliability and minimised downtime. The starter kit includes the Vitamix XL blender with 5.6 L heavy-duty container, XL blade assembly, two-piece lid and tamper stick to move ingredients towards the blade. The Vitamix XL is covered by a 3 year back to base warranty (1 year parts and labour and 2 years parts only) on the motor base. Containers and blades are subject to a 12 month manufacturer's defect warranty. Best suited to: Restaurants, Hotels, Nursing Homes, Hospitals, Catering Companies, Cafes, Production Kitchens, Schools.

Supplied Accessories



5.6 L XL Container with
Lid and Blade Assembly



Tamper Stick



Terms and Conditions apply. 3 years parts, 1 year labour.
Containers and blades are subject to a 12 month manufacturer's defect warranty.



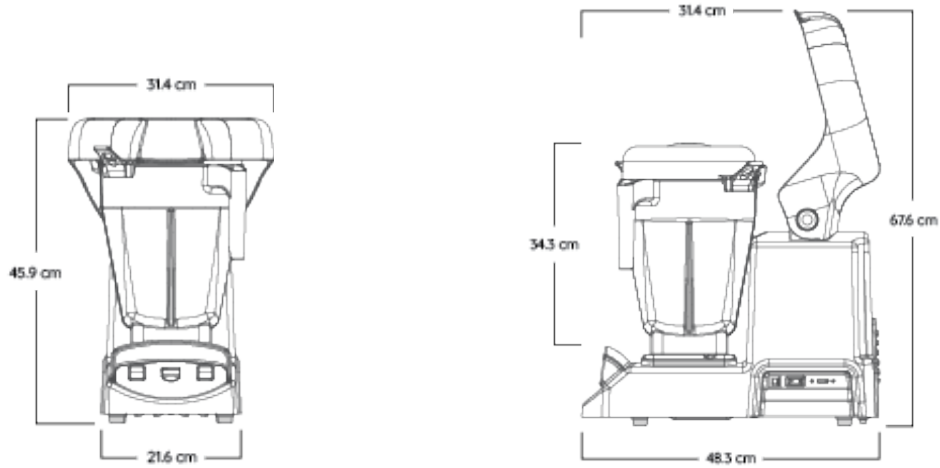

Machine

Type	Food
Colour	Black
Container	5.6 L XL
Blade	XL
Material	BPA-free plastic

Dimensions

	External	Packed	Operating Space
Height (mm)	459	TBC	676
Width (mm)	216	TBC	314
Depth (mm)	483	TBC	483

Weight

	Machine	Packed
Gross (kg)	20.64	TBC

Performance

Functions	Basic variable speed functions
Speed	10 speed options
Pulse Option	Yes

Electrical

Motor - Peak Output (HP)	4.2
Power - Load Dependent (Watts)	TBC
Electrical Connection	10 Amp plug with 2.1 m flex
Frequency (Hz)	50
Voltage	230

Optional Accessories

Container with Lid and Blade	5.6 L XL Container with Lid and XL Blade Assembly (Part No. VIT-016066-3221)
Container with Lid and Blade	2 L XL Container with Lid and XL Blade Assembly (Part No. VIT-015894-1205)
Container	5.6 L XL Container (Part No. VIT-015896)
Container	2 L XL Container (Part No. VIT-015893)
Lid	2 Piece Lid for 5.6 L XL Container (Part No. VIT-016067)
Lid	2 Piece Lid for 2 L XL Container (Part No. VIT-015892)
Blade Assembly	XL Blade Assembly for 5.6 L Container (Part No. VIT-015897)
Blade Assembly	XL Blade Assembly for 2 L Container (Part No. VIT-015941)
Rinse-o-Matic	Sink mounted container cleaner (Part No. VIT-001446)
Nut Wrench	Plastic Retainer Nut Wrench (Part No. VIT-015596)



Vitamix XL
on the SKOPE website

