

Varimixer

# TEDDY

INDUSTRY  
KITCHENS

[www.industrykitchens.com.au](http://www.industrykitchens.com.au) 1800 611 058

**EASY CLEANING** Its die-cast, rounded design and no external screws or openings make TEDDY easy to clean.

**ATTACHMENT DRIVE** TEDDY is also available in white with an attachment drive for mounting a stainless steel meat mincer.

**SAFETY SCREEN** A fixed grille and a detachable filling tray and splash guard protect both the operator and the ingredients, while allowing the mixing process to be monitored.

**EFFECTIVE TOOLS** TEDDY comes with a 5-litre stainless steel mixing bowl with a lid, a wire whip made of 2.5 mm wire, a beater and a specially designed hook which ensures dough is kneaded and turned to perfection. All accessories are made of stainless steel and are dishwasher-safe.

**AFFIXED BOWL** The bowl is held effectively in place during operation by a single lever.

**EASY OPERATION** Speed is infinitely adjusted using the pass-through control knob, which allows TEDDY to be operated from either side. The knob is also the click-lock and hinge point when the mixer head is tilted back to change tools.

**GOOD STABILITY** A wide footprint and suction cups ensure the mixer is stable during operation.



## VARIMIXER TEDDY 5L COLOR OPTIONS



Pure white



Racing red



Piano black



Silver grey

## OPTION - ATTACHMENT DRIVE



Pure white - with attachment drive



Meat mincer, stainless steel,  
62 mm

## TOOLS INCLUDED

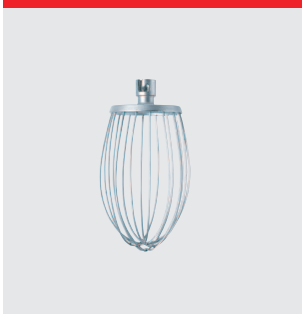

Whip, stainless steel

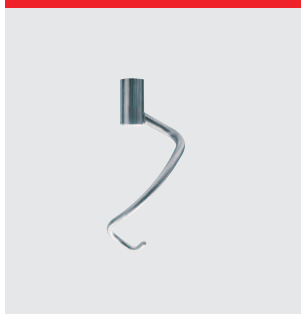

Hook, stainless steel

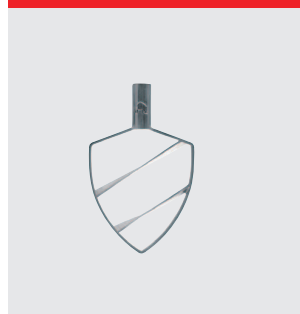

Beater, stainless steel

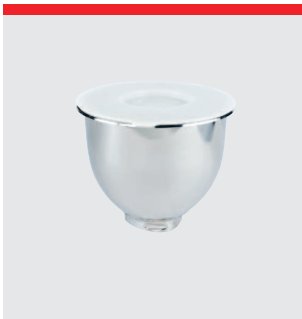

Bowl, stainless steel and lid



Splash guard



Filling chute

### VARIMIXER TEDDY 5L

Powder coated  
1 bowl 5 liter in stainless steel  
1 beater in stainless steel  
1 hook in stainless steel  
1 whip in stainless steel  
1 removable splash guard in plastic  
1 filling chute  
1 lid for bowl  
Voltage: 1 ph, 220-240V, 50-60 Hz. 500 W

### VARIMIXER TEDDY 5L TECHNICAL DATA

Volume	5 l
Effect	500 W
Standard voltage*	220-240 V
Net weight	18 kg
H x W x L	400x240x462 mm
Variable speed	78-422 RPM
Phases	1 ph
IP code	IP42

\*Other voltage power supply are available upon request in the range of 100 to 480 V.  
All standard and marine mixers are available in 50 and 60 Hz.

### CAPACITIES

Egg whites	0.7 l
Whipped cream	1.5 l
Mayonnaise	4.4 l
Herb butter	1.7 kg
Mashed potatoes	2.5 kg
Bread dough (50% AR)	2.5 kg
Bread dough (60% AR)	2.5 kg
Ciabatta dough (70% AR)	3.0 kg
Muffins	2.5 kg
Layer cake base	1.0 kg
Meatball mix	3.0 kg
Icing	2.9 kg
Doughnut (50% AR)	2.5 kg

### DIMENSIONS

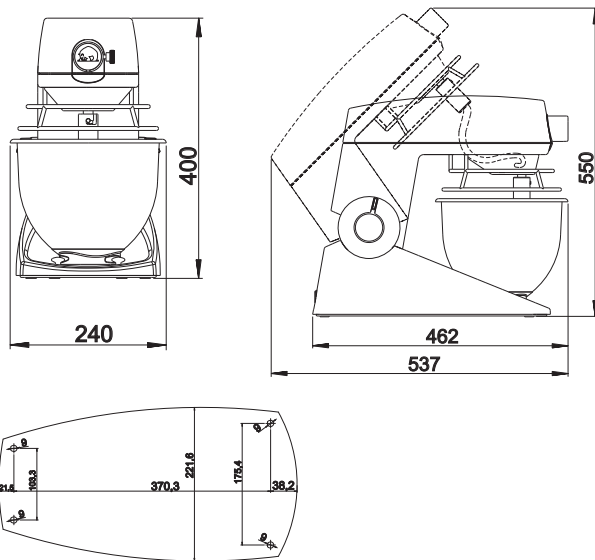

### CERTIFICATONS



# Varimixer

A/S Wodschow & Co  
Kirkebjerg Søpark 6  
DK-2605 Brøndby  
P: +45 4344 2288  
E: info@varimixer.com  
www.varimixer.com