

Varimixer

# ERGO60

INDUSTRY  
KITCHENS

[www.industrykitchens.com.au](http://www.industrykitchens.com.au) 1800 611 058

**ERGONOMIC HANDLING** Separate removal of bowl and tools. The taller frame allows you to lower the bowl below the tool, so each of them can be removed separately, increasing efficiency.

**CONTROL PANEL** Choose between variable speed control, fixed speeds or up to 24 programs with their own processes. All operations are controlled from the intuitive, angled touch panel control panel. The panel is easy to clean and is dustproof and waterproof.

**REMOVABLE SAFETY GUARD** The removable safety guard is made of stainless steel and is easy to remove and dishwasher safe.

**ERGONOMIC WORKING HEIGHT** All work at Varimixer ERGO is done with a straight back. There is unhindered access to changing tools at the correct ergonomic working height.

**ONE MACHINE – MULTIPLE CAPACITIES** The ERGO60 is also available with a bowl and tools for 30-litre production. The option of producing reduced quantities makes the large machines more versatile.

**AUTOMATIC BOWL LOWERING** It is not necessary to watch the mixing process. When the time is up, the control system lowers the bowl, so the tools can drip off directly into the bowl.

**LIFT FOR EASY HANDLING** Even the largest bowls can be easily and ergonomically lifted using an electronic bowl lift, which also ensures correct working height during filling and emptying. Choose from several models - or choose a manual bowl trolley for transport only.

**HYGIENIC AND EASY TO CLEAN** ERGO 60 is available in white or stainless steel. All accessories are made of stainless steel, and the design ensures the best possible hygiene and very easy cleaning. Varimixer ERGO can be washed in accordance with the IP53 standard, and can be upgraded to IP54, with a waterproof stainless steel planetary head.



**NO HEAVY LIFTING** The bowl is wheeled into place between the two bowl arms. The bowl is automatically centered and locked into position, when raised.



## ERGO VL-5 - Next generation - New functions

### Introducing the next generation ERGO series and AR200

Compared to the previous version VL-4, the new VL-5 version has been upgraded with the following innovative unique features:

- **New self-lubricating lifting motor**  
for a service free extended lifetime.
- **Extended bayonet system**  
for increased contact surface area with the mixing tools. This will reduce wear on both bayonet and mixing tools and extend their lifetime
- **USB service port**  
for fast and secure software upgrades, recipe downloads, workload data history and much more.
- **All new VL-5 control panel**  
with multilingual screen, individual interfaces, recipes and control options. Direct access to online user- and service manuals.
- **Environment friendly produced**  
Every detail, from the choice of IE3 motor to recyclable packing and the total lifetime expectancy of this product, has been carefully evaluated to minimize the environmental impact of this product line.



# New VL-5 Control Panel

Touch panel to operate:

ERGO60 · ERGO100 · ERGO140 · AR200



Programmed receipts can be upload via USB. Excel or Google Sheets can be used as a programmable editor.



**USB - IP65 Protection**

## FEATURES

- Auto switch to large time counter
- Lowering the bowl down via the arrows on the screen
- Direct time setting by pressing the clock
- Favorite buttons for quick start of selected recipe
- 24 programs available
- Programming can be done on the control panel
- Programming can be done on a PC with subsequent upload to the machine using USB
- Readout of operating data on panel or for download via USB
- USB connector on the machine for uploading recipes
- USB connector on machine for download
- Optional PIN code protection of recipes
- Access to operating instructions and video instructions via QR codes
- Language selection of control panel



# ERGO - VL-5 Control Panel - Highlights



## VL-5 Main Menu - Easy access to:

- Start / Stop
- Bowl Lowering
- Time settings
- Speed setting
- Favorites



## VL-5 Submenu - Easy access to:

- Recipes
- Settings
- Operating Instructions
- Operating log
- Alarms



## VL-5 Menu - Recipes:

Favorite buttons for quick start of selected recipes.

Edit recipe on the screen or make them in Excel and upload them via the USB input port.

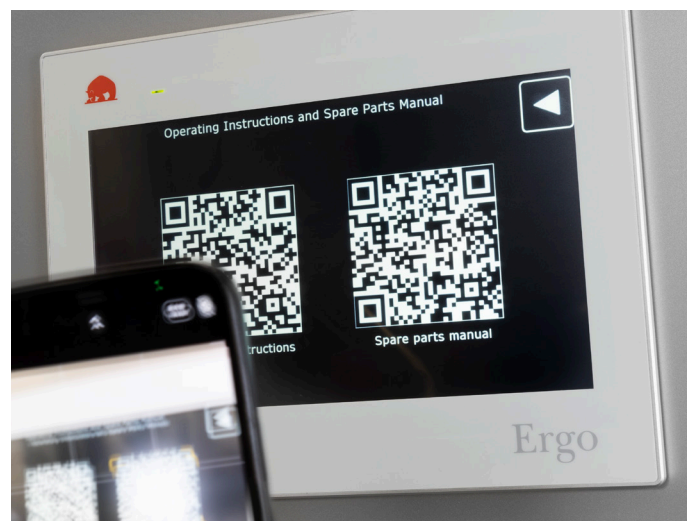

## VL-5 Menu - Spare parts manual:

Access the ERGO spare parts manual via the QR Code displayed on the control panel



## Lowering the bowl up and down

Press the side left/right buttons simultaneous



**VARIMIXER ERGO 60 OPTIONS – MODELS**



White, powder coated



Stainless steel



Marine version

**OPTION – IP54**



Waterproof planetary head, stainless steel, IP54

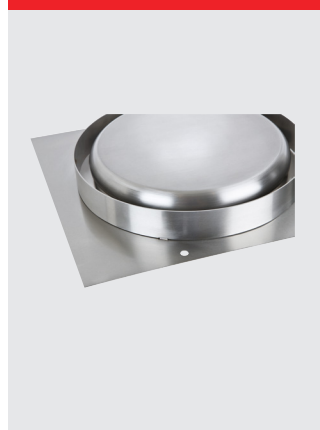

Air ventilation - Double layer protected, stainless steel, IP54

**OPTIONS – SAFETY GUARDS**



Removable safety guard in stainless steel. CE-certified

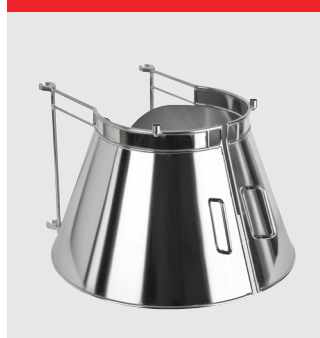

Removable splash guard in stainless steel. CE-certified

**VARIMIXER ERGO 60 STANDARD TOOLS – A-EQUIPMENT 60L**

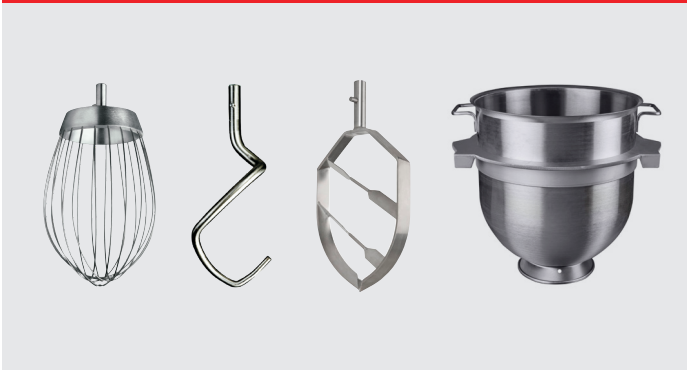

Whip, hook, beater and bowl 60 liter in stainless steel.

**VARIMIXER ERGO 60 STANDARD TOOLS – B-EQUIPMENT 60/30L**

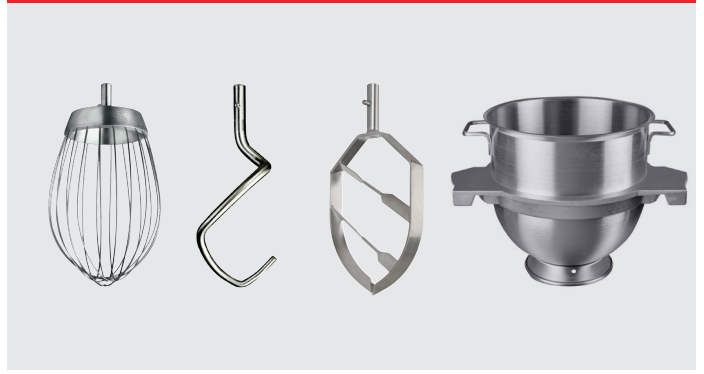

Whip, hook, beater and bowl 60/30 liter in stainless steel.

**OPTION – TOOLS**



Wing whip, stainless steel



Whip with thinner wires, stainless steel



Whip with reinforcement



Powder mixer, stainless steel



Automatic scraper, stainless steel. 60L and 60/30L.



Tool rack, 127 cm

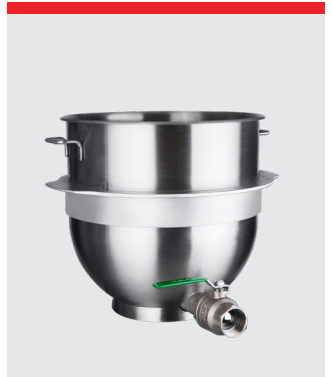

Bowl with bottom draining pipe, stainless steel

**EQUIPMENT – TRANSPORTION**



Bowl truck



Easylift 30-60



Flexlift Inox



Wheels for bowl

## VARIMIXER ERGO60 STANDARD

White powder coated
1 bowl 60 liter in stainless steel
1 beater in stainless steel
1 hook in stainless steel
1 whip with stainless steel wires
Removable safety guard in stainless steel – CE-certified
Separate removal of bowl and tool
Digital timer and emergency stop
Voltage: 3 ph, 400V, 50 Hz with ground. 3.000 W

## VARIMIXER ERGO60 STANDARD TECHNICAL DATA

Volume	60 l
Effect	3.000 W
Voltage*	400 V
Residual current devices (RCD): Industrial environment Light industry/domestic	HPFI type A-SI or PFI type B PFI type B
Net weight	330 kg
Shipping gross weight	380 kg
H x W x L (Shipping dimensions)	2270 x 850 x 1320 mm
H x W x L (Product dimensions)	1848 x 761 x 1105 mm
HS Code	84341010
Vol. m <sup>3</sup>	2.55 m <sup>3</sup>
Ldm	0.50
Variable speed	53 – 292 RPM
Phases	3 ph
IP code	IP53
IP code upgrade	IP54

\*Other voltage power supply are available upon request in the range of 200 to 480 V. All standard and marine mixers are available in 50 and 60 Hz.

## VARIMIXER ERGO60 MARINE VERSION

Stainless steel execution, water cover at air ventilation, slotted free screws, full welded stainless steel knees, gasket at the rear plate, gasket at front panel and top cover. Complies with USPHS.

Voltage: 3 ph, 440V, 50 Hz with ground. 3.000 W  
3 ph, 480V, 50 Hz with ground. 3.000 W

## DIMENSIONS

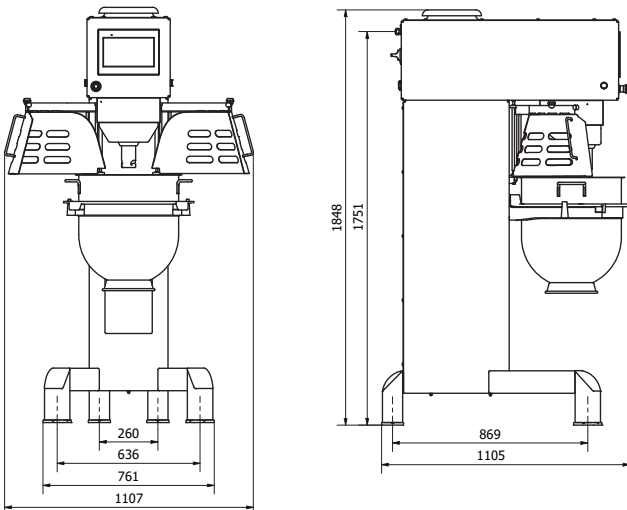

# Varimixer

Varimixer A/S  
Elementfabrikken 9  
DK-2605 Brøndby  
P: +45 4344 2288  
E: info@varimixer.com  
www.varimixer.com

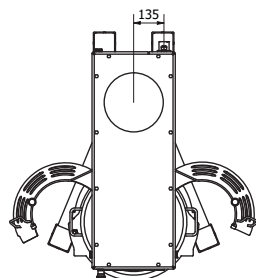

## CAPACITIES

Tools	Product	Special attention
Whip	Egg Whites	3 l
	Whipped cream	12 l
	Buttercream frosting	24 l + □
	Layer Cake Sponges	16 kg
	Mayonnaise	24 l +
Beater	Mashed potatoes	32 kg +
	Cakes	30 kg
	Icing, Fondant	24 kg +
	Herb Butter	18 kg + □
	Meatball / Vegan meatball mix	36 kg +
Hook	Pasta, noodles (50%AR)	24 kg ●
	Dough, wheat (50%AR)	34 kg ●
	Dough, wheat (55%AR)	35 kg ●
	Dough, wheat (60%AR)	40 kg ●
	Dough, whole wheat (70%AR)	36 kg
	Dough, rye bread	42 kg +
	Dough, sourdough bread	36 kg
	Dough, gluten free	28 kg

The capacity chart shows the maximum capacity for the specific machine. The testing has been conducted with standard equipment. Therefore, the use of special tools, can result in a different outcome. Always start the machine at the lowest speed. Increase the speed subsequently, taking the product being mixed into account.

Symbols explainer - Recommended actions:

- + = Apply scraper, for the best and most efficient result
- = Always make sure the ingredients are room temperature/soft. If not, this can damage the tools.
- = Recommended to work on low speed.
- = Recommended not to go above medium speed.
- AR = Absorption Ratio (moisture in % of dry matter)

## CERTIFICATIONS

