

Varimixer

# AR80

## INDUSTRY KITCHENS

[www.industrykitchens.com.au](http://www.industrykitchens.com.au) 1800 611 058

**STRONG AND EFFECTIVE** The powerful motors have the capacity to handle large quantities of heavy ingredients.

**VARIABLE SPEED CONTROL** The speed is variably controlled by a very rugged system of belts, rather than gears. This solution means that the mixer does not contain oil, thus avoiding the risk of oil spilling into the bowl.

**MULTIPLE CAPACITIES IN ONE MACHINE**

Bowls and tools for production at half volume are available for AR80.

**DIGITAL TIMER** operation time can be controlled or monitored via a digital timer. The machine stops at 00:00

**MEAT MINCER AND VEGETABLE CUTTER**

Models from AR30 to AR80 can be ordered with an attachment drive, to expand the mixer's potential applications.

**PLASTIC OR STAINLESS STEEL SAFETY GUARD**

The AR series comes with a CE-approved safety guard made of plastic to prevent flour dust and stains. It's filling chute can be used during operation. It is also available with a removable plastic guard, or a fixed or removable stainless steel guard.

**AUTOMATIC FIXATION** The bowl is wheeled into place between the two bowl arms. Using the handle – or automatically by pressing a button – the bowl is raised, centered and locked in place in a single movement.

**EASY BOWL HANDLING** Choose between bowl trolley for transport or an electric bowl lift, which handles transport to and from the machine. This also ensures good ergonomics during filling and emptying. Choose between several models.

**WHITE OR STAINLESS STEEL** An easy-to-clean design. The AR series is powder coated as standard and can be upgraded to a completely stainless steel frame.



**VARIMIXER AR80 OPTIONS – MODELS**



White, powder coated



Stainless steel



Marine version, stainless steel

**OPTIONS – CONTROL PANEL**



VL-1 – Manual speed regulation and manual bowl lowering



VL-1S – Automatic speed regulation and automatic bowl lowering

**OPTIONS – SAFETY GUARDS**



Fixed safety guard in plastic. CE-certified



Removable safety guard in plastic. CE-certified

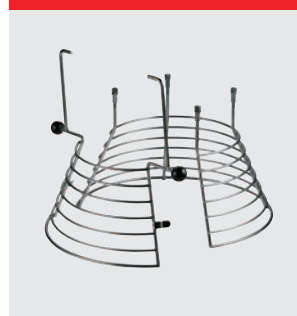

Fixed safety guard in stainless steel. Not CE-certified



Removable safety guard in stainless steel. Not CE-certified

**OPTIONS – ATTACHMENT DRIVE**



Attachment drive for mean mincer and vegetable cutter



Meat mincer, 70 mm



Meat mincer, 82 mm



Vegetable cutter GR20

**VARIMIXER AR80 STANDARD TOOLS – A-EQUIPMENT 80L**



Whip, hook, beater (aluminium food grade) and bowl 80 liter in stainless steel.

**VARIMIXER AR80 STANDARD TOOLS – B-EQUIPMENT 80/40L**



Whip, hook, beater (aluminium food grade) and bowl 80/40 liter in stainless steel.

**OPTION – TOOLS**



Wing whip, stainless steel



Whip with 1 mm thicker wires, stainless steel



Whip with thinner wires, stainless steel



Whip with reinforcement



Beater, stainless steel



Automatic scraper, stainless steel. Nylon or teflon blade. 80L and 80/40L.



Powder mixer, stainless steel



Tool rack, 127 cm

**EQUIPMENT**



Ring gas burner. Natural or liquid gas.



Bowl truck



Easylift 140



Flexlift Inox

### VARIMIXER AR80 STANDARD

White powder coated  
1 bowl 80 liter in stainless steel  
1 beater in aluminium (food grade)  
1 hook in stainless steel  
1 whip with stainless steel wires  
Fixed safety guard in plastic – CE-certified  
Digital timer and emergency stop  
Voltage: 3 ph, 400V, 50 Hz with 0 and ground. 2.900 W

### VARIMIXER AR80 STANDARD TECHNICAL DATA

Volume	80 l
Effect	2.900 W
Standard voltage*	400 V
Net weight	340 kg
H x W x L	1470x654x1150 mm
Variable speed	47 – 257 RPM
Phases	3 ph
IP code	IP32

\*Other voltage power supply are available upon request in the range of 100 to 480 V.  
All standard and marine mixers are available in 50 and 60 Hz.

### VARIMIXER AR80 MARINE VERSION

Stainless steel execution, water cover at air ventilation, slotted free screws, full welded stainless steel knees, gasket at the rear plate, gasket at front panel and top cover. Complies with USPHS.

Voltage: 3 ph, 440V, 50-60 Hz with 0 and ground. 2.900 W  
3 ph, 480V, 50-60 Hz with 0 and ground. 2.900 W

### DIMENSIONS

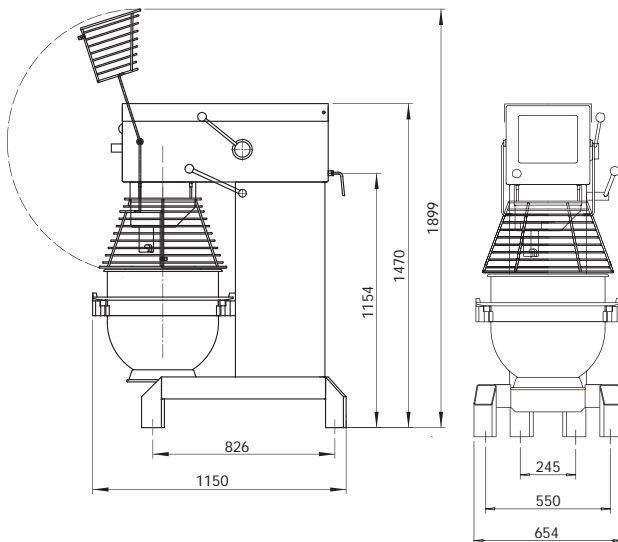

### CAPACITIES

Egg Whites	12 l
Whipped cream	30 l
Mayonnaise	64 l
Herb butter	60 kg
Mashed potatoes	50 kg
Bread dough (50% AR)	50 kg
Bread dough (60% AR)	60 kg
Ciabatta dough (70% AR)	60 kg
Muffins	48 kg
Layer cake base	20 kg
Meatball mix	60 kg
Icing	60 kg
Doughnut (50% AR)	50 kg

### CERTIFICATIONS



# Varimixer

A/S Wodschow & Co  
Kirkebjerg Søpark 6  
DK-2605 Brøndby  
P: +45 4344 2288  
E: info@varimixer.com  
www.varimixer.com