

OPERATING INSTRUCTIONS

AR30

AR40-AR40P

AR60-AR60P

VL-1



082013 ORDER NO.: 00313-VL-1 GB Original instructions

A/S Wodschow & Co.

Kirkebjerg Søpark 6
DK-2605 Brøndby

Phone: +45 43 44 22 88
info@wodschow.dk
www.bearvarimixer.dk

Denmark

CONTENTS:

GENERAL:	2
SAFETY:	2
INSTALLATION OF NEW MIXER:.....	2
CONSTRUCTION OF THE MIXER:.....	3
THE MAXIMUM CAPACITY OF THE MIXER:	3
RECOMMENDED MAXIMUM SPEEDS:.....	3
OPERATION OF THE MIXER:	4
START-UP AFTER STOP AT HIGH SPEED:	4
OVERLOAD:	4
CORRECT USE OF TOOLS:.....	5
CLEANING:	5
MAINTENANCE AND LUBRICATION:	5
GREASE TYPES:.....	5
LIST OF ERRORS AND POSSIBLE SOLUTIONS:	6
ADJUSTMENT OF SPECIAL V-BELT:.....	6
ADJUSTMENT OF SPEED:	6
ADJUSTMENT OF BOWL FIXING:.....	7
ADJUSTMENT OF BOWL CENTERING:	7
ADJUSTMENT OF BOWL HEIGHT:.....	7
ERROR CODES:.....	8
ELECTRICAL DIAGRAMMES:	9

OBS:

The mixer is to be connected to power via a plug. The plug must be dimensioned for min. 16 A, 230/400V~, IP44

When connecting;

- 1 phase with 0 + earth, use 3 pole plug
- 2 phases + earth, use 3 pole plug
- 3 phases + earth, use 4 pole plug
- 3 phases with 0 + earth, use 5 pole plug

GENERAL:

In case of complaints, please contact your supplier.

The guarantee does not cover faults resulting from faulty operation, overloading and lacking observance of directions of maintenance.

It should be checked that all loose parts are delivered with the mixer such as bowl, tools, grease gun and rubber feet

If the mixer has an attachment drive only equipment produced by **A/S WODSCHOW & CO.** must be connected.

SAFETY:

The constant noise level of the workplace of the operator is lower than 70 dB (A)



The mixer is designed for manufacture of products which do not during processing cause reactions or emit substances which may be detrimental to the user.



Putting your fingers in the bowl while the mixer is running may cause injuries.

INSTALLATION OF NEW MIXER:



Never lift the mixer by the handle for speed adjustment or by the handle for bowl lift.

Installation and securing:

The mixer must be mounted with rubber feet, which neutralize both shaking and rusting. Spacers can be inserted under the mixer's feet, if the floor is not completely even.

The mixer is placed directly on the floor. Foundation bolts in the floor are only necessary under special conditions, e.g. on ships.

Connection to power:

Before the mixer is connected to power, it should be checked that the voltage and frequency printed on the machine label is correct in relation to the place of installation. The machine label is placed at the top right side of the mixer.

Checking of the direction of rotation of the planetary head:



Lift up the bowl arms to normal working position and start the mixer without bowl and tools. Check the direction of rotation of the planetary head: the planetary head must rotate in the direction as stated by the arrow above the planetary head. If the direction of rotation is wrong, 2 of the phase wires of the connecting cable must be inverted.

CONSTRUCTION OF THE MIXER:

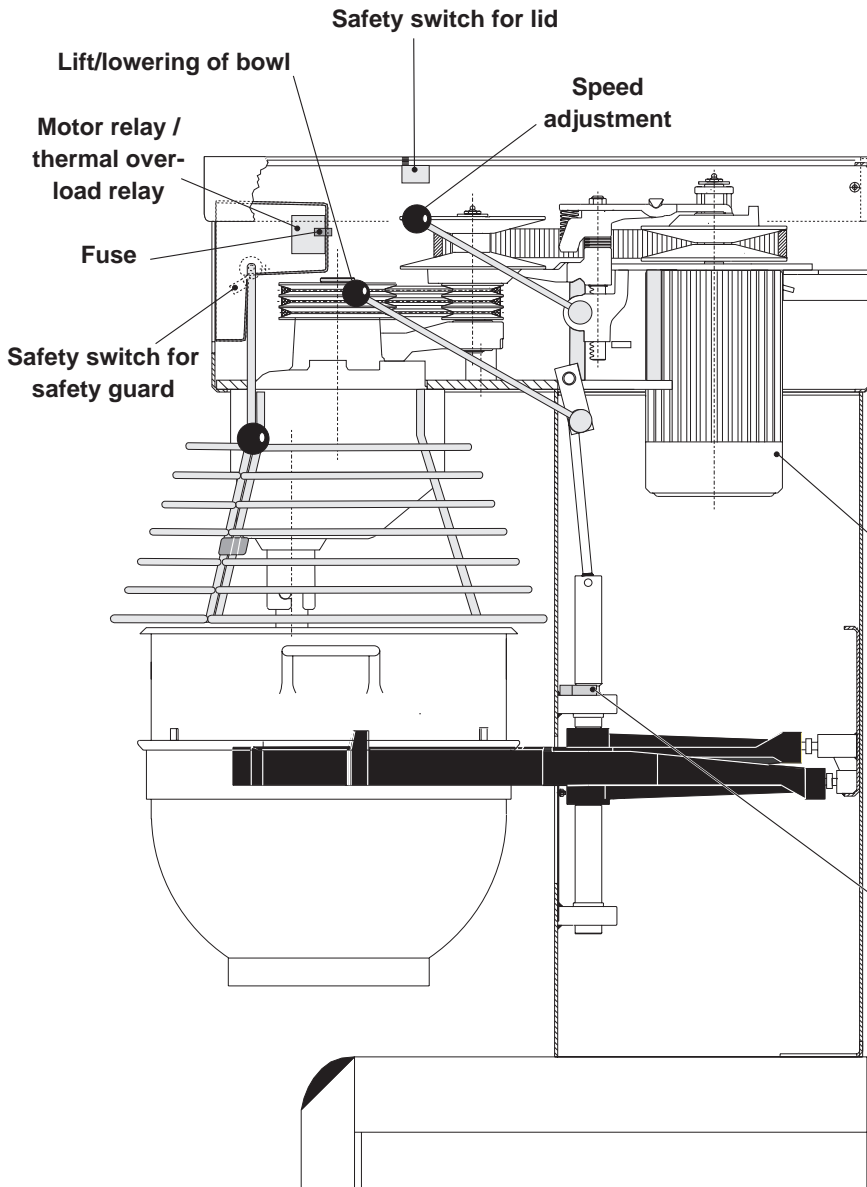

RECOMMENDED MAXIMUM SPEEDS:

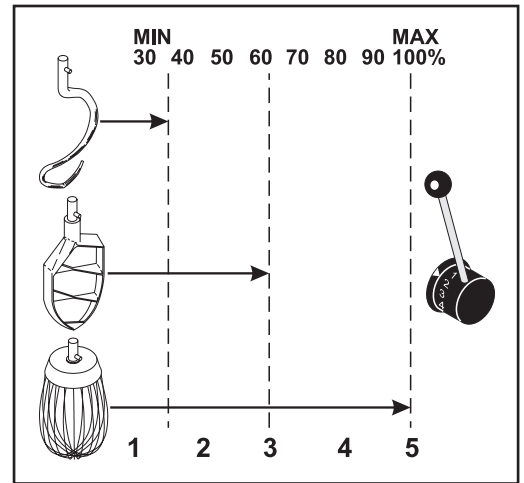

Size of mixer	Motor
AR30	1,0 kw
AR40	1,1 kw
AR40P	1,85 kw
AR60	1,85 kw
AR60P	3,0 kw

THE MAXIMUM CAPACITY OF THE MIXER:

Capacities per mix	Tool	AR30	AR40	AR40P	AR60	AR60P
Egg white	Whip	3,5 L	6 L	6 L	9 L	9 L
Whipped cream	Whip	7,5 L	10 L	10 L	15 L	15 L
Mayonnaise *	Whip	24 L	32 L	32 L	48 L	48 L
Herb butter	Beater	17 kg	25 kg	25 kg	45 kg	45 kg
Mashed potatoes *	Beater / Whip	18 kg	23 kg	23 kg	36 kg	36 kg
Bread dough (50%AR) **	Hook	16 kg	22 kg	32 kg	34 kg	46 kg
Bread dough (60%AR)	Hook	22 kg	30 kg	34 kg	44 kg	56 kg
Ciabatta dough * (70%AR)	Hook	22 kg	30 kg	34 kg	40 kg	50 kg
Muffins *	Beater	18 kg	24 kg	24 kg	33 kg	33 kg
Layer cake base	Whip	7 kg	10 kg	10 kg	15 kg	15 kg
Meatball mix *	Beater	25 kg	30 kg	30 kg	45 kg	45 kg
Icing	Beater	20 kg	29 kg	29 kg	40 kg	40 kg
Doughnut (50%AR)	Hook	18 kg	25 kg	36 kg	36 kg	54 kg

AR = Absorption Ratio (%AR)
(Liquid in % of solids)

Example: A basic recipe contains 1 kg of solids and 0,6 kg of liquid:

$$\text{This gives AR} = \frac{0,6 \text{ kgs} \times 100}{1 \text{ kg}} = 60\%$$

If for instance it is required to use the maximum capacity of the mixer, the calculated AR = 60% is used for determining the amount of solids and liquid in the dough:

If a 30 L mixer is used, and a dough with AR = 60% is to be kneaded, the maximum capacity is = 22 kg. Now the weight of solids in this dough is calculated:

$$\text{Solids} = \frac{\text{Max. capacity} \times 100}{\text{AR} + 100} = \frac{22 \text{ kg} \times 100}{60 + 100} = 13,75 \text{ kg}$$



$$\text{Weight of liquid} = 22 \text{ kg} - 13,75 \text{ kg} = 8,25 \text{ kg}$$

* Scraper recommended

** Low speed operation is recommended

Local variations in the characteristics of the ingredients can influence water absorption, volume and baking characteristics, etc.

OPERATION OF THE MIXER:

- A) Open the safety guard and place the bowl in the bowl arms. **OBS:** The bowl arms must be in lowest position and the bowl must be pushed all the way into the bowl arms. The bowl's "centre ear" must be turned in towards the mixer (**fig.2 and fig.3**).
- B) Place the mixing tool in the bayonet shaft. The pin on the tool must be turned into the bayonet hole (**fig.2**).
- C) Raise the bowl to working position by turning the handle for bowl lift in the direction of the arrow (**fig.2**), ensure that the bowl is placed correctly. Close the safety guard.
- D) The mixing time can be set on the timer using the  and  buttons. The mixer stops automatically when the mixing time has run out. (If the mixer stops at high speed when the mixing time runs out, follow the instructions "**Start-up after stop at high speed**" before starting the mixer again).
- E) Start the mixer by pressing  (**fig.1**)
- F) Turn the speed selector lever (**fig. 4**) to the rear until the required speed has been obtained, (notice the recommended maximum speeds on page 3).



The speed must be changed only when the mixer is running.

The mixer must not be started when loaded in high speed position.

- G) Before the mixer is stopped, the speed selector lever must be moved back to lowest speed (**fig.4**).
- H) Stop the mixer by pressing  (**fig.1**)

START-UP AFTER STOP AT HIGH SPEED:

This procedure is used in all cases where the mixer has been interrupted at high speed, either because the mixer has been stopped using , the mixing time has run out, the emergency stop is activated or the safety guard is opened:

- 1) Lower the bowl and remove the tool from the bayonet.
- 2) Raise the bowl arms, either empty or with the bowl.
- 3) Close the safety guard, start the mixer and move the speed selector lever back to lowest speed.
- 4) Switch off the mixer. Now the mixer can be started as usual.

OVERLOAD:



Do not overload the mixer. Sticky and heavy doughs can overload the mixer. Overloading is further exacerbated if the speed of the mixing tool is increased beyond the recommended values or if a wrong mixing tool is used. Large lumps of fat or cooled ingredients must be cut into small parts before they are placed in the bowl.

Longer time overload will interrupt the mixer.



***OH** will be written in the mixer's display. After a short while the display will change back to normal mode and you can start the mixer again as described in "**Start-up after stop at high speed**".*

Fig. 1 Operation panel.

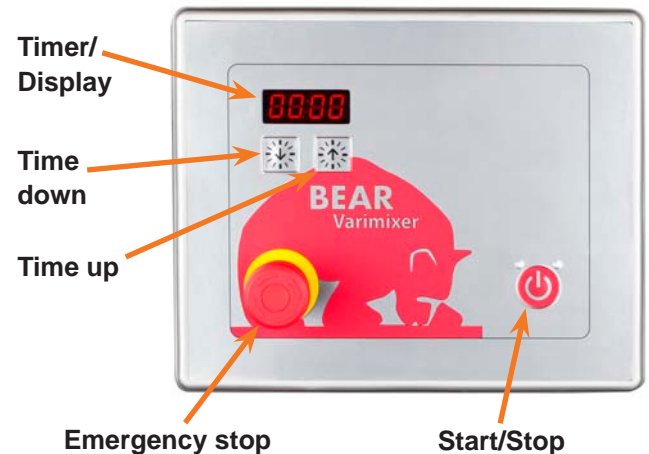

Fig. 2

Mixer with open safety guard, lowered bowl and mounted tool.

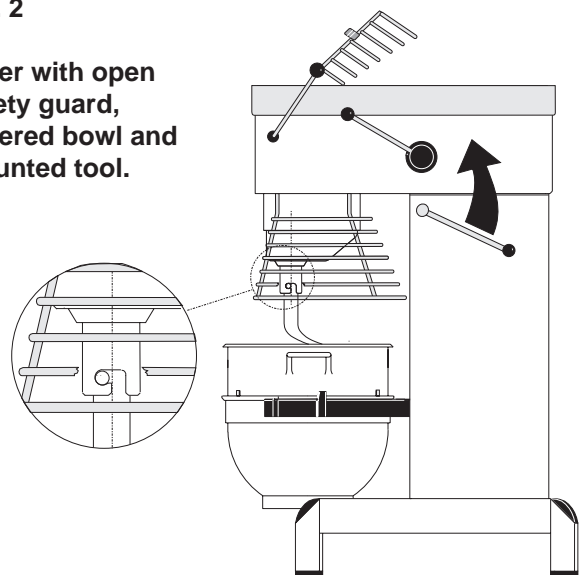

Fig. 3

Mixer seen from above, the bowl has been pushed all the way into the bowl arms. **Notice: the centre "ear" of the bowl is facing the mixer**

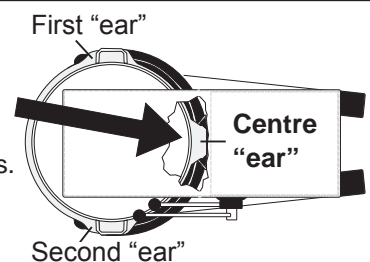
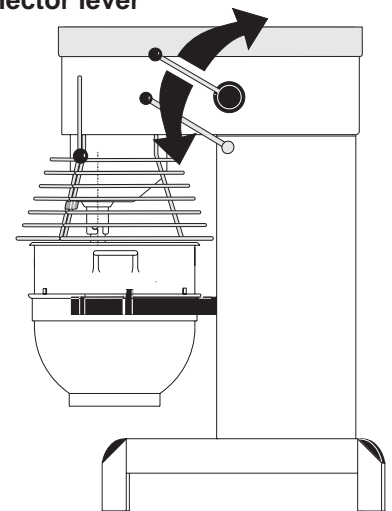

Fig. 4 Speed selector lever



CORRECT USE OF TOOLS:



The meat mincer must not be used for production of bread crumbs as this will cause unnecessary wear and tear on some mixer parts.



Whips should not be struck against hard objects as e.g. the edge of the bowl. This will make the life of the tool shorter due to increasing deformity.

Recommended applications for tools:

Whip	Beater	Hook
Cream	Cake dough	Bread dough
Egg whites	Butter cream	Dark bread
Mayonnaise and the like	Waffle dough	and the like
	Minced meat and the like	



For production of mashed potatoes the special wing whip or the whip with thicker wires should be used, alternatively use the beater and the whip.

CLEANING:

The mixer should be cleaned daily or after use. The mixer should be cleaned with a soft cloth and clean water. Sulphonated soaps should be used with caution as they destroy the mixer's lubricants.



Never use high pressure cleaning for the mixer.

Parts made of aluminum should not be used to strongly acidic, highly alkaline or highly salty foodstuffs, which may attack aluminum without coating.

Tools of aluminium must not be washed with strong alkaline detergents (pH between 5 and 8).

The soap suppliers can recommend the correct type of soap.



Please note that the plastic safety guard can be damaged if exposed to high temperatures for a considerable period. (Max. temperature 65°C)

Cleaning of attachment drive: after use of the attachment drive this should be wiped inside with a soft cloth.

MAINTENANCE AND LUBRICATION:

The infinitely variable gear must be lubricated regularly, i.e. a lubrication interval of approx. 60 hours of operation.

Lubrication of infinitely variable gear:

OBS. Special grease !!(Use the grease gun delivered together with the mixer). Start the mixer and increase the speed to approx. 50%. Stop the mixer (use the emergency stop) and open the lid on the top of the mixer. On the top of each of the two pulley set shafts is a grease nipple (fig. 5 point 1). Press grease through the grease nipples

until the grease gun feels hard to press or until grease comes out between the shaft and the pulleys.



The mixer must not be started until the screws which hold the lid are inserted.

Start the mixer, and set the speed back to low speed.

Stop the mixer and fill the grease gun with new grease so that it is ready for next time.

Lubrication of other movable parts:

The movable parts of the bowl arms, the shaft and the lifting rod must also be lubricated with oil. Remove the rear covering and lubricate the marked points with an oil can. (fig.5 pkt.2)

GREASE TYPES:

Grease for the pulley set shafts: **Castrol LMX.**

On repair of the planetary head: Grease the toothed wheel and the toothed rim with **Molub Alloy 936SF Heavy** or **Castrol Grippa 355**, the needle bearings in the planetary head must not be lubricated with this type of grease. Do not use any another type of grease than the one stated here.

On repair of the attachment drive: Fill the attachment drive with 0.35 L **ESSO Fibrax EP 370.**

fig.5 Greasing of infinitely variable gear and other movable parts:

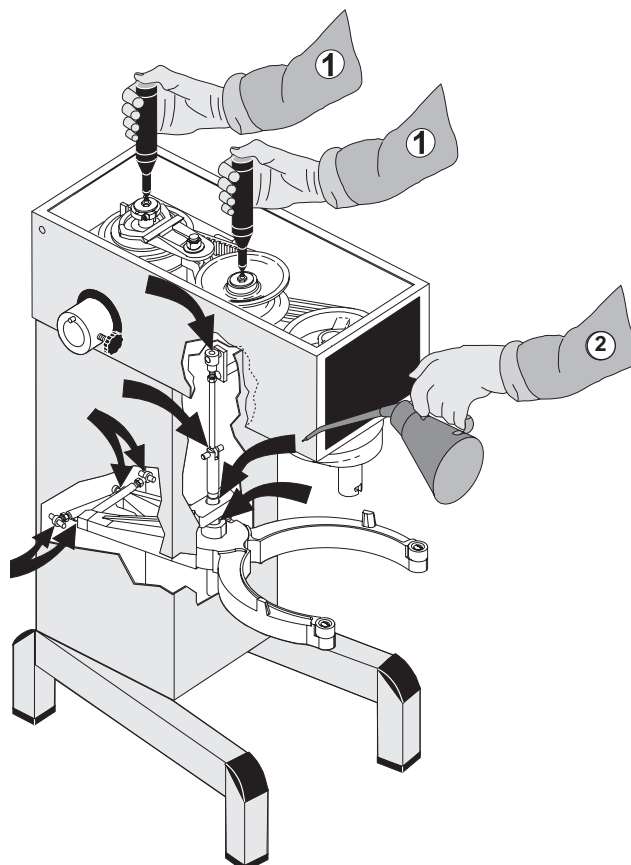

LIST OF ERRORS: In case of other errors, contact the supplier. **POSSIBLE SOLUTION:**

A rattling sound from the closed part of the mixer.

Adjustment of special v-belt

The mixer starts "striking" when kneading dough which normally causes no problems.

Adjustment of special v-belt

The mixer changes its speed by itself.

Adjustment of special v-belt

The minimum and the maximum speeds are changing.

Adjustment of speed.

The bowl is too tight or too loose.

Adjustment of bowl fixing

The tool hits the sides of the bowl.

Adjustment of bowl centering

The tool hits the bottom of the bowl.

Adjustment of bowl height



Prior to a possible repair or adjustment, switch off the mixer by disconnecting the power cable.

ADJUSTMENT OF SPECIAL V-BELT:

The distance **(X)** is only indicative as it depends on the tolerance of the special V-belt.

1. Start by tightening the v-belts (*).
2. Tighten the special V-belt **(A)** by moving one or two washers from **(V)** to **(T)**.
3. Start the mixer and leave it running while the nut **(U)** is tightened. Do not tighten it too much.
4. On the front pulley set the stud **(E)** on the varispeed collar **(F)** must be placed inside the lower fork **(G)** and on the rear pulley set outside the fork for belt tightener **(B)**, (both must point backwards).
5. Tolerances in the transmission might cause that the special V-belt **(A)** is hitting the pins of the pulley sets when the speed has been adjusted. In such cases the distance **(X)** must be reduced.
6. Then follow the section: "Adjustment of speed"

ADJUSTMENT OF SPEED:

1. The stop screws **(J)** on the speed lever should be adjusted so that the measurement **(H)** is 1-2 mm on the front and the rear pulley, at low and high speed, respectively. Tighten the counter nuts **(K)** when the speed is correctly adjusted.
2. Tolerances in the transmission might cause that the special V-belt **(A)** is hitting the pins of the pulley sets **(Z)** when the speed has been adjusted. In such cases the distance **(X)** must be reduced, see "Adjustment of special v-belt", and the speed must be readjusted.

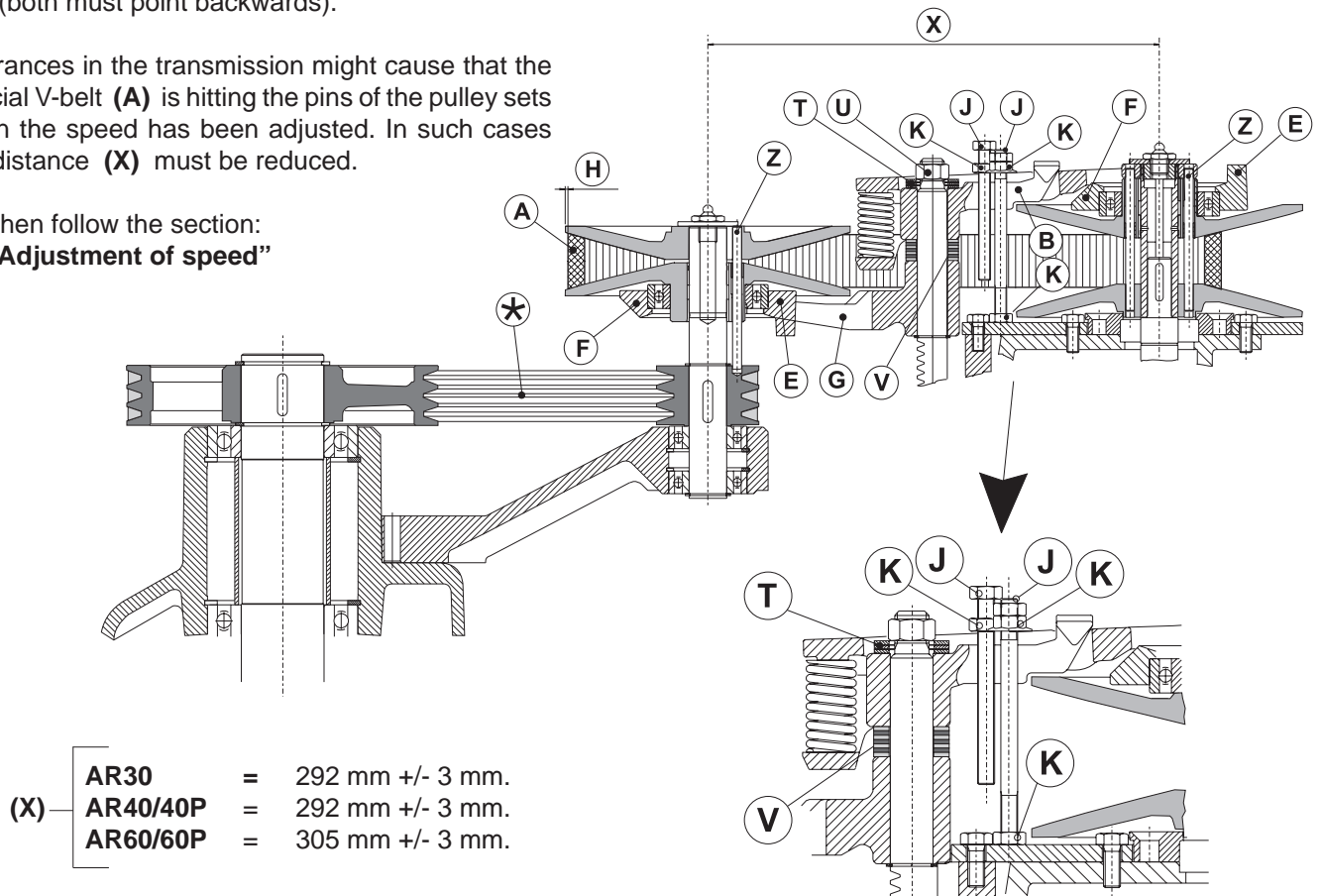

ADJUSTMENT OF BOWL FIXING:

The bowl arms must be raised to normal working position. Loosen the counter nuts (1) (fig. 6) and remove the cotter pins (2). Turn the bolts (3) until correct fixing of the bowl is achieved. By turning the bolts **out** of the extension tube the fixing is increased. Start by turning one of the bolts half a revolution.

The adjusting diameter shall be measured inside between the bowl arms:

Adjusting diameter:	AR30	=	361,8mm
	AR40	=	391,3mm
	AR60	=	450,4mm

ADJUSTMENT OF BOWL CENTERING:

Loosen the counter nuts (1) (fig. 6) and remove the cotter pins (2). Turn the bolts (3) until the bowl is in the centre of the mixer. In order not to alter the fixing of the bowl, one of the bolts must be turned **out** of the extension tube and the other **into** the extension tube. Use the flat beater to check that the bowl is correctly centred and turn the planetary head with your hand before the voltage is connected.

fig.6 Adjustment of bowl fixing and bowl centering

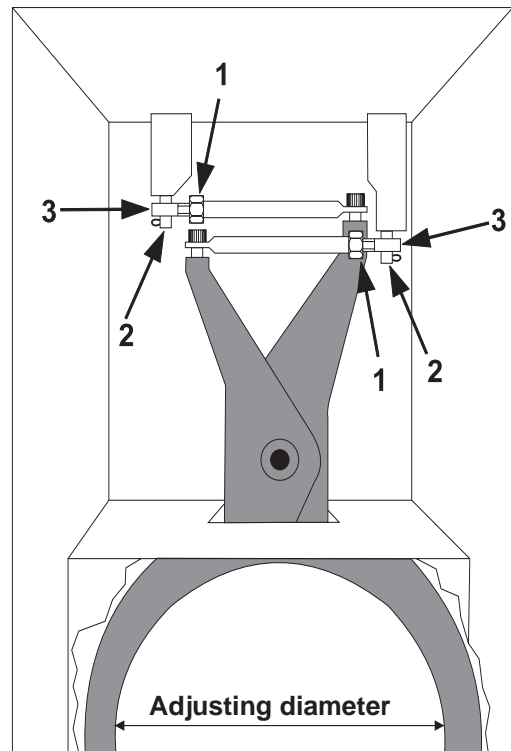

ADJUSTMENT OF BOWL HEIGHT:

The distance (X) is measured from the bottom side of the bayonet hole to the surface on the bowl arms on which the bowl rests (fig.7a). The bowl arms must be lifted to normal working position.

(X):	AR30	=	162 mm.
	AR40	=	162 mm.
	AR60	=	178 mm.

Lower the bowl arms down on a wooden block so that the weight of the bowl arms are not loading the lifting system. Loosen the counter nut (1), (fig.7b). Take out the cotter pin (2). Take out the lifting rod (3). The lifting bolt (4) is now loose and can be turned out or into the lifting nut (5), until the correct height of the bowl arms has been reached.

fig.7b Adjustment of bowl height:

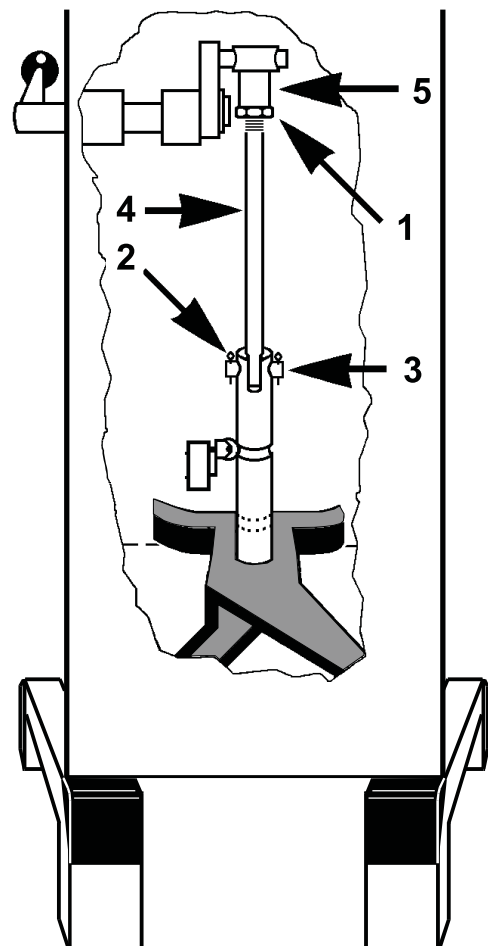
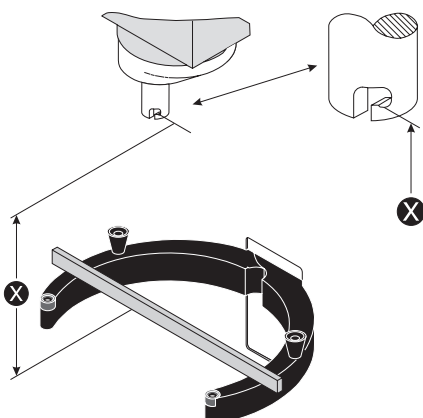

fig.7a Measuring of bowl height:



ERROR CODES:

If the mixer is overloaded, the motor will stop and  will be shown for 'overheat' in the display.

- Allow the mixer to cool down.
- After a short time, the display will change to normal mode.
- The mixer can be started again. See also the section **“Start-up after stop at high speed”** on page 4.

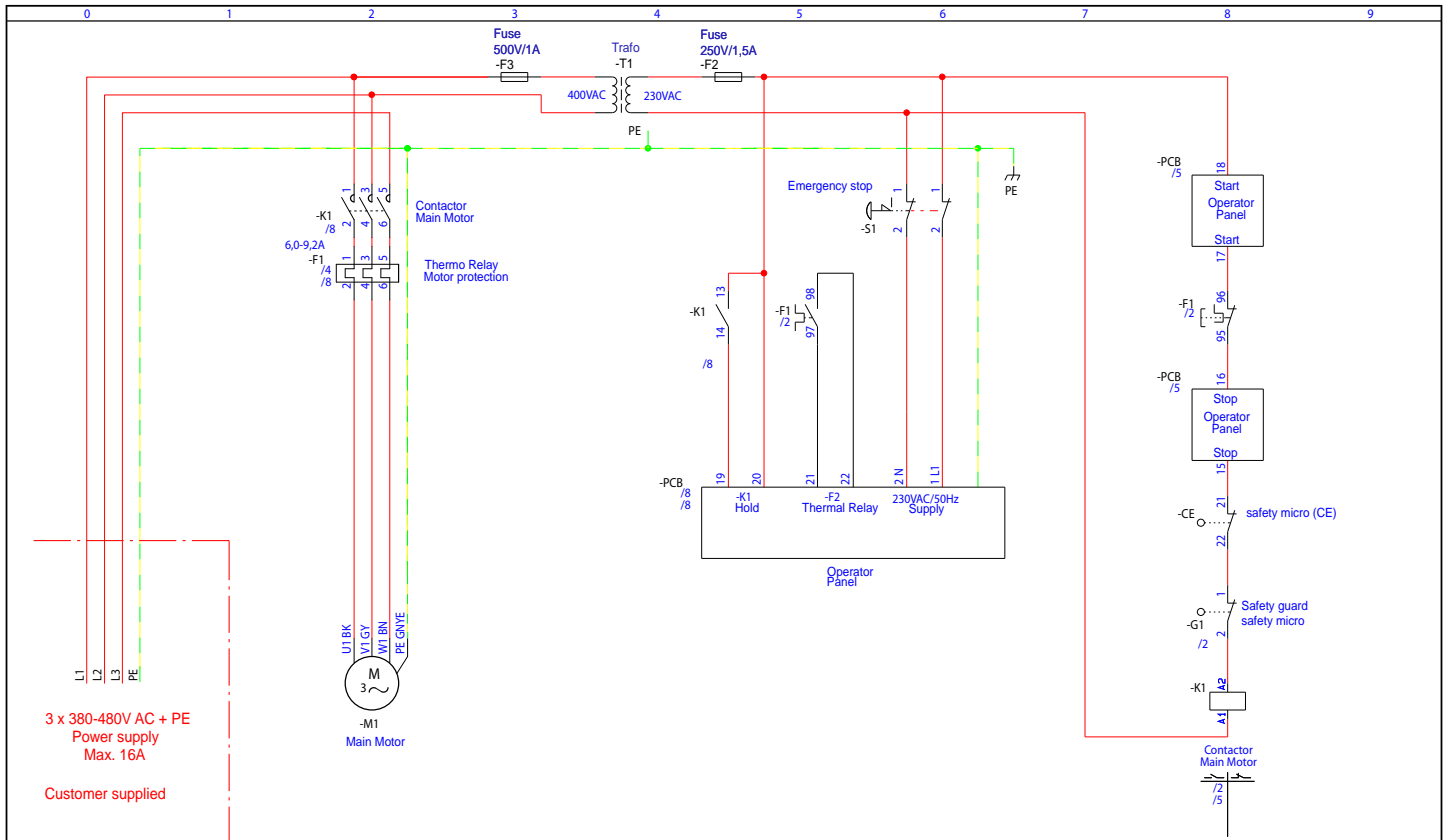

3 x 380-480V AC + PE
Power supply
Max. 16A
Customer supplied

<p>A/S WODSCHOW & CO Industrisvinget 6 DK-2605 Broenby www.bearvarmixer.dk</p>	<p>Project title: VL1, 3 x 380 - 480V AC + PE Page title: Main Power</p>	<p>Subject name:</p>	<p>Project rev.:</p>	<p>Page 1</p>
	<p>File name: VL1-3P-PE</p>	<p>Drawing no.:</p>	<p>Page rev.:</p>	<p>Previous page</p>
	<p>Const. (project/page): /</p>	<p>Const. (project/page): /</p>	<p>Last printed: 10-06-2011</p>	<p>Next page</p>
	<p>Appr. (init/date): /</p>	<p>Appr. (init/date): /</p>	<p>Last corrected: 10-06-2011</p>	<p>Number of pages: 1</p>

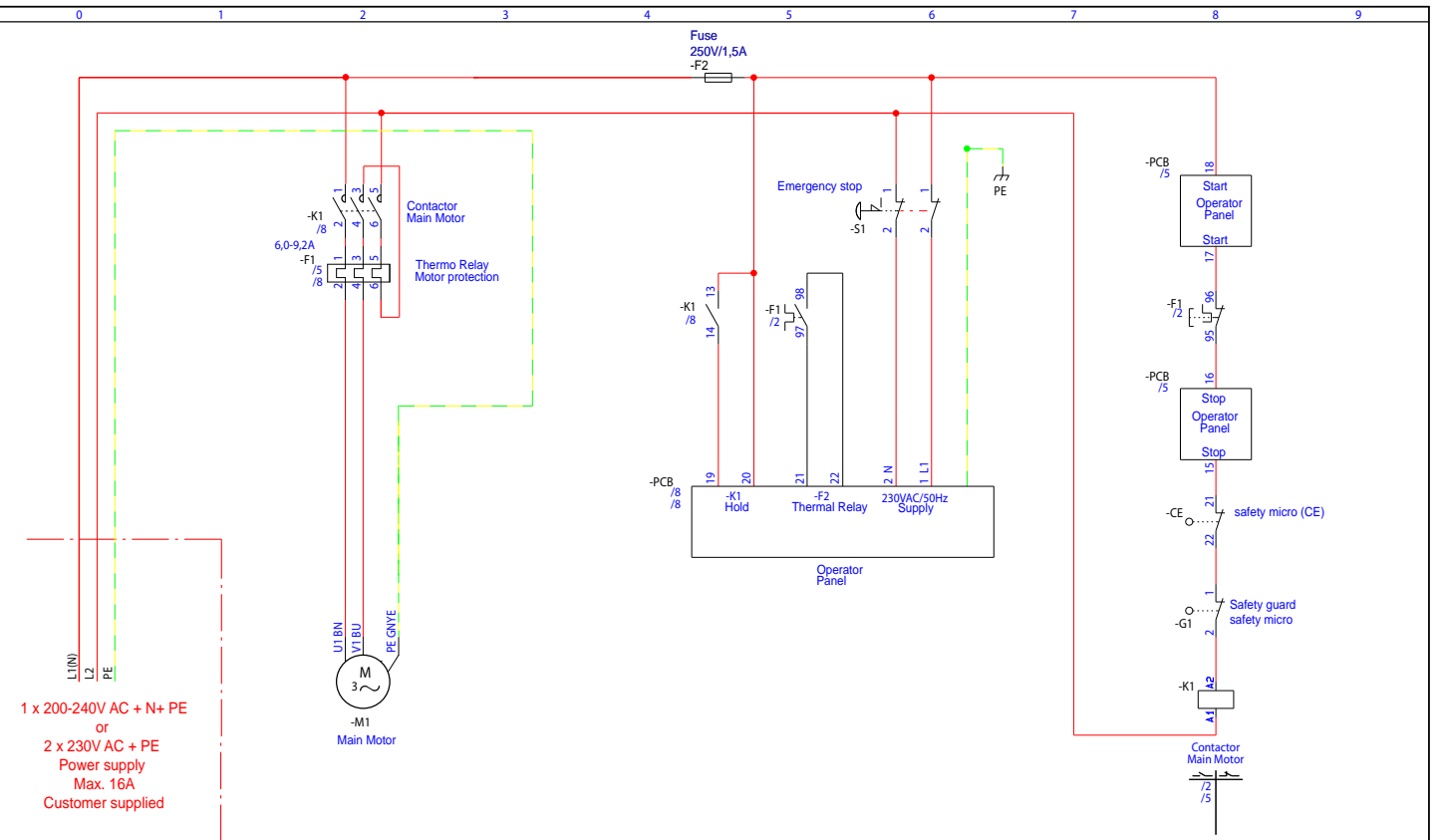

1 x 200-240V AC + N+ PE
or
2 x 230V AC + PE
Power supply
Max. 16A
Customer supplied

<p>A/S WODSCHOW & CO Industrisvinget 6 DK-2605 Broenby www.bearvarmixer.dk</p>	<p>Project title: VL1, 3 x 200 - 240V AC + N+ PE or 2x230V AC + PE Page title: Main Power</p>	<p>Subject name:</p>	<p>Project rev.:</p>	<p>Page 1</p>
	<p>File name: VL1-1P-N-PE OR 2P+PE</p>	<p>Drawing no.:</p>	<p>Page rev.:</p>	<p>Previous page</p>
	<p>Const. (project/page): /</p>	<p>Const. (project/page): /</p>	<p>Last printed: 10-06-2011</p>	<p>Next page</p>
	<p>Appr. (init/date): /</p>	<p>Appr. (init/date): /</p>	<p>Last corrected: 10-06-2011</p>	<p>Number of pages: 1</p>

Indhold af CE Overensstemmelseserklæring, (Maskindirektivet, 2006/42/EC, Bilag II, del A)	DK
Contents of the EC Declaration of conformity for machinery, (Machinery Directive 2006/42/EC, Annex II., sub. A)	GB
Inhalt der EG-Konformitätserklärung für Maschinen, (Richtlinie 2006/42/EG, Anhang II, sub A)	DE
Contenu de la Déclaration CE de conformité d'une machine, (Directive Machine 2006/42/CE, Annexe II.A)	FR
Inhoud van de EG-verklaring van overeenstemming voor machines, (Richtlijn 2006/42/EC, Bijlage II, onder A)	NL
Contenido de la declaración "CE" de conformidad sobre máquinas, (Directiva 2006/42/EC, Anexo II, sub A)	ES

Fabrikant; Manufacturer; Hersteller; Fabricant; Fabrikant; Fabricante: A/S Wodschow & Co.
 Adresse; Address; Adresse; Adresse; Adres; Dirección: Kirkebjerg Søpark 6, DK-2605 Brøndby, Denmark

Navn og adresse på den person, som er bemyndiget til at udarbejde teknisk dossier
 Name and address of the person authorised to compile the technical file
 Name und Anschrift der Person, die bevollmächtigt ist, die technischen Unterlagen zusammenzustellen
 Nom et adresse de la personne autorisée à constituer le dossier technique
 naam en adres van degene die gemachtigd is het technisch dossier samen te stellen
 nombre y dirección de la persona facultada para elaborar el expediente técnico

Navn; Name; Name; Nom; Naam; Nombre: Kim Jensen
 Adresse; Address; Adresse; Adresse; Adres; Dirección: Kirkebjerg Søpark 6, DK-2605 Brøndby, Denmark
 Sted, dato; Place, date; Ort, Datum; Lieu, date; Plaats, datum; Place, Fecha: Brøndby, 15-12-2009

Erklærer hermed at denne røremaskine
 Herewith we declare that this planetary mixer
 Erklärt hiermit, dass diese Rührmaschine
 Déclare que le batteur-mélangeur ci-dessous
 Verklaart hiermede dat Menger
 Declaramos que el producto batidora

- er i overensstemmelse med relevante bestemmelser i Maskindirektivet (Direktiv 2006/42/EC)
 is in conformity with the relevant provisions of the Machinery Directive (2006/42/EC)
 konform ist mit den Bestimmungen der EG-Maschinenrichtlinie (Direktiv 2006/42/EG)
 Satisfait à l'ensemble des dispositions pertinentes de la Directive Machines (2006/42/CE)
 voldoet aan de bepalingen van de Machinerichtlijn (Richtlijn 2006/42/EC)
 corresponde a las exigencias básicas de la Directiva sobre Máquinas (Directiva 2006/42/EC)
- er i overensstemmelse med følgende andre CE-direktiver
 is in conformity with the provisions of the following other EC-Directives
 konform ist mit den Bestimmungen folgender weiterer EG-Richtlinien
 Est conforme aux dispositions des Directives Européennes suivantes
 voldoet aan de bepalingen van de volgende andere EG-richtlijnen
 está en conformidad con las exigencias de las siguientes directivas de la CE

2004/108/EC

Endvidere erklæres det
 And furthermore, we declare that
 Und dass
 Et déclare par ailleurs que
 En dat
 Además declaramos que

- at de følgende (dele af) harmoniserede standarder, er blevet anvendt
 the following (parts/clauses of) European harmonised standards have been used
 folgende harmonisierte Normen (oder Teile/Klauseln hieraus) zur Anwendung gelangten
 Les (parties/articles des) normes européennes harmonisées suivantes ont été utilisées
 de volgende (onderdelen/bepalingen van) geharmoniseerde normen/nationale normen zijn toegepast
 las siguientes normas armonizadas y normas nacionales (o partes de ellas) fueron aplicadas

EN454:2000 ; EN60204-1:2006; EN12100-1:2005

EN12100-2:2005; EN61000-6-1:2007; EN61000-6-3:2007

Innehåll i EG-försäkran om maskinens överensstämmelse, (Maskindirektivet 2006/42/EG, bilaga 2, A)
Contenuto della dichiarazione CE di conformità per macchine, (Direttiva 2006/42/CE, Allegato II, parte A)
Sisukord EÜ masina vastavusdeklaratsioon, (Masinadirektiiv 2006/42/EÜ, lisa II, punkt A)
Treść Deklaracja zgodności WE dla maszyn (Dyrektywa maszynowa 2006/42/WE, Załącznik II, pkt A)
Sisältö EY-vaatimustenmukaisuusvakuutus koneesta (Konedirektiivi 2006/42/EY, Liite II A)

SE
IT
EE
PL
FI

Tillverkare; Fabbricante; Tootja; Producent; Valmistaja:

A/S Wodschow & Co.

Adress; Indirizzo; Aadress; Adres; Osoite:

Kirkebjerg Søpark 6, DK-2605 Brøndby, Denmark

Namn och adress till den person som är behörig att ställa samman den tekniska dokumentationen:

Nome e indirizzo della persona autorizzata a costituire il fascicolo tecnico

Tehnilise kausta volitatud koostaja nimi ja aadress

Imię i nazwisko oraz adres osoby upoważnionej do przygotowania dokumentacji technicznej

Henkilön nimi ja osoite, joka on valtuutettu kokoamaan teknisen tiedoston

Namn; Nome e cognome; Nimi; Imię i nazwisko; Nimi:

Kim Jensen

Adress; Indirizzo; Aadress; Adres; Osoite:

Kirkebjerg Søpark 6, DK-2605 Brøndby, Denmark

Ort och datum; Luogo e data; Koht, kuupäev; Miejscowość, data; Paikka, aika:

Brøndby, 15-12-2009

Försäkrar härmed att denna blandningsmaskin

Con la presente si dichiara che questo mixer planetaria

Deklareerime käesolevaga, et Planetaarmikseri

Niniejszym oświadczamy, że mikser planetarny

vakuuttaa, että tämä mikseri tyyppi

- överensstämmer med tillämpliga bestämmelser i maskindirektivet (2006/42/EG)
is è conforme alle disposizioni della Direttiva Macchine (Direttiva 2006/42/CE)
vastab kehtivatele masinadirektiivi (2006/42/EÜ) nõuetele
spełnia wymagania odpowiednich przepisów dyrektywy maszynowej (2006/42/WE)
on konedirektiivin (2006/42/EY) asiaankuuluvien säännösten mukainen
- överensstämmer med bestämmelser i följande andra EG-direktiv
è conforme alle disposizioni delle seguenti altre direttive CE
vastab järgmise EÜ direktiivide nõuetele
spełnia wymagania przepisów innych dyrektyw WE
on seuraavien muiden EY-direktiivien säännösten mukainen

2004/108/EC

Vi försäkrar dessutom att

e che

Lisaks ülaltoodule deklareerime, et

Ponadto oświadczamy, że

ja lisäksi vakuuttaa, että

- följande (delar/paragrafer av) europeiska harmoniserade standarder har använts
sono state applicate le seguenti (parti/clausole di) norme armonizzate
kasutatud on järgmisi Euroopa harmoniseeritud standardeid (või nende osi/nõudeid)
zastosowano następujące części/klauzule zharmonizowanych norm europejskich
seuraavia eurooppalaisia yhdenmukaistettuja standardeja (tai niiden osia/kohtia) on sovellettu

EN454:2000 ; EN60204-1:2006; EN12100-1:2005

EN12100-2:2005; EN61000-6-1:2007; EN61000-6-3:2007

A/S WODSCHOW & CO.

Kirkebjerg Søpark 6
DK-2605 Brøndby
Denmark

Phone: 43 44 22 88
info@wodschow.dk
www.bearvarimixer.com