

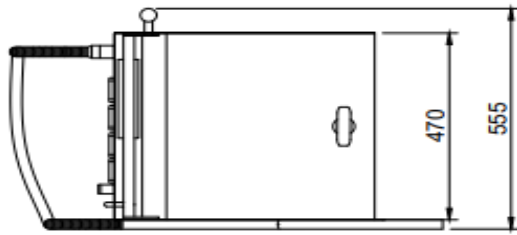

**INDUSTRY  
KITCHENS**

www.industrykitchens.com.au 1800 611 058



**TOP VIEW**

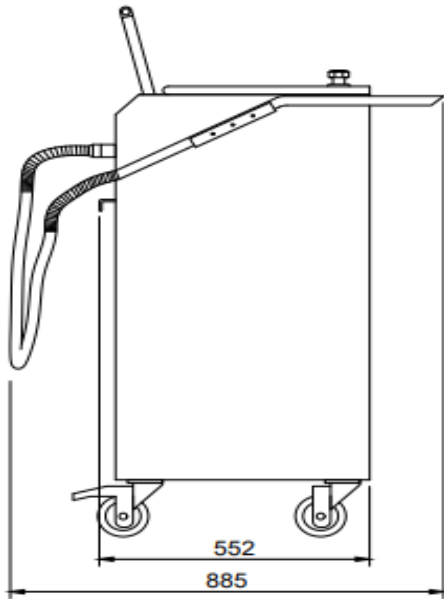

**SIDE VIEW**  
NTS

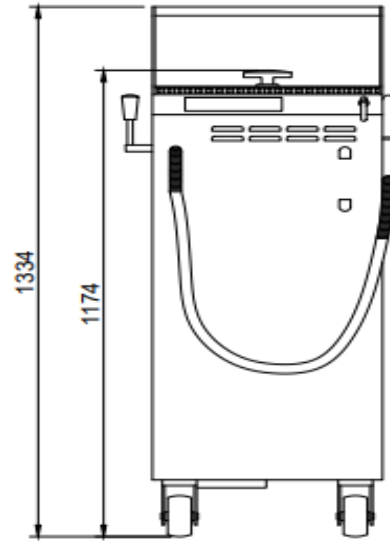

**FRONT VIEW**

**FEATURES INCLUDE:**

Normal usage	Ideal for catering industry and bakeries or high frying volume
Filtration power	up to 30 kg/min
Filtration efficiency	up to 5µm
Pumping Capacity	35kg/min
Tank Volume	.12 cubic m / 100kg
Particle uptake	10.7 kg
Weight	64kg
Temperature	Max. 200 degree Celcius
Material	Stainless steel 1.4301

The **VITO XL** cleans the oil, stores it in its .12 cubic meter (100 kg) tank and provides an easy and hygienic transport in the kitchen. Because of its innovative vacuum-filtration technology, particles remain in the filter in a dry condition. Like every VITO oil filter system the XL provides a microfiltration up to 5 µm. The unique design makes sure the XL can handle temperatures up to 200°C and provides highest safety at work, because of avoiding direct contact with the hot oil. After filtration the oil can easily be pumped back into the fryer automatically.

**Benefits:**

1. Increase the lifetime of your oil
2. Improves taste and Quality
3. Saves time and labor