

VITO XS

Spec sheet

INDUSTRY
KITCHENS

www.industrykitchens.com.au 1800 611 058

VITO[®]
oil filter system

Functionality:

VITO XS cleans your oil in an easy and hygienic way. It sucks the oil out of your fryer, cleans it from particles and stores it inside its 40l tank.

From there, it can be safely transported.

The oil can then either be pumped back into the deep fryer, or simply disposed.

Features:

- ♣ Operating temperature up to 200 °C
- ♣ Vacuum filtration
- ♣ Automatic off - VITO has built-in oillevel sensor
- ♣ Automatic safety off - filtration/return after 5min; heater after 30min
- ♣ Integrated heater (for solid fat additional system heater recommended)
- ♣ VITO made out of stainless steel (1.4301) and other food safe materials
- ♣ Hose can be removed by quick connector
- ♣ Filter basket is dishwasher-safe
- ♣ Adjustable height of the handle
- ♣ Lockable castors

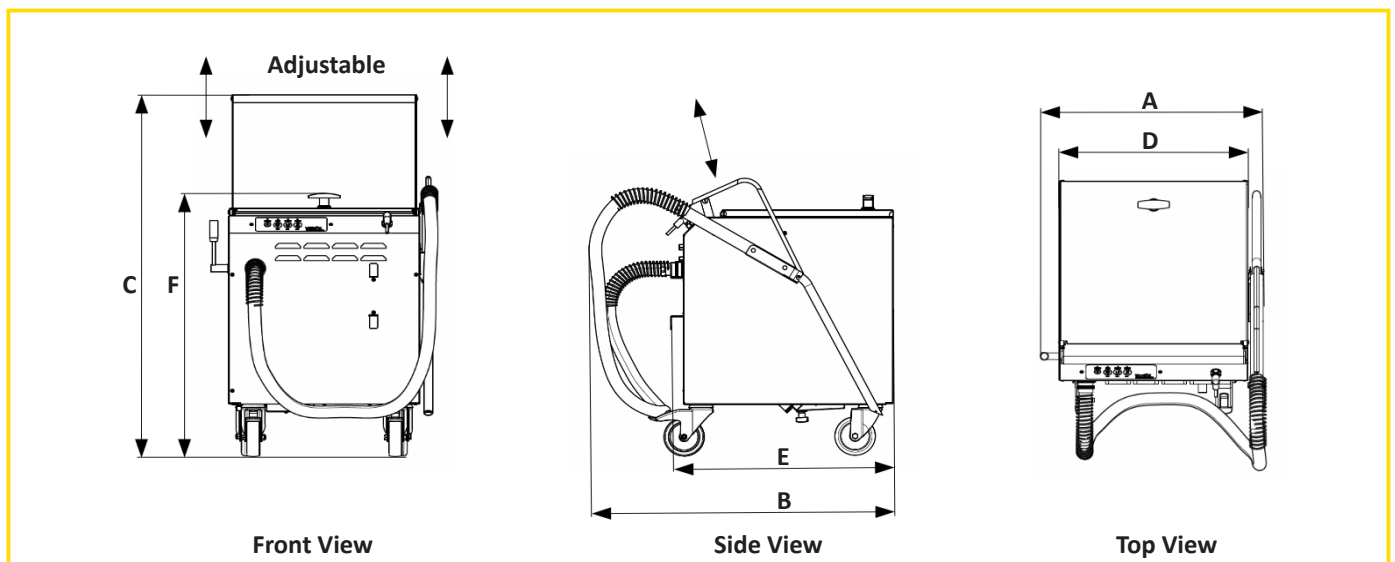

VITO XS technical Data:

	Width A	Depth B	Height C			Width D	Depth E	Height F
	555 mm	723 mm	843 mm			470 mm	552 mm	682 mm
Filtration power	Filtration efficiency	Particle capacity	Pumping power	Heating power	Max. power	Power connection	Fuse inside	Protection
up to 30 l/min	5 µm effective/ 20 µm nominal	10 l/10,7 kg*	35 l/min	110 W	1200 W	220 - 240 V, single phase	8 AT	Protection Earth (PE)
Tank	Weight	Temperature	Material					
40 l	45 kg	max. 200 °C	Stainless steel 1.4301					

*regular bread crumbs

Accessories:

- ♣ Additional system heater for solid fat (130 W)
- ♣ Data reader for usage control
- ♣ Various particle filters