

UF1300SDF-NR

INDUSTRY
KITCHENS

www.industrykitchens.com.au 1800 611 058

BROMIC
REFRIGERATION

Upright Freezer 1300L - 2 Doors - Stainless Steel

| Vertical Display & Storage



Upright Freezer 1300L - 2 Doors - Stainless Steel

| Vertical Display & Storage

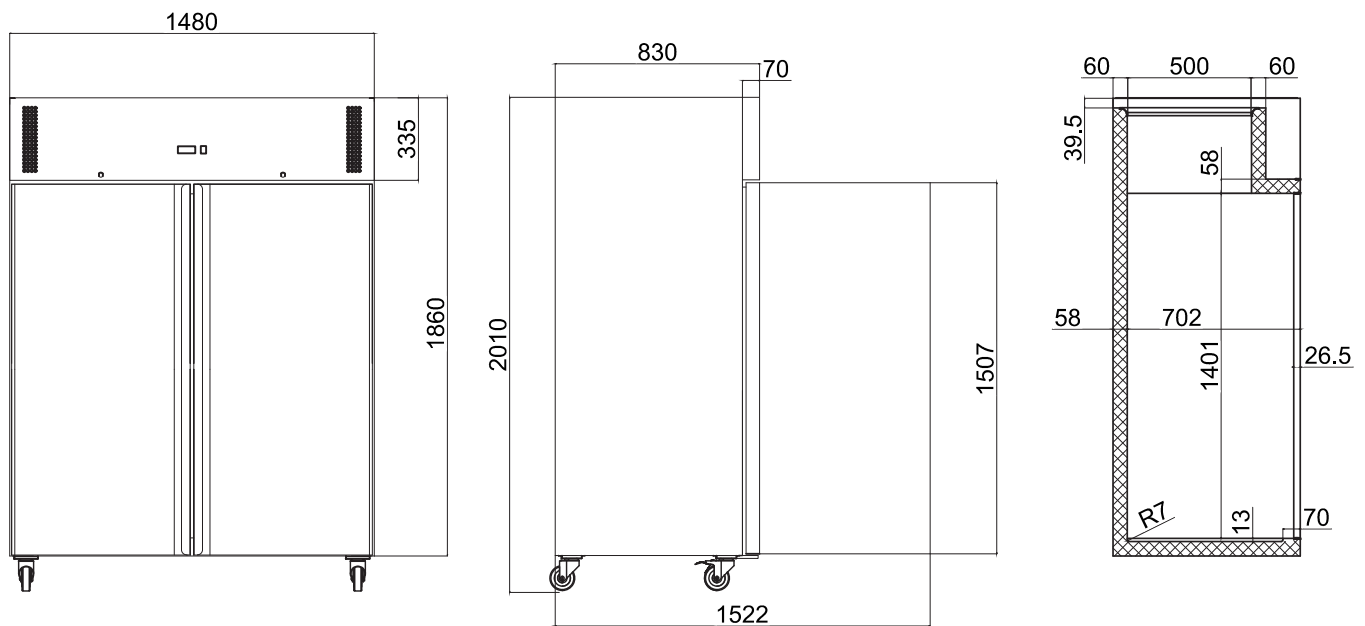

SPECIFICATIONS

Model Number	UF1300SDF-NR
Part Number	3735194-NR
Volume	1300L
Unit Weight	226kg
Packaged Weight	231kg
Adjustable Temp. Range	-22 to -18°C
Max. Ambient Temp.	38°C
Climate Class	4L1
Energy Consumption	13.617kWh/24h
GEMS Star Rating	3 stars
Refrigeration Capacity	800W
Air Circulation	Fan Forced
Refrigerant	R290
Rated Current	6A
Electrical Voltage	220-240V
Frequency	50Hz
Power Supply	Single Phase
Power Plug	1 x 10A
Plug Location	Rear, top left

Colour	Stainless Steel
Display Light Box	No
Internal Light	LED
No. of Doors	2
Door Type	Solid
Door Style	Hinged
Door Shape	Flat
Door Swing Dimension	830mm
Total Depth of door open	1520mm
Self-Closing Door	Yes
Door Lock	Yes
No. of Shelves incl Base	6
Shelf Type	Adjustable
Shelves Dimensions	530(w) x 650(d) mm
Temp. Controller	Digital
Castors	Yes
Warranty	2 Years Bromic Extra Care Warranty - Labour and Parts

DIMENSIONS

	External (mm)
Width	1480
Depth	830
Height	2010
	Internal (mm)
Width	1360
Depth	685
Height	1390
	Packaged (mm)
Width	1510
Depth	855
Height	2062