

## Two Door Glass Chiller (Remote)

Range: BackBar

SKOPE ID: GC402

Dimensions: 1585 mm (W) × 590 mm (D) × 870 mm (H)\*

Capacity: 290 L

\* Height with legs is adjustable from 855 to 890.

Project: \_\_\_\_\_

Item #: \_\_\_\_\_

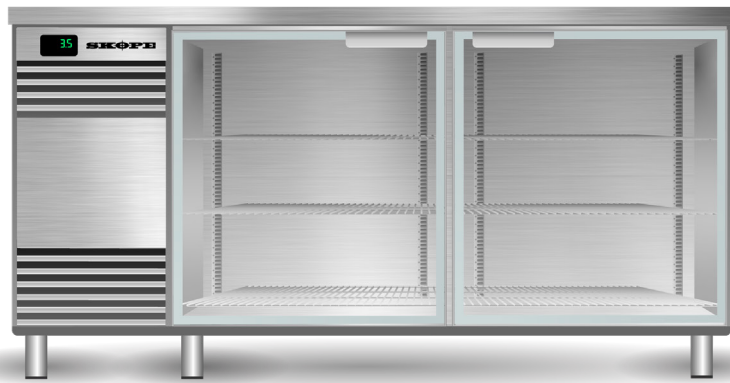

A 2-door under-bar glass chiller designed to keep your bar glasses cool and easily accessible to service staff in busy bars, clubs, and hotels. With a sleek aesthetic, including frameless glass doors, you can create an integrated look for all under-counter glass door bar refrigeration alongside SKOPE's BackBar range. The body is made from powder-coated, galvanised steel with colour options; it can also be upgraded to full stainless steel construction. The cabinet features wire shelving that can accommodate glass racks at either 355 mm × 430 mm, or 430 mm × 430 mm, for keeping your glasses chilled. The glass doors are designed for condensation protection in standard operating environments via the double-glazed, argon-filled, low-e, insulated panels. The glass chiller is a remote version, with self-contained R290 natural refrigerant also available. The fridge is certified to all Australian and New Zealand refrigeration and electrical safety standards.



Warranty



Natural Refrigerant

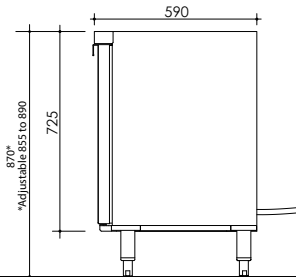
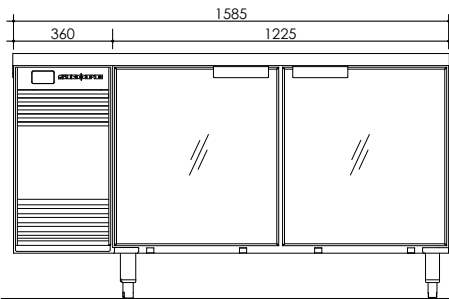
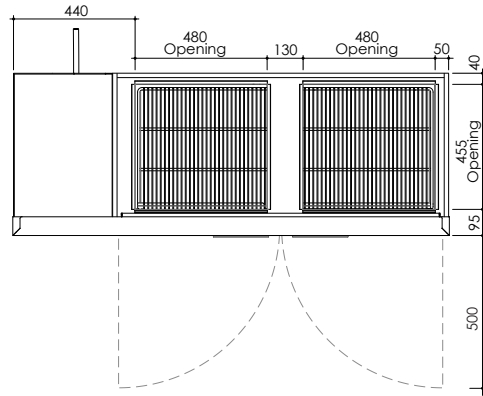

**Ground Clearance**  
 Leg (standard): 130 to 165 mm  
 Castor (optional): 95 to 115 mm  
 Plinth (optional): 0 mm

### Cabinet

<b>Type</b>	Glass Chiller		
<b>Finish</b>	Powder-coated galvanised steel or stainless steel		
<b>Insulation</b>	Type	PU foam	
	Thickness (mm)	50	
	Blowing Agent	Cyclo-iso pentane (C5H10/C5H12)	
<b>Doors</b>	Type	Glass swing door (double-glazed, low-e, argon-filled, tab-locking)	
	Opening Size	Height (mm)	535
		Width (mm)	510
<b>Top Opening</b>	Depth (mm)	455	
	Width (mm)	480	
<b>Shelving</b>	Four powder-coated wire shelves 4 x adjustable height shelf (495W x 440D)		
<b>Lighting</b>	Sign	n.a.	
	Interior	n.a.	
<b>Night Lid</b>	Perspex		

### Dimensions†

	External	Internal	Packed
<b>Width (mm)</b>	1585	1120	TBC
<b>Depth (mm)</b>	590	475	TBC
<b>Height (mm)</b>	855 to 890 (standard legs)		
	725 (plinth)	545	TBC
	820 to 840 (castors)		
<b>Weight (kg)</b>	158		TBC
<b>Capacity (L)</b>	290		
<b>Footprint (m<sup>2</sup>)</b>	0.94		

### Dimensional Tolerances

† Allow for dimensional tolerances when installing the cabinet(s).

Linear dimensions	Single cabinet		Multiple cabinets	
			At each joint	At each end wall
Less than 1 metre	±5 mm		±5 mm	+15 mm
More than 1 metre	-5 mm to +10 mm		-5 mm to +10 mm	+15 mm

### Performance

<b>Temperature Range (°C)</b>	1 to 4		
<b>Maximum Ambient Temperature (°C)</b>	40		
<b>Sound Power Level (dB(A))</b>	Standard	< 60	

### Ventilation

<b>Top</b>	Not required	<b>Sides</b>	Not required	<b>Rear</b>	Not required
------------	--------------	--------------	--------------	-------------	--------------

### Electrical

<b>Supply</b>	220-240 volts a.c., 50 Hz, single phase supply		
<b>Cord</b>	1.9 m power cord with 3-pin, 10 amp plug		
<b>Current Draw (A)</b>	2.6		

### Remote Services

<b>Location</b>	Rear or base			
<b>Drain Size</b>	OD 19 mm			
<b>Pipe Connection</b>	Liquid line	OD 6.35 mm	Suction line	OD 9.52 mm

### Refrigeration

<b>Controller</b>	SCS Connect			
<b>System Type</b>	Remote cartridge			
<b>Cartridge Weight (kg)</b>	16			
<b>Refrigerant/Charge</b>	Thermostatic expansion valve fitted to suit refrigerant (R134a or R404A standard)/Nitrogen holding charge			
<b>Nominal Capacity (W)</b>	n.a.			
<b>Heat Rejection (W)</b>	Average	n.a.	Peak	n.a.
<b>Remote Duty (W)</b>	310			
<b>Defrost Type</b>	Automatic, off-cycle			



GC.2.GSW.r  
on the SKOPE website

