

Counters & Undercounters

TWT-60F-HC

 Worktop Counter Freezer, 2 Solid Swing Doors



Dimensions	
External Width (mm)	1534
External Depth (mm)	766
External Height (mm)	1004
Exclusions	Depth does not include 26 mm for rear bumpers.
Net Volume (Litres)	375
Gross Volume (Litres)	439
Supplied Shelves	4
Shelf Size (L x D mm)	Two 700 x 546 + Two 700 x 349
Internal Net Height (mm)	630
Unpackaged Weight (kg)	160
Packaged Weight (kg)	171
Packaged Dimensions (W x D x H mm)	1601 x 832 x 1270
Supplied with	Heavy duty lock-in-place ø 127 mm castors (158 mm height)

Build	
Door Description	2 Solid Swing Doors
Exterior Construction	Stainless steel front & countertop, aluminium sides & rear
Interior Construction	Clear coated aluminium, stainless steel base
Air Intake Position	Front
Ventilation Position	Front
Clearance Required	Zero back and sides
Cord Length (Meters)	2.13
Standard w/ Locks	Standard

Technical	
Temperature Range	-23°C
Refrigerant	R290
Voltage/Frequency/Phase	220-240V/50Hz/1
Amps	2.5
Watts	575
Climate Class	5
Operating Statement	Heavy Duty: This appliance is intended for use in ambient temperatures up to 40°C.
Test Standard	EN 16825
EEC	C
Energy Efficiency Index	49.3
Defrost Type	Auto
Energy Consumption (kWh/24h)	6.17
Energy Consumption (kWh/Annum)	2253



Specifications subject to change without notice.
Chart dimensions rounded up to the next whole millimeter (inches rounded up to the 1/8")

UK & Ireland
EMEA
Australia

0800 783 2049
[+41 61 563 07 05](tel:+61615630705)
[+61 2 9619 9999](tel:+61296199999)

TFIUK@truemfg.com
TrueCHCustomerService@truemfg.com
TrueRefAus@truemfg.com



TWT-60F-HC

 Worktop Counter Freezer, 2 Solid Swing Doors

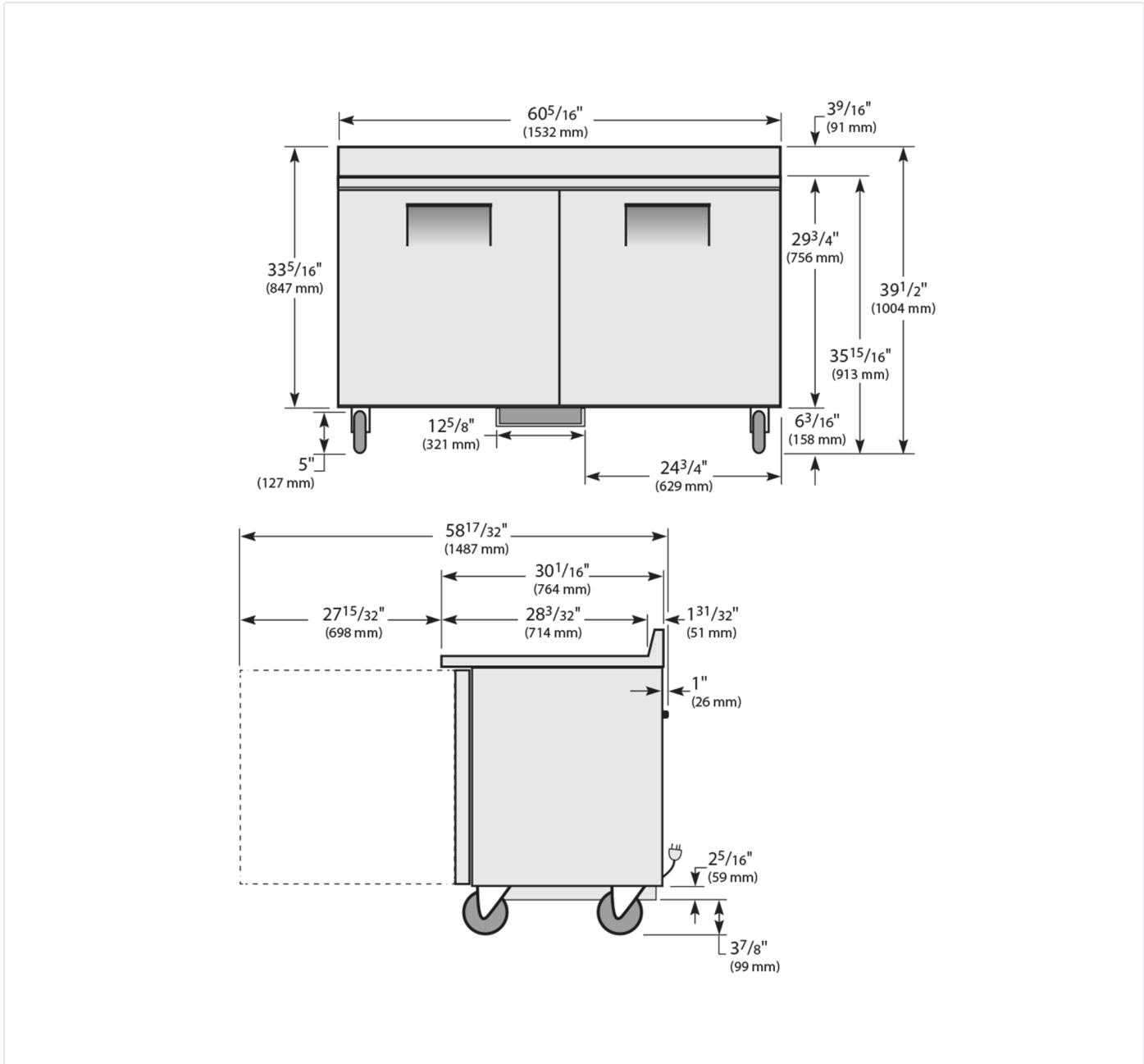

Specifications subject to change without notice.
Chart dimensions rounded up to the next whole millimeter (inches rounded up to the 1/8")

UK & Ireland
EMEA
Australia

0800 783 2049
+41 61 563 07 05
+61 2 9619 9999

TFIUK@truemfg.com
TrueCHCustomerService@truemfg.com
TrueRefAus@truemfg.com

