

TWT-48D-2-HC



Dimensions	
External Width (mm)	1229
External Depth (mm)	766
External Height (mm)	1004
Net Volume (Litres)	166
Gross Volume (Litres)	340
Supplied Shelves	2
Internal Net Height (mm)	630
Per Drawer Capacity (max depth mm)	1x 305 mm x 458 mm pan (150)
Unpackaged Weight (kg)	107
Packaged Weight (kg)	118
Packaged Dimensions (W x D x H mm)	1296 x 839 x 1207

Build	
Drawer Count	2
Cord Length (Meters)	2.13

Technical	
Temperature Range	0.5 : 3.3°C
Refrigerant	R290
Voltage/Frequency/Phase	220-240V/50-60Hz/1
Amps	1
Watts	230
Climate Class	5
Test Standard	EN 16825
EEC	B
Energy Efficiency Index	27
Defrost Type	Auto
Energy Consumption (kWh/24h)	1.64
Energy Consumption (kWh/Annum)	602



Specifications subject to change without notice.
 Chart dimensions rounded up to the next whole millimeter (inches rounded up to the 1/8")

UK & Ireland
 EMEA
 Australia

0800 783 2049
 +41 61 563 07 05
 +61 2 9619 9999

TFIUK@truemfg.com
 TrueCHCustomerService@truemfg.com
 TrueRefAus@truemfg.com



TWT-48D-2-HC

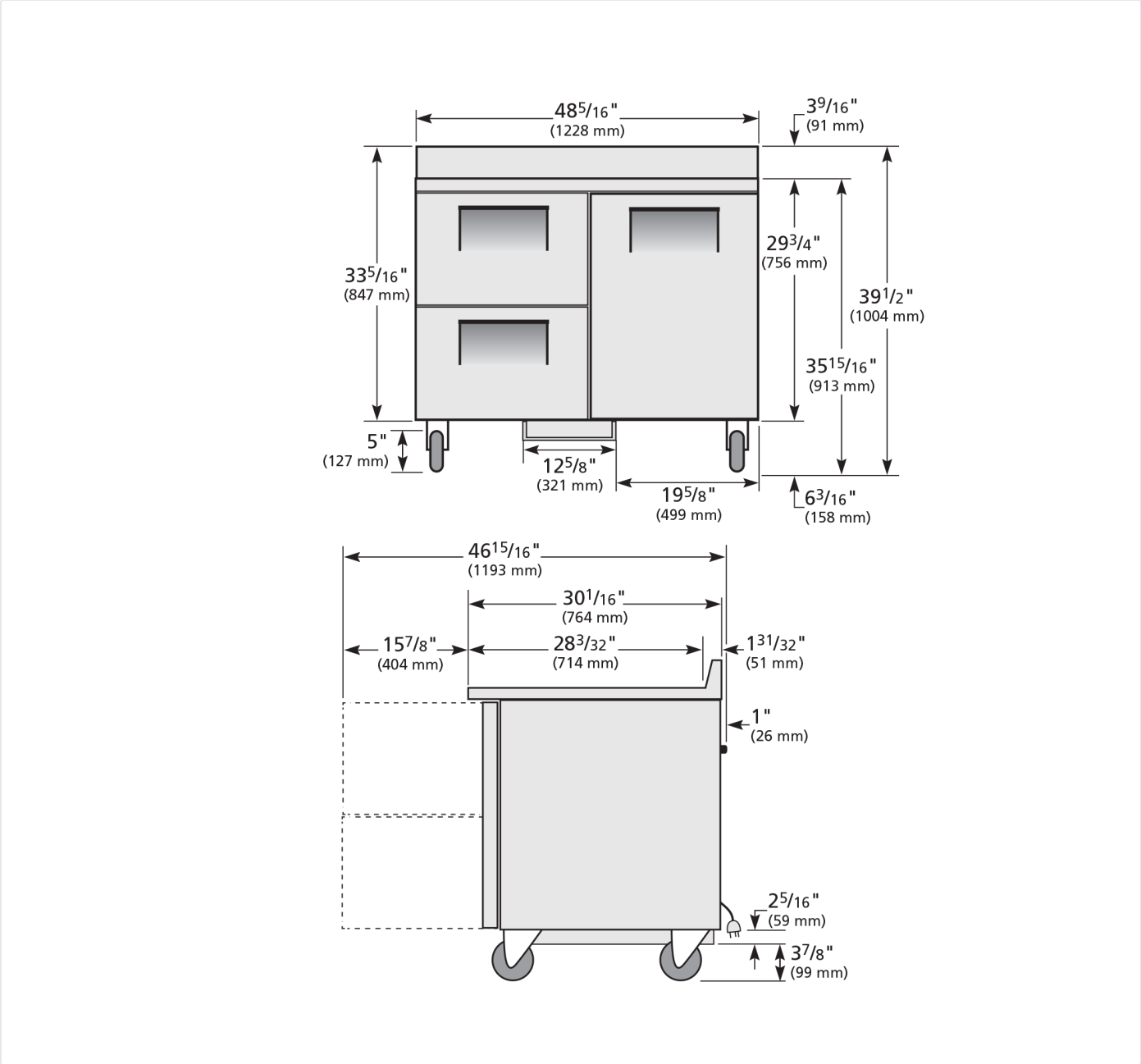

Specifications subject to change without notice.
Chart dimensions rounded up to the next whole millimeter (inches rounded up to the 1/8")

UK & Ireland
EMEA
Australia

0800 783 2049
+41 61 563 07 05
+61 2 9619 9999

TFIUK@truemfg.com
TrueCHCustomerService@truemfg.com
TrueRefAus@truemfg.com

