

Counters & Undercounters

# TWT-27F-HC

 Worktop Counter Freezer, 1 Solid Swing Door



Dimensions	
External Width (mm)	702
External Depth (mm)	766
External Height (mm)	1004
Exclusions	Depth does not include 26 mm for rear bumpers.
Net Volume (Litres)	143
Gross Volume (Litres)	184
Supplied Shelves	2
Shelf Size (L x D mm)	One 590 x 488 + One 590 x 349
Internal Net Height (mm)	630
Unpackaged Weight (kg)	85
Packaged Weight (kg)	96
Packaged Dimensions (W x D x H mm)	769 x 839 x 1207
Supplied with	Heavy duty lock-in-place ø 127 mm castors (158 mm height)

Build	
Door Description	1 Solid Swing Door
Door Opening	Right (standard) or Left Field Reversible
Exterior Construction	Stainless steel front & countertop, aluminium sides & rear
Interior Construction	Clear coated aluminium, stainless steel base
Air Intake Position	Front
Ventilation Position	Front
Clearance Required	Zero back and sides
Cord Length (Meters)	2.13
Standard w/ Locks	Standard

Technical	
Temperature Range	-23°C
Refrigerant	R290
Voltage/Frequency/Phase	220-240V/50-60Hz/1
Amps	1.3
Watts	299
Climate Class	5
Operating Statement	Heavy Duty: This appliance is intended for use in ambient temperatures up to 40°C.
Test Standard	EN 16825
EEC	C
Energy Efficiency Index	45.8
Defrost Type	Auto
Energy Consumption (kWh/24h)	4.03
Energy Consumption (kWh/Annum)	1472



Specifications subject to change without notice.  
Chart dimensions rounded up to the next whole millimeter (inches rounded up to the 1/8")

UK & Ireland  
EMEA  
Australia

0800 783 2049  
[+41 61 563 07 05](tel:+61615630705)  
[+61 2 9619 9999](tel:+61296199999)

[TFIUK@truemfg.com](mailto:TFIUK@truemfg.com)  
[TrueCHCustomerService@truemfg.com](mailto:TrueCHCustomerService@truemfg.com)  
[TrueRefAus@truemfg.com](mailto:TrueRefAus@truemfg.com)



# TWT-27F-HC

 Worktop Counter Freezer, 1 Solid Swing Door

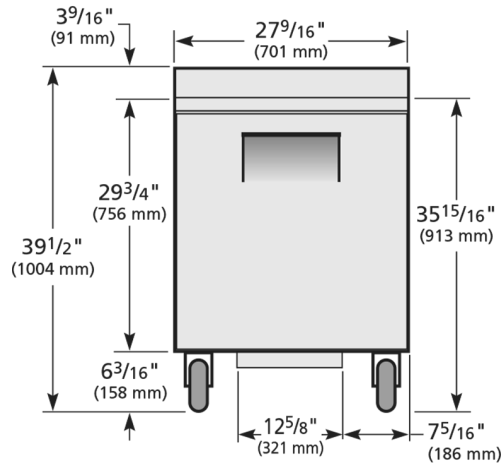

ELEVATION

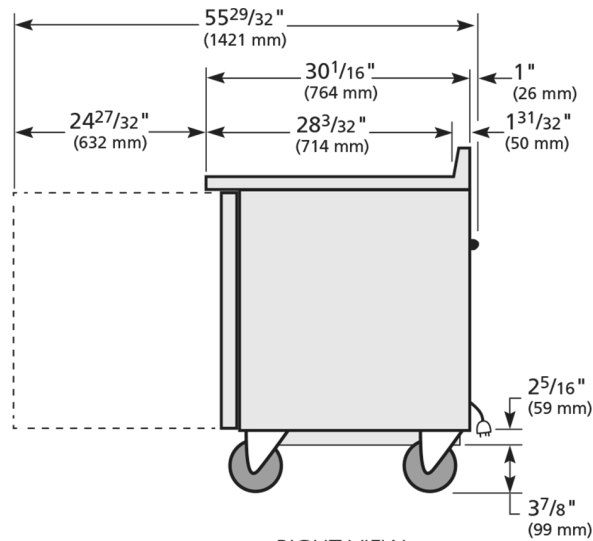

RIGHT VIEW



Specifications subject to change without notice.  
Chart dimensions rounded up to the next whole millimeter (inches rounded up to the 1/8")

UK & Ireland  
EMEA  
Australia

0800 783 2049  
[+41 61 563 07 05](tel:+41615630705)  
[+61 2 9619 9999](tel:+61296199999)

[TFIUK@truemfg.com](mailto:TFIUK@truemfg.com)  
[TrueCHCustomerService@truemfg.com](mailto:TrueCHCustomerService@truemfg.com)  
[TrueRefAus@truemfg.com](mailto:TrueRefAus@truemfg.com)

