

# TUC-48D-4-HC



Dimensions	
External Width (mm)	1229
External Depth (mm)	766
External Height (mm)	839
Net Volume (Litres)	53
Gross Volume (Litres)	340
Per Drawer Capacity (max depth mm)	1x 305 mm x 458 mm pan (150)
Unpackaged Weight (kg)	107
Packaged Weight (kg)	118
Packaged Dimensions (W x D x H mm)	1296 x 839 x 1207

Build	
Drawer Count	4
Cord Length (Meters)	2.13

Technical	
Temperature Range	0.5 : 3.3°C
Refrigerant	R290
Voltage/Frequency/Phase	220-240V/50-60Hz/1
Amps	1
Watts	230
Climate Class	5
Test Standard	EN 16825
EEC	C
Energy Efficiency Index	44
Defrost Type	Auto
Energy Consumption (kWh/24h)	2.34
Energy Consumption (kWh/Annum)	855



Specifications subject to change without notice.  
Chart dimensions rounded up to the next whole millimeter (inches rounded up to the 1/8")

UK & Ireland  
EMEA  
Australia

[0800 783 2049](tel:08007832049)  
[+41 61 563 07 05](tel:+41615630705)  
[+61 2 9619 9999](tel:+61296199999)

[TFIUK@truemfg.com](mailto:TFIUK@truemfg.com)  
[TrueCHCustomerService@truemfg.com](mailto:TrueCHCustomerService@truemfg.com)  
[TrueRefAus@truemfg.com](mailto:TrueRefAus@truemfg.com)



# TUC-48D-4-HC

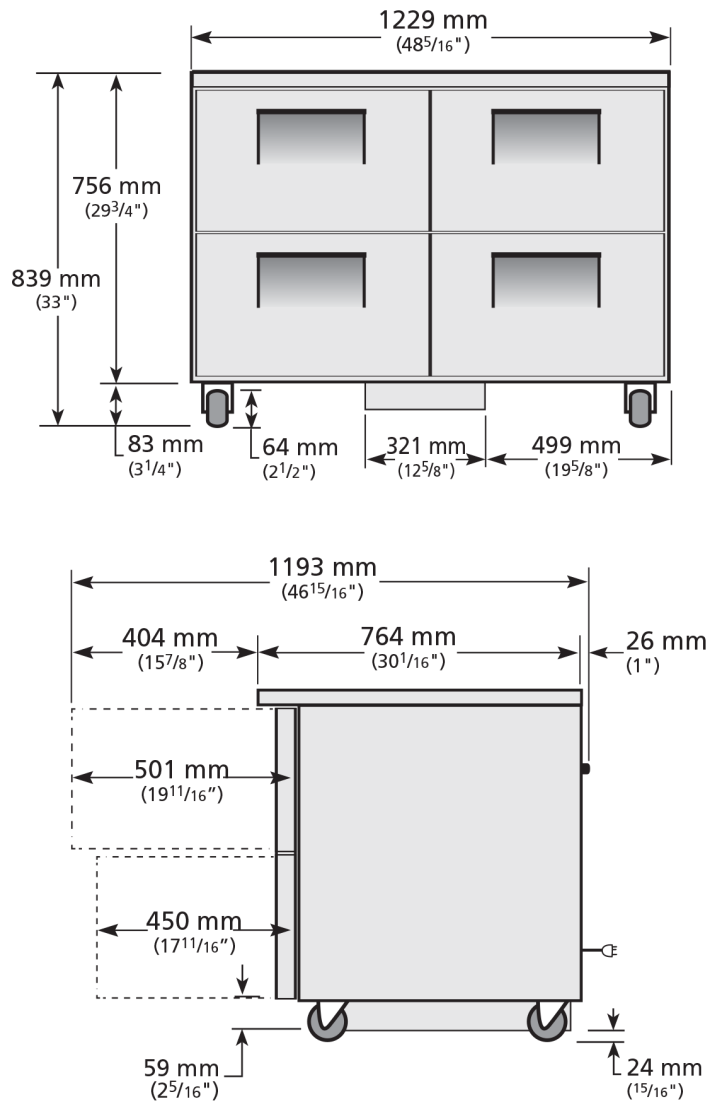

Specifications subject to change without notice.  
Chart dimensions rounded to the next whole millimeter (inches rounded up to the 1/8")

UK & Ireland  
EMEA  
Australia

0800 783 2049  
+41 61 563 07 05  
+61 2 9619 9999

[TFIUK@truemfg.com](mailto:TFIUK@truemfg.com)  
[TrueCHCustomerService@truemfg.com](mailto:TrueCHCustomerService@truemfg.com)  
[TrueRefAus@truemfg.com](mailto:TrueRefAus@truemfg.com)

