

Bar Refrigeration

TDR52-RISZ1-L-B-SS-2

 Keg Chiller / Dispenser, Black Ext, 2 Solid Swing Doors



Dimensions	
External Width (mm)	1321
External Depth (mm)	631
External Height (mm)	881
Exclusions	Depth does not include 35 mm for door handles. Height does not include 7 mm for leg levelers or 400 mm for draft tower.
Gross Volume (Litres)	550
Unpackaged Weight (kg)	85
Packaged Weight (kg)	96
Packaged Dimensions (W x D x H mm)	1486 x 724 x 1067
Internal Capacity for Keg (L x D x H mm)	924 x 477 x 783
Supplied with	Levelling Screws. Optional castors sold seperately.

Build	
Door Description	2 Solid Swing Doors
Exterior Construction	Black powder coated steel front. Matching black coated Aluminium sides & rear. Stainless steel countertop.
Interior Construction	Stainless Steel
Air Intake Position	Front
Ventilation Position	Front
Clearance Required	Zero back and sides
Cord Length (Meters)	3.04
Internal Lighting	LED
Standard w/ Locks	Standard

Technical	
Temperature Range	0.5 : 3.3°C
Refrigerant	R290
Voltage/Frequency/Phase	220-240V/50-60Hz/1
Amps	1.3
Watts	299
Defrost Type	Auto



Specifications subject to change without notice.
Chart dimensions rounded up to the next whole millimeter (inches rounded up to the 1/8")

UK & Ireland
EMEA
Australia

[0800 783 2049](tel:08007832049)
[+41 61 563 07 05](tel:+41615630705)
[+61 2 9619 9999](tel:+61296199999)

TFIUK@truemfg.com
TrueCHCustomerService@truemfg.com
TrueRefAus@truemfg.com



TDR52-RISZ1-L-B-SS-2

 Keg Chiller / Dispenser, Black Ext, 2 Solid Swing Doors

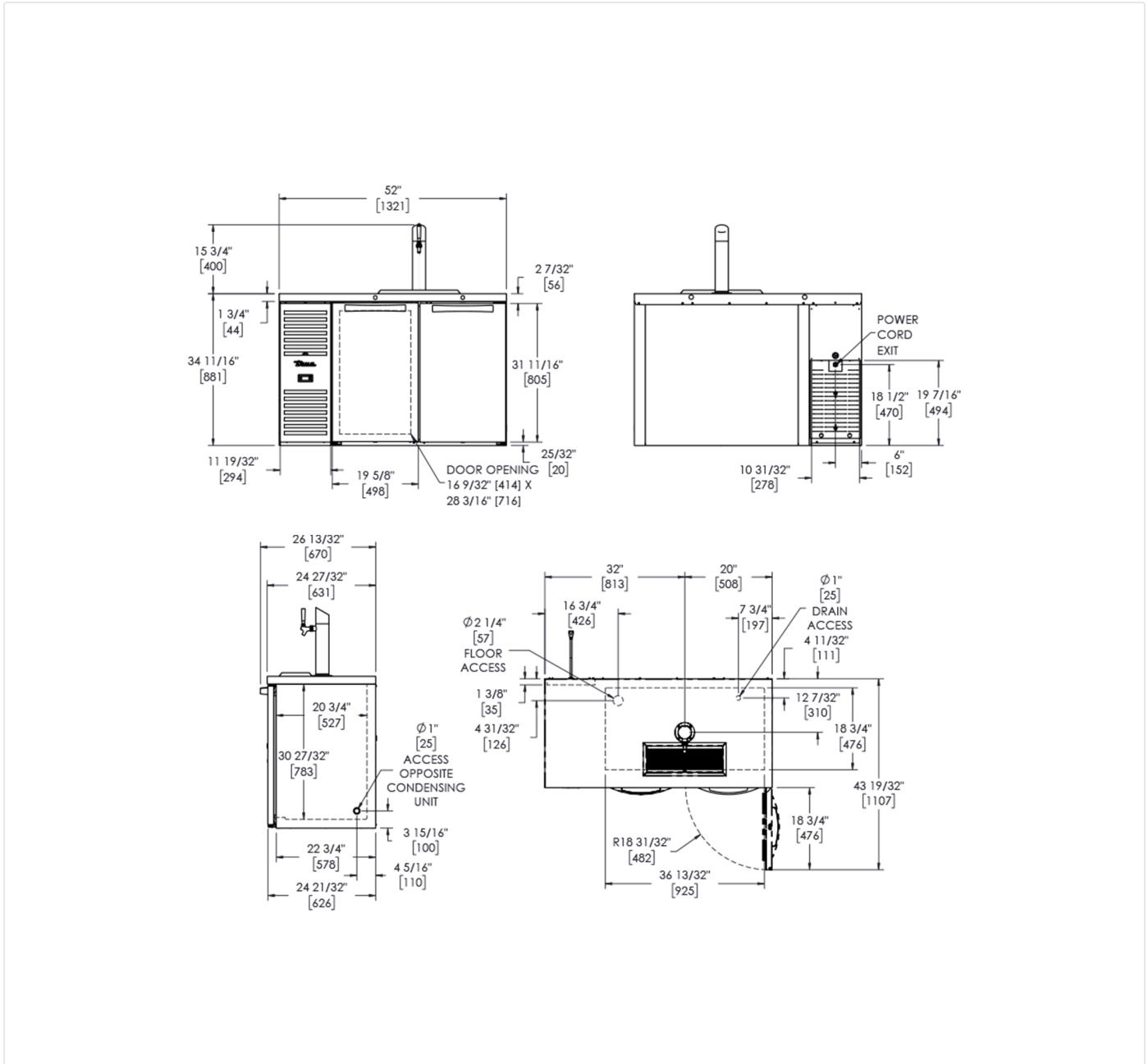

Specifications subject to change without notice.
 Chart dimensions rounded to the next whole millimeter (inches rounded up to the 1/8")

UK & Ireland
 EMEA
 Australia

0800 783 2049
 +41 61 563 07 05
 +61 2 9619 9999

TFIUK@truemfg.com
 TrueCHCustomerService@truemfg.com
 TrueRefAus@truemfg.com

